



Harrison V460/V550

V460 18" Swing Vari-speed Lathe
V550 21" Swing Vari-speed Lathe



ORIGINAL INSTRUCTIONS AND SPARE PARTS MANUAL

MACHINE MANUAL PART # 2 OF 2

V460 18" Swing & V550 21" Swing Harrison Vari-speed Center Lathes

The Ultimate Turning Machines

The V460's and V550's feature packed design offers the advantage of infinitely variable spindle speeds whilst maintaining equal capabilities for high rates of metal removal or fine precision finishing. On production, maintenance work or in the toolroom the V460 or V550 represents an outstanding investment with operators immediately responding to its easy positive and comfortable controls.

Features

All Harrison V Machines Feature:

- Cast iron triangular webbed bed for optimum rigidity and swarf clearance
- Infinitely variable spindle speeds with digital display
- Camlock spindle nose for fast chuck changeover
- Leadscrew reversing box
- Standard constant surface speed (CSS) cutting with DRO Comprehensive range of imperial and metric screw thread cutting

Specifications

		V460	V550
Centers	Height	230mm (9")	280mm (11")
	Admit Between	1500mm (60")	2000/3000mm (80/120")
Swing	Over Bed	460mm (18")	554mm (21-7/8")
	Over Cross Slide	270mm (10-5/8")	370mm (14-1/2")
	In Gap Diameter	730mm (28-3/4")	830mm (32-3/4")
	Length	216mm (8-1/2")	216mm (8-1/2")
Spindle	Bore	76mm (3")	90mm (4.1")
	Nose	D1-8 Camlock	D1-11 Camlock
	Morse Taper in Nose	5 MT	5 MT
Speeds	Number	3 infinitely variable	3 infinitely variable
	Range	20 to 2000rpm	18 to 1800rpm
Motor		11kW	11kW
Leadscrew	Diameter	38mm (1-1/2")	38mm (1-1/2")
	Thread	6mm pitch or 4 TPI	6mm pitch or 4 TPI
Threads	Metric Pitches	78 from 0.2 to 14mm	78 from 0.2 to 14mm
	Imperial Pitches	79 from 2 to 84 TPI	79 from 2 to 84 TPI
	Module Pitches	47 from 0.2 to 3.5 MOD	47 from 0.2 to 3.5 MOD
	Diametral Pitches	47 from 8 to 72 DP	47 from 8 to 72 DP
Feeds	Metric	38 from .04 to .84mm/rev	38 from .04 to .84mm/rev
	Imperial	38 from .0016 to .110in/rev	38 from .0016 to .110in/rev
Cross Slide	Width	203mm (8")	203mm (8")
	Travel	300mm (11-7/8")	300mm (11-7/8")
Top Slide	Width	133mm (5-1/4")	133mm (5-1/4")
	Travel	150mm (6")	175mm (6-7/8")
Tailstock	Quill Diameter	95mm (3-1/4")	95mm (3-1/4")
	Travel	145mm (5-11/16")	178mm (7")
	Morse Taper	6 MT	6 MT
Weight		2615kg (5753lbs)	2850/3610kg (6270/7942lbs)
Dimensions	L x W x H	3.25x1.70x2.05m (128x67x81")	3.75x1.70x2.10m (147x67x81")
			4.75x1.70x2.10m (187x67x81")

RELAY BOARD SCHEMATIC DIAGRAM

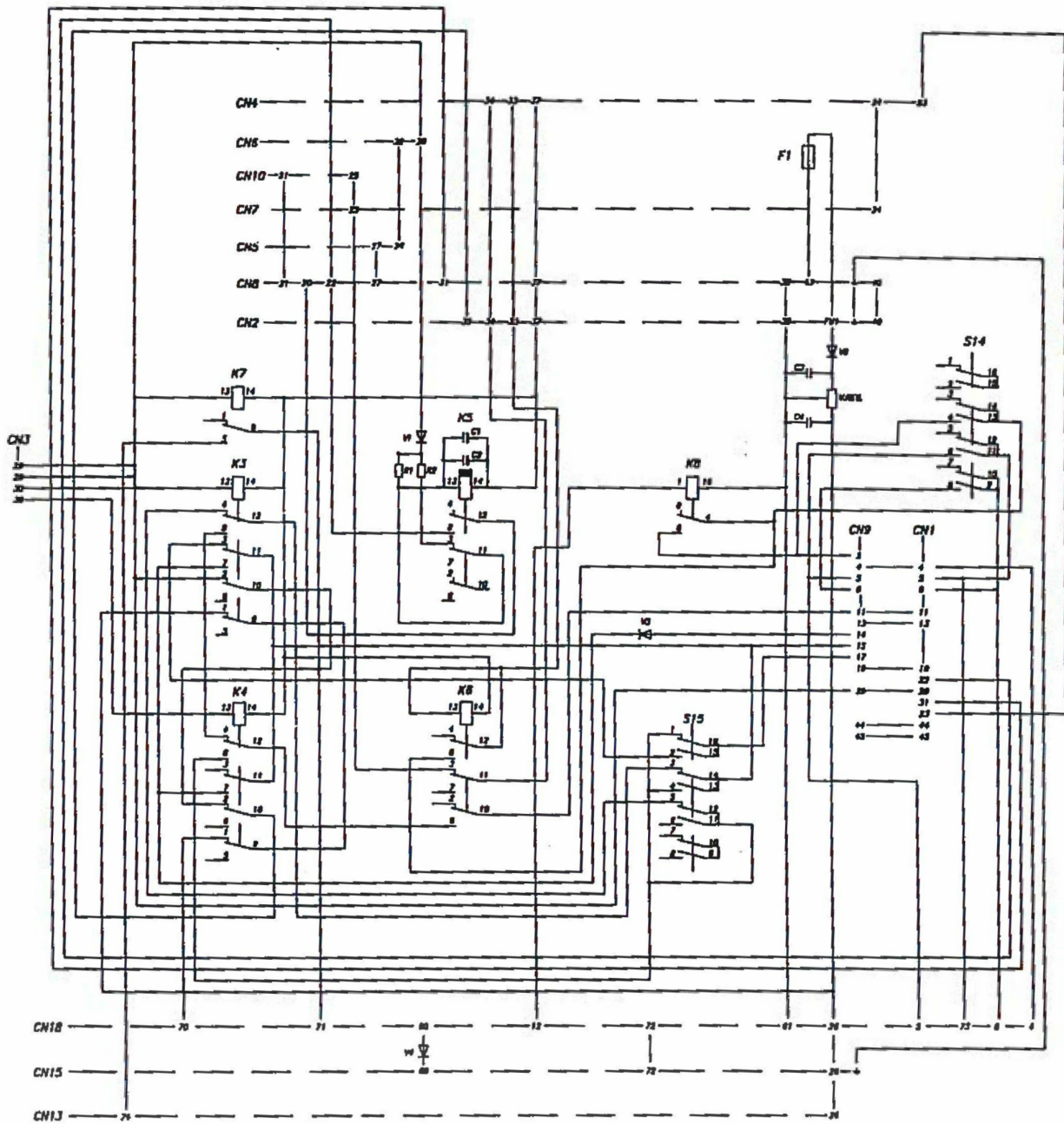



RELAY BOARD (PARTS LIST)

EP 767

Item No.	Description	Part No.
	FUSE CARTRIDGE 20x5mm 500mA FUSE HOLDER 20x5mm (FU1) RESISTOR 1k.250mW. 10% (R1) 231-132 WAGO SOCKET 2-POLE (CN5/6/7/10/13) 231-134 WAGO SOCKET 4-POLE (CN3/15) 231-138 WAGO SOCKET 8-POLE (CN2/4) 231-140 WAGO SOCKET 10-POLE (CN8) 231-142 WAGO SOCKET 12-POLE (CN1/18) 231-144 WAGO SOCKET 14-POLE (CN9) MY4-02 SERIES OMRON RELAY 4-POLE C/O 11 0V (K3,4,6) RP410615 SCHRACK RELAY 1-POLE C/O 110V (K7) MY4-02 SERIES OMRON RELAY 4-POLE C/O 24VDC (K5) 'RS' RELAY 2-POLE C/O 24VDC STOCK No. 351-847 (K8) RESISTOR 120R. 250mW. 10% (R2) DIODE 1N4004 (V1/2/3) CAPACITOR. ELECTROLYTIC (C1) 220µF.40V CAPACITOR. ELECTROLYTIC (C2) 330µF.40V CAPACITOR 470µF 63V (C3) CAPACITOR 100nF (C4) DIODE. 1N4148(V4) VOLTAGE REGULATOR 24VDC.(V.REG) 4-POLE 2-WAY SLIDE SWITCH(S14/15) (DIL. PACKAGE)	
CN1	OPERATOR'S PANEL	
CN2	OPERATOR'S PANEL	
CN3	THIRD SHAFT SWITCH	
CN4	AUXILIARY OPERATOR'S PANEL	
CN5	END GUARD	
CN6	CHUCKGUARD	
CN7	KICKSTOP	
CN8	MAGNETIC'S PANEL	
CN9	SPINDLE DRIVE UNIT	
CN10	BRAKE OVERLOAD UNIT	
CN13	IN GEAR POSITION	
CN15	SPEED DISPLAY Y/POT.SWITCH	
CN18	DRO/CSS UNIT	

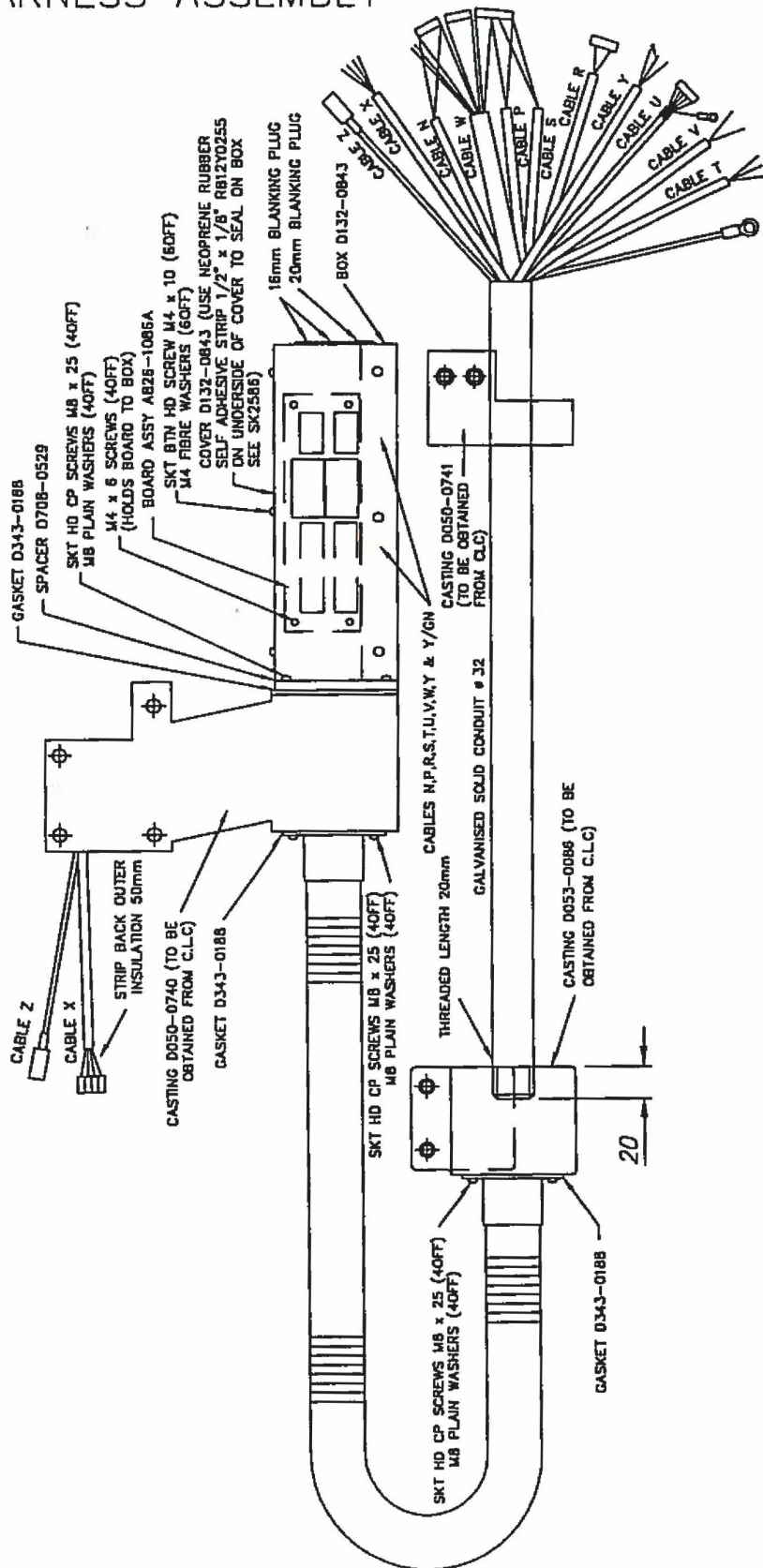
APRON HARNESS ASSEMBLY



CABLE T 3 CORE 0.5mm² CABLE			
WIRE No.		CORE COLOUR	P.C.B.
91		BLUE	91
92		BROWN	92
		YELLOW/GREEN	

CABLE U 12-CORE 16/0.2mm SCREENED			
CN18 12-WAY PLUG	WIRE No.	CORE COLOUR	P.C.B.
1	70 (R.H.S)	WHITE	70
2	71	MAUVE	71
3	60	TURQUOISE	60
4	12	PINK	12
5	72	BLACK	72
6	61	GREY	61
7	26	ORANGE	26
8	5	YELLOW	5
9	73	GREEN	73
10	6	RED	6
11	4	BLUE	4
SN	NC (LHS)	SCREEN	SN

CABLE V 3 CORE 0.5mm² CABLE			
WIRE No.		CORE COLOUR	P.C.B.
81		BLUE	81
82		BROWN	82
SPARE		YELLOW/GREEN	SPARE



CABLE W 12-CORE 16/0.2mm NON-SCREENED			
CN1 12-WAY PLUG	WIRE No.	CORE COLOUR	P.C.B.
7	22	RED	22
8	29	BLUE	29
9	31 (LHS)	YELLOW	31
10	23	TURQUOISE	23
SPARE	SPARE	ORANGE	SPARE



CABLE W 12-CORE 16/0.2mm NON-SCREENED			
CN2 8-WAY PLUG	WIRE No.	CORE COLOUR	P.C.B.
1	32 (RHS)	WHITE	32
3	33	BLACK	33
4	37	VIOLET	37
8	40	PINK	40
SPARE	SPARE	GREY	SPARE



CABLE W 12-CORE 16/0.2mm NON-SCREENED			
CN3 4-WAY PLUG	WIRE No.	CORE COLOUR	P.C.B.
1	36	BROWN	36
3	30	GREEN	30



CABLE S 4-CORE 7/0.2mm SCREENED			
CN1 12-WAY PLUG	WIRE No.	CORE COLOUR	P.C.B.
4	11	BLACK	11
5	13	RED	13
6	19	WHITE	19
SPARE	SPARE	GREEN	SPARE
12	45	SCREEN	45

CABLE P 4 - CORE 7/0.2mm SCREENED			
CN1 12-WAY PLUG	WIRE No.	CORE COLOUR	P.C.B.
1	4 (RHS)	BLACK	4
2	5	WHITE	5
3	6	RED	6
SPARE	SPARE	GREEN	SPARE
11	44	SCREEN	44

CABLE N 2 - CORE 7/0.2mm SCREENED			
CN2 8-WAY PLUG	WIRE No.	CORE COLOUR	P.C.B.
5	38	BLACK	38
6	F1	RED	F1
7		SCREEN	

CABLE R 2 - CORE 7/0.2mm SCREENED			
CN15 4-WAY PLUG	WIRE No.	CORE COLOUR	P.C.B.
2	72	BLACK	72
3	26	RED	26
4		SCREEN	

CABLE X 4 - CORE 1.0mm ² CABLE			
WIRE No.	CORE COLOUR	CONNECTOR	COLOUR
U5	BLUE	U5	BLACK
V5	BROWN	V5	BLACK
W5	BLACK	W5	BLACK
	YELLOW/GREEN		GREEN

CABLE Y 3 - CORE 0.5mm ² CABLE		
WIRE No.	CORE COLOUR	P.C.B.
21	BROWN	21
37	BLUE	37
	YELLOW/GREEN	

CABLE Z 4 - CORE 7/0.2mm SCREENED CABLE			
PLUG PIN No.	CORE COLOUR	REF ONLY	PLUG PIN No.
1	RED	46	1
2	BLACK	47	2
3	GREEN	48	3
4	WHITE	49	4

NOTE: SCREEN TO BE CONNECTED TO DIN CONNECTORS

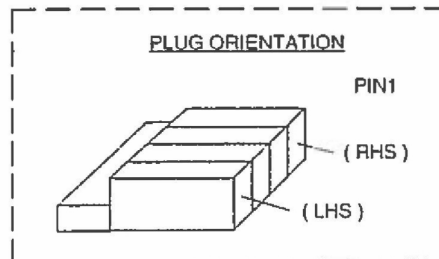

NAMEPLATE ASSEMBLY

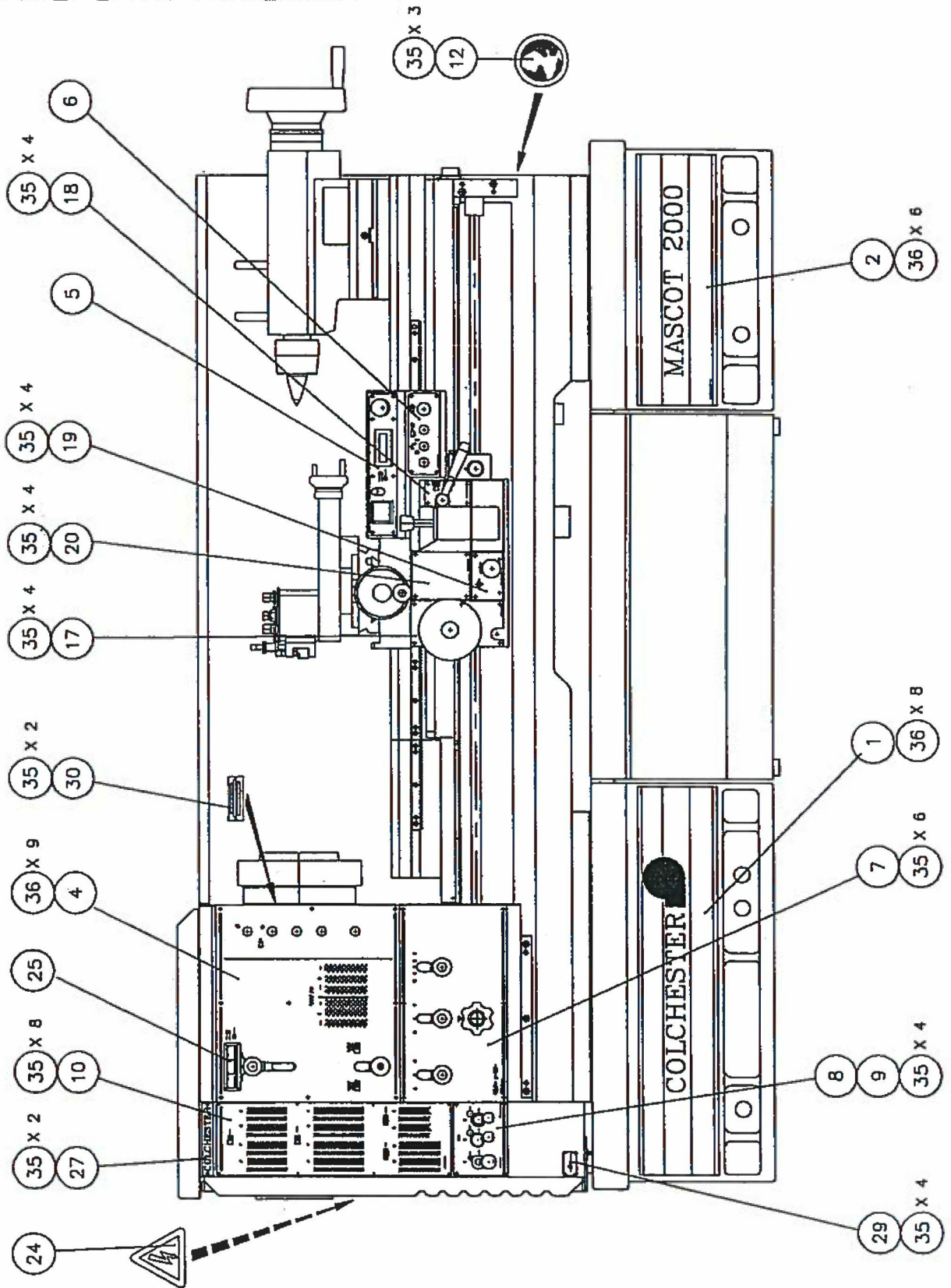

NAMEPLATE ASSEMBLY

A161 - 0606

Item No.	Description	Part No.
1	'COLCHESTER' PLATE	D537 - 1095
2	'MASCOT 2000'	D537 - 1096
4	HEADSTOCK PUSH BUTTON AND REVERSE BOX PLATE	D537 - 1098
5	UPPER APRON CONTROL PLATE	D537 - 1099
6	LOWER APRON CONTROL PLATE	D537 - 1100
7	GEARBOX PLATE	D537 - 1101
8	METRIC CHANGE WHEEL PLATE	D537 - 1102
9	IMPERIAL CHANGE WHEEL PLATE	D537 - 1103
10	THREAD AND FEED PLATE	D537 - 1104
12	'WORLD TURNS ' PLATE	D537 - 0783
17	APRON PLATE	D537 - 1108
18	APRON HALF NUTPLATE	D537 - 1111
19	APRON KNOCK-OFF	D537 - 1112
20	APRON BLANK PLATE	D537 - 1113
24	ELECTRICAL WARNING FLASH	D565Y0406
25	SPEED RANGE PLATE	D537 - 1109
27	SMALL 'COLCHESTER' PLATE	D537 - 1057
28	RED ARROW LABEL	D537 - 1039
29	'600 GROUP' LOGO PLATE	D537 - 1071
30	CHUCK WARNING PLATE	D537 - 1082
35	TAPTITE SCREW M3x5	B123 - 6065
36	HEXAGON SOCKET BUTTON HEAD SCREW M6x10	B163 - 1813

TRIMMINGS ASSEMBLY (1)

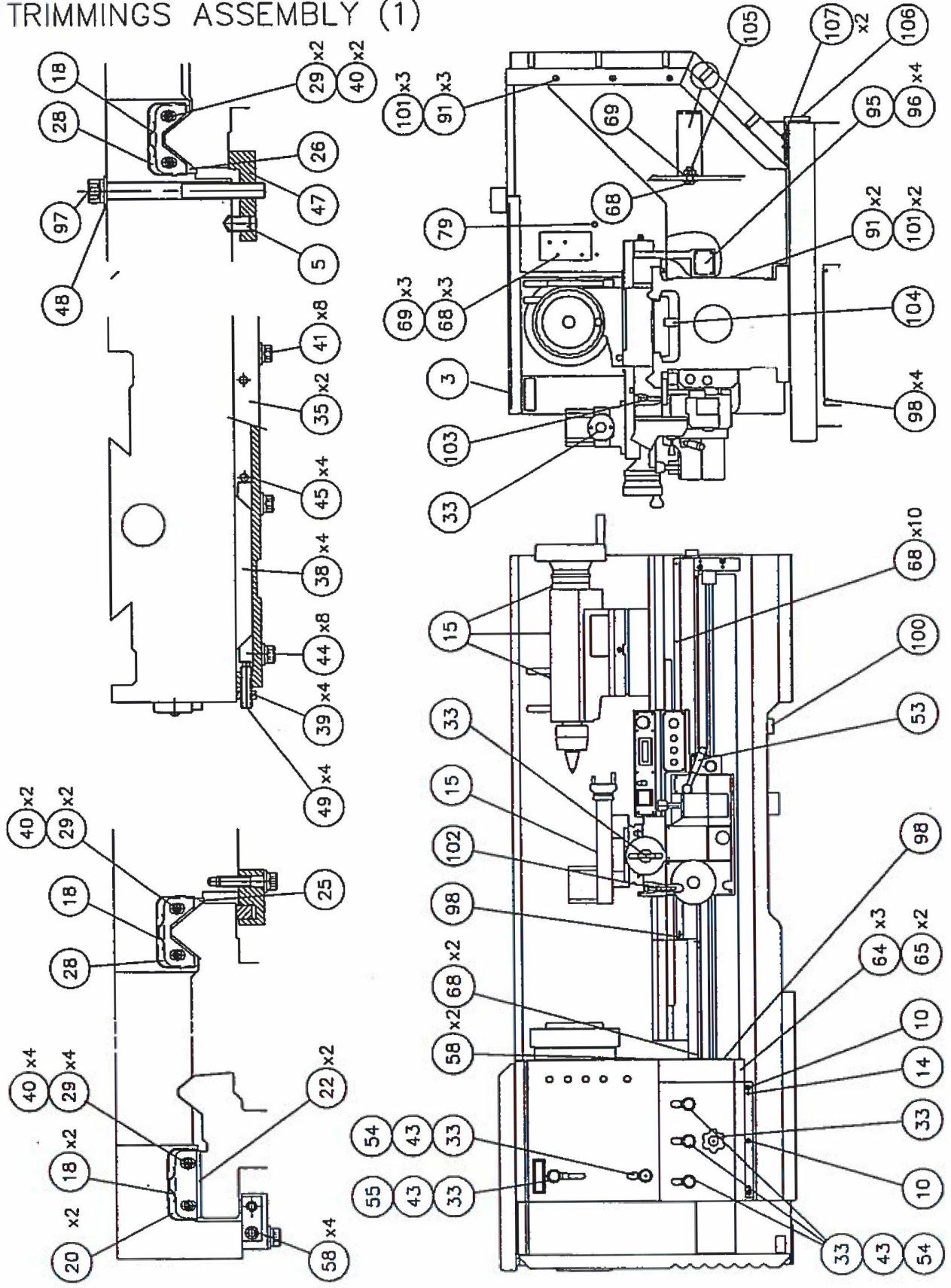

TRIMMINGS ASSEMBLY

A176 - 0610

Item No.	Description	Part No.
1	SETOVER PAD	D557 - 0154
2	SET OVER PIN	D560 - 0297
3	HEADSTOCK MAT	D132 - 0813
4	GEARBOX GASKET	D403H003
5	WEDGÉLOK SET SCREW M12x20	B164 - 0170
6	SPIROL PIN 10x40	B111 - 5160
7	HEXAGON SOCKET CAP HEAD SCREW M10x40	B163 - 0071
9	HEXAGON SOCKET CAP HEAD SCREW M10x50	B163 - 0073
10	HEXAGON SOCKET CAP HEAD SCREW M10x25	B163 - 0068
13	DOWEL PIN 12x36	B111Y7093
14	DOWEL PIN 10x30	B111 - 7057
15	CONCAVE LUBRICATOR 6mm DIA.	B454 - 2004
17	TAILSTOCK VEE SHIELD	D725 - 0027
18	LEAF SPRING	D707 - 0051
19	TAILSTOCK BED VEE WIPER	D937 - 0018
20	SADDLE/TAILSTOCK FLAT WIPER SHIELD	D725 - 0013
21	SPRING	D937 - 0068
22	SADDLE/TAILSTOCK BED FLAT WIPER	D937 - 0010
25	SADDLE BED VEE WIPER (LH)	D937 - 0011
26	SADDLE BED VEE WIPER (RH)	D937 - 0012
28	SADDLE VEE WIPER SHIELD	D725 - 0014
29	WIPER SPACER	D708 - 0087
33	BLUE PLASTIC DISC	B224 - 2143
35	SADDLE STRIP MOUNT	D715 - 0187 D 345 - 0090
38	SADDLE STRIP	D715 - 0197
39	LOCKING PLATE	D565 - 1078
40	HEXAGON SOCKET BUTTON HEAD SCREW M4x16	B163 - 1806
41	HEXAGON SOCKET CAP HEAD SCREW M8x35	B163 - 0056
43	SLOTTED PAN HEAD SCREW M8x16	B165 - 0143
44	STRIP ADJUSTER	D715 - 0198
45	SPIROL PIN 6x22	B111 - 5110
47	SADDLE CLAMP	D715 - 0172
49	HEXAGON SOCKET SETSCREW M8x35	B163 - 1757
53	APRON HANDLE	D382 - 0078
54	GEARBOX HANDLE	D382 - 0137
55	RANGE CHANGE HANDLE	D382 - 0146
58	HEXAGON SOCKET BUTTON HEAD SCREW M6x16	B163 - 1815

TRIMMINGS ASSEMBLY (2)

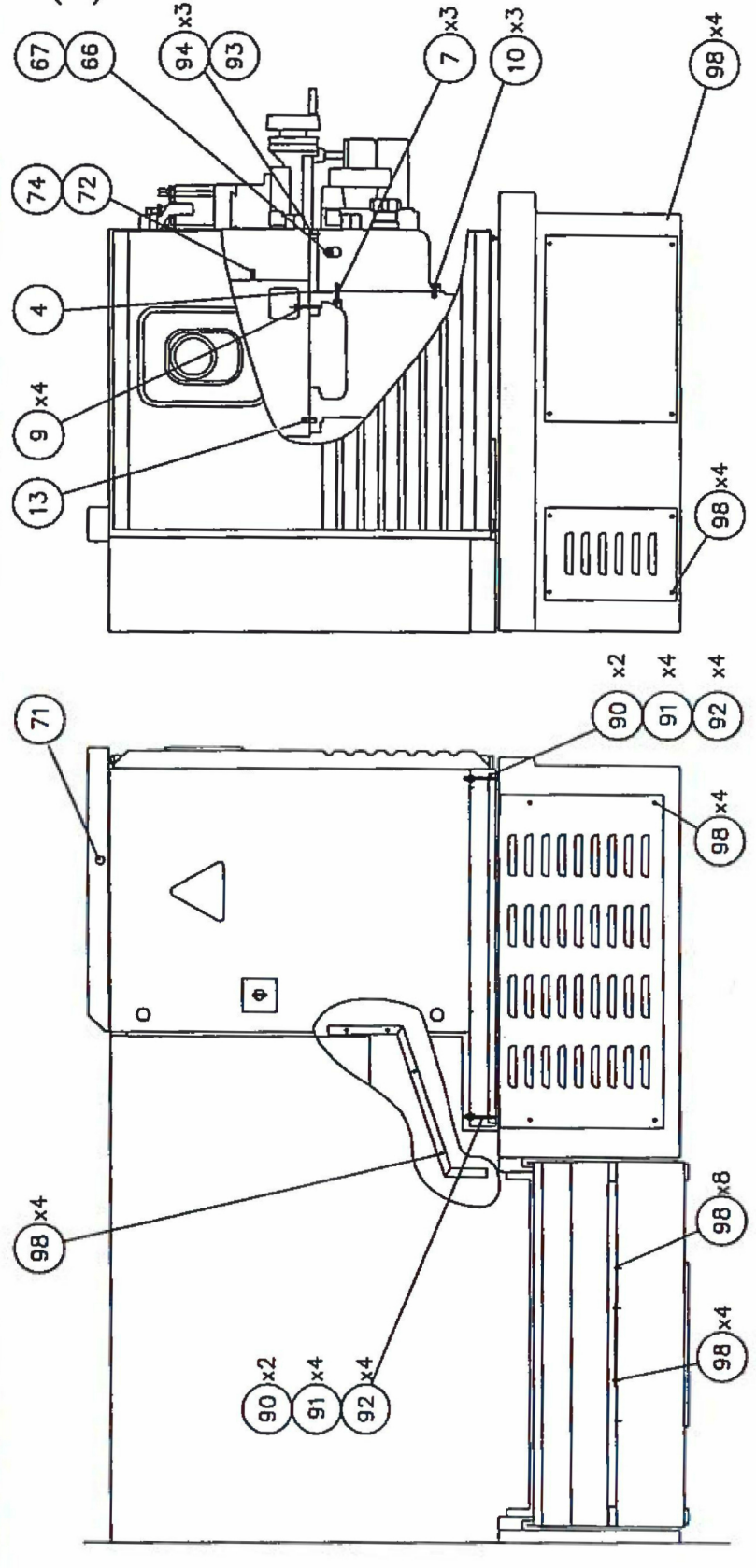
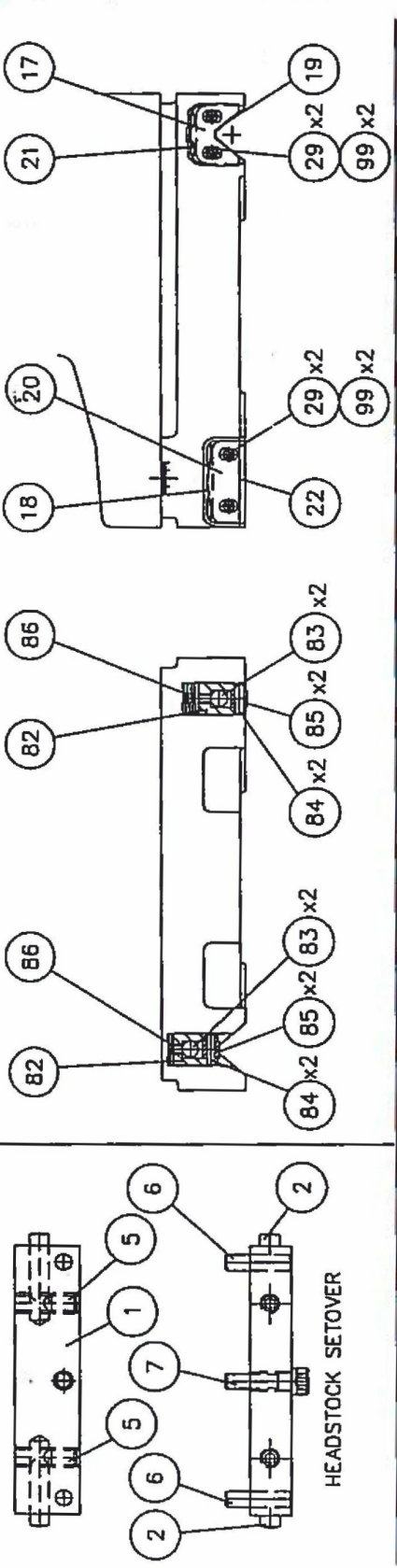

TRIMMINGS ASSEMBLY

A176 - 0610

Item No.	Description	Part No.
64	GEAR BOX EXTENSION BRACKET	D050 - 0744
65	HEXAGON SOCKET CAP HEAD SCREW M8x30	B163 - 0055
66	3/4" BSP M/F 45° BEND	B424 - 2255
67	3/4" BSP PLUG	B424 - 2815
68	HEXAGON SOCKET BUTTON HEAD SCREW M6x12	B163 - 1900
69	WASHER M6	B117 - 0048
71	PLUG 16mm	B715 - 1077
72	TUBING CLIP	B233 - 1103
74	HEXAGON SOCKET BUTTON HEAD SCREW M4x10	B163 - 1804
79	BLANKING PLUG 25mm	B224 - 2240
82	ROLLER HOUSING	D388 - 0143
83	DOWEL PIN	D560 - 0248
84	ROLLER PIN	D560 - 0178
85	NEEDLE BEARING NK 5/10	B337 - 2001
86	ANDERTON SPRING DISC	B365 - 6040
90	ELECTRICAL CABINET SUPPORT STUD	D711 - 0203
91	WASHER M8	B117 - 0034
92	LOCK NUT M8	B147 - 9170
93	GEARBOX FILL BAR	D041 - 0248
94	HEXAGON SOCKET CAP HEAD SCREW M5x20	B163Y0028
95	BLANKING PLATE	D565 - 1087
96	HEXAGON SOCKET BUTTON HEAD SCREW M8x16	B163 - 1821
97	SADDLE LOCKING BOLT	D697 - 0391
98	HEXAGON SOCKET BUTTON HEAD SCREW M6x10	B163 - 1813
99	HEXAGON SOCKET DOME HEAD SCREW M5x16	B163 - 1809
100	HEXAGON SOCKET CAP HEAD SCREW M6X16	B163 - 0037
101	PLATED BUTTON HEAD SCREW M8x20	B163 - 1905
102	HEXAGON SOCKET CAP HEAD SCREW M10x80	B163 Y0079
103	HEXAGON SOCKET CAP HEAD SCREW M10x100	B163 Y0081
104	STOP PIN	D560 - 0307
105	NUT M6	B147 - 9152
106	HEXAGON SOCKET SET SCREW M10x25	B163 - 1588
107	HEXAGON HEAD SOCKET SCREW M12	B166 - 0218

SHEET METAL PACK (1)

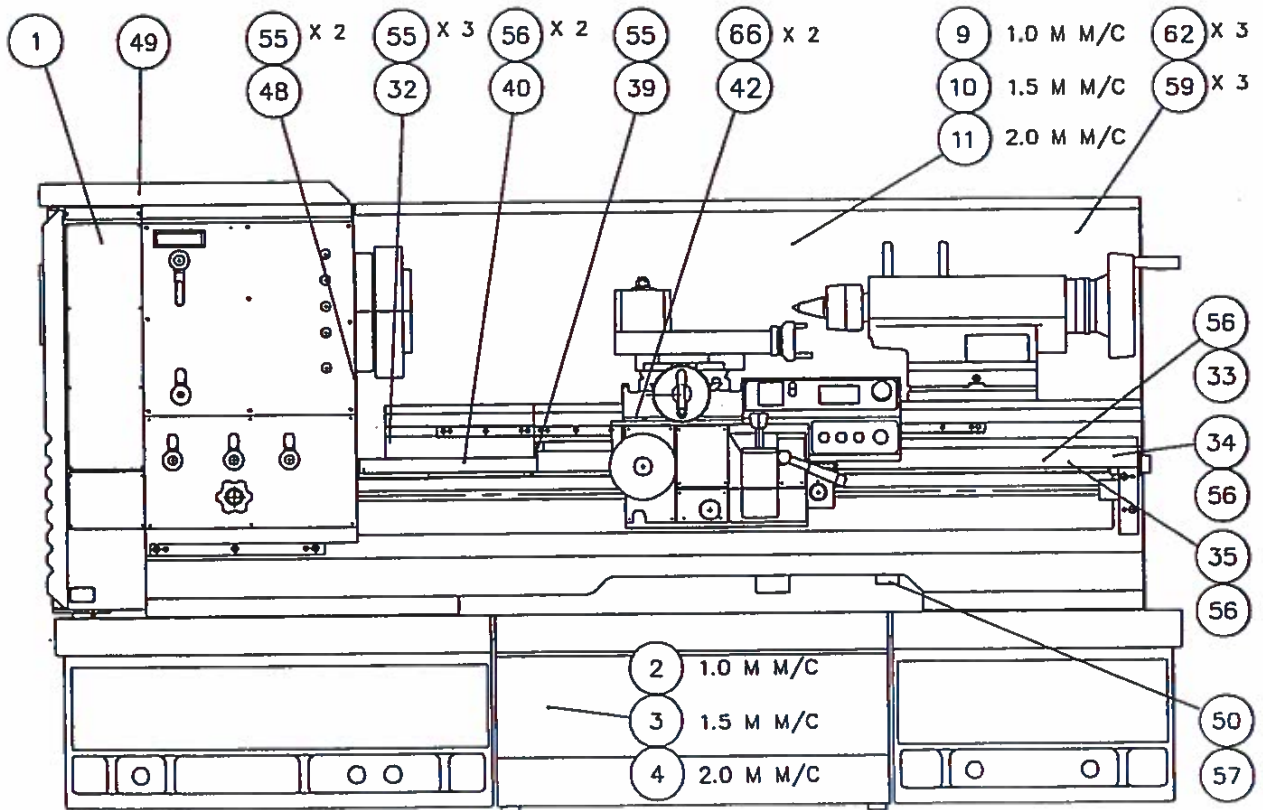
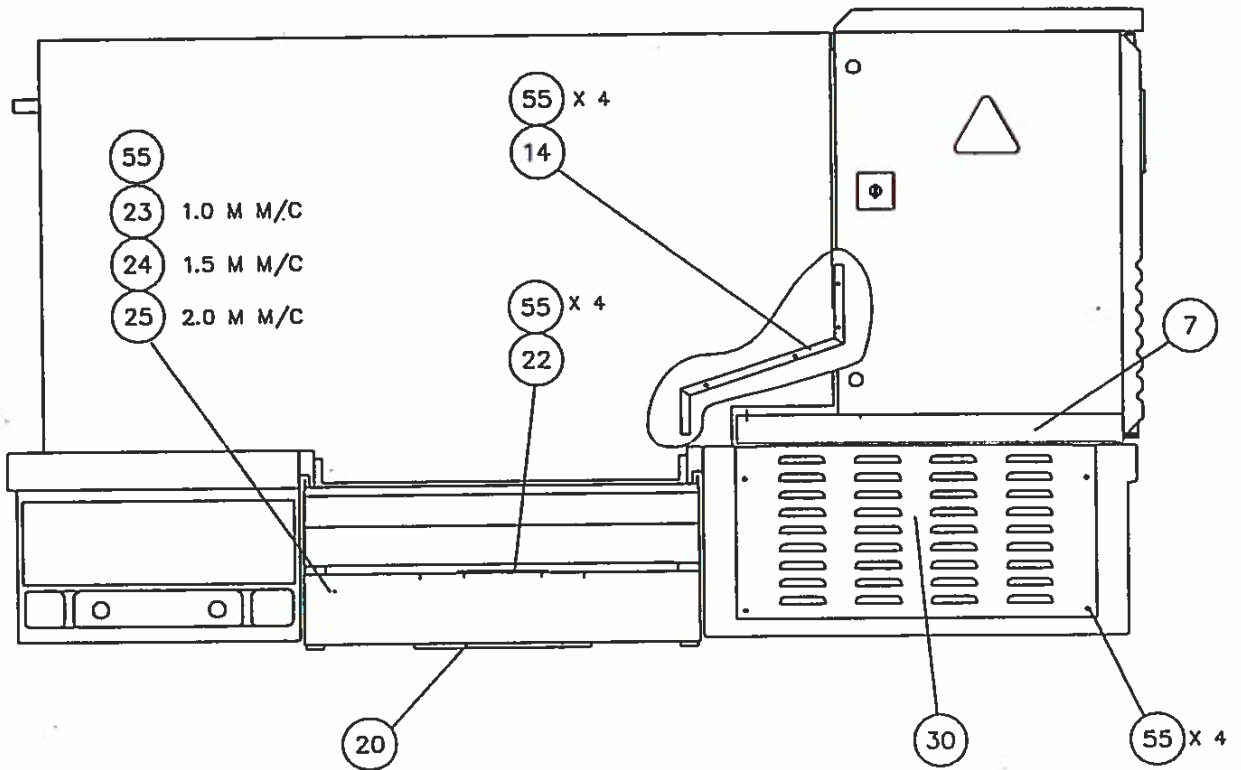

Item No.	Description	Part No.
1	HEAD END COVER	D132 - 0812
2	SWARF BIN 1.0 METRE MACHINE	D382 - 0164
3	SWARF BIN 1.5 METRE MACHINE	D382 - 0165
4	SWARF BIN 2.0 METRE MACHINE	D382 - 0166
6	SPLASHGUARD SUPPORT BRACKET	D050 - 0748
7	CABLE SUPPORT PLATE	D565 - 1071
9	SPLASHGUARD 1.0 METRE MACHINE	D346 - 0399
10	SPLASHGUARD 1.5 METRE MACHINE	D346 - 0400
11	SPLASHGUARD 2.0 METRE MACHINE	D346 - 0401
14	SPLASHGUARD BRACKET	D050 - 0750
20	STANDARD COOLANT TANK	D828 - 0061
22	PUMP MOUNTING PLATE	D565 - 0943
23	COOLANT TANK COVER 1.0 METRE MACHINE	D132 - 0816
24	COOLANT TANK COVER 1.5 METRE MACHINE	D132 - 0817
25	COOLANT TANK COVER 2.0 METRE MACHINE	D132 - 0818
28	H/E PLINTH MOTOR COVER	D132 - 0821
29	H/E PLINTH HYDRAULICS COVER	D132 - 0822
30	H/E PLINTH REAR COVER	D132 - 0823
31	T/E PLINTH COVER	D132 - 0824
32	G/BOX EXTENSION COVER	D132 - 0825
33	LEADSCREW COVER 1.0 METRE MACHINE	D132 - 0826
34	LEADSCREW COVER 1.5 METRE MACHINE	D132 - 0827
35	LEADSCREW COVER 2.0 METRE MACHINE	D132 - 0828
39	LEADSCREW COVER BRACKET	D050 - 0749
40	GAP AREA COVER	D132 - 0831
41	CHUCK GUARD MOUNTING PLATE	D565 - 1089
42	APRON DRAIN CHUTE	D147 - 0034
48	INFILL PLATE	D565 - 1062
49	HEADSTOCK TRUNKING	D132 - 0835
50	TRUNKING SUPPORT BRACKET	D050 - 0754
55	HEXAGON SOCKET BUTTON HEAD SCREW M6x10	B163 - 1813
56	HEXAGON SOCKET PLATED BUTTON HEAD SCREW M6x12	B163 - 1900
57	HEXAGON SOCKET CAP HEAD SCREW M6x16	B163 - 0037
59	HEXAGON SOCKET PLATED BUTTON HEAD SCREW M8x20	B163 - 1905
61	WASHER M6	B117 - 0048
62	WASHER M8	B117 - 0034
66	HEXAGON SOCKET BUTTON HEAD SCREW M4x10	B163 - 1804

SHEET METAL PACK (2)

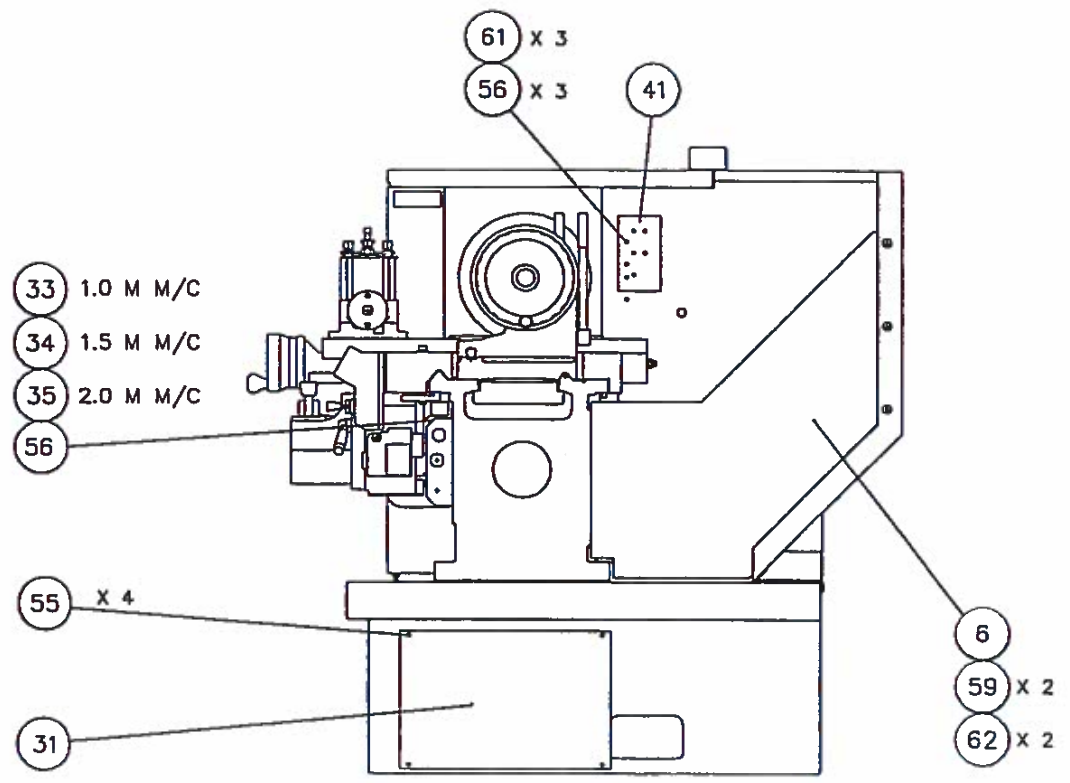
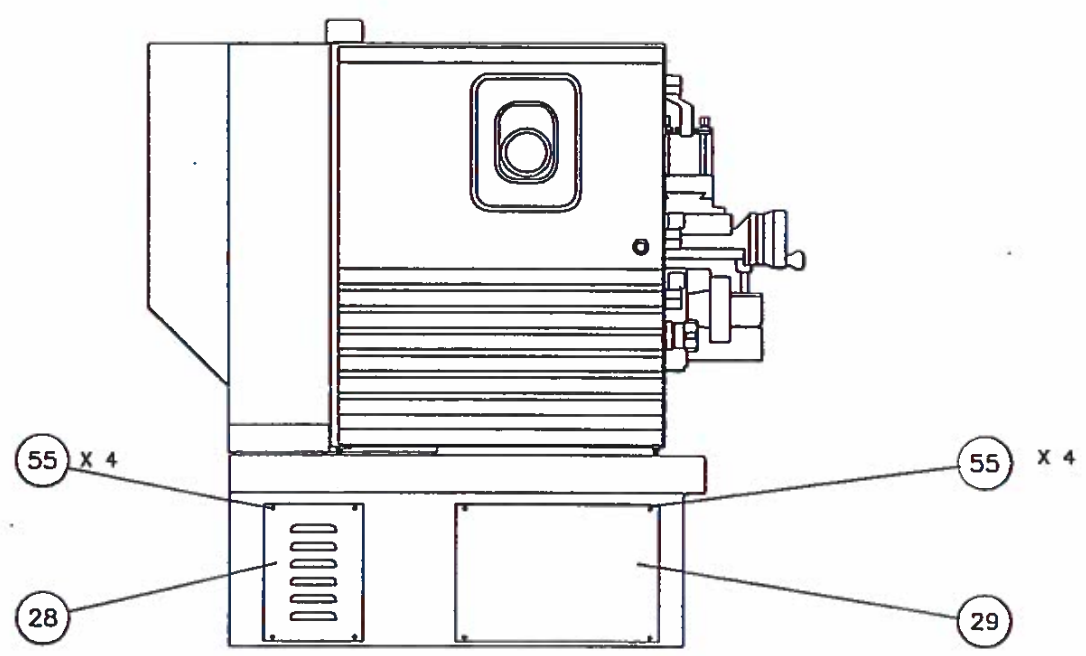

Item No.	Description	Part No.

MASCOT AND COMMON ACCESSORIES

INDEX

ITEM

1. Bedstops. Single Position
 Five Position
 Micrometer
 2. Quick Change Toolpost
 4 Way Toolpost
 3. Perspex Chipguard
 4. Stationary Steady
 5. Travelling Steady
 6. Rear Toolpost and Base
 7. Apron Dial Assembly Metric
 8. Apron Dial Assembly Inch
 9. Lighting
 10. Taper Turner
 11. Thread Dial Indicator
 12. High Speed Threading Unit Inch
 13. High Speed Threading Unit Metric
 14. Heidenhain DRO
 Magnetic Scales
 Glass Scales
-

BEDSTOPS

TURRET STOP ASSEMBLY A184 - 0516

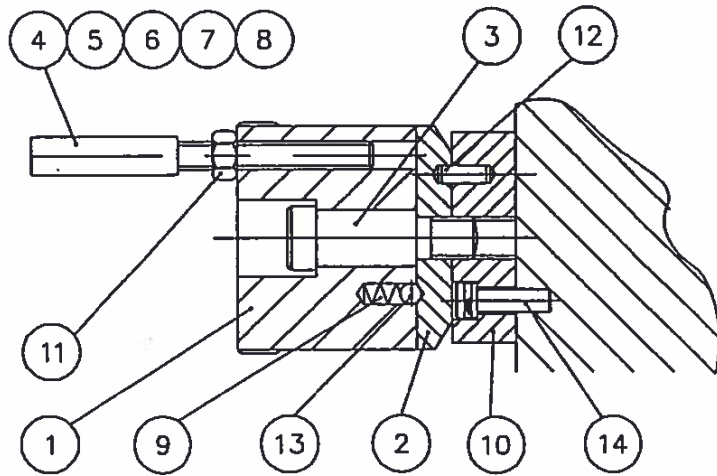

SINGLE BED STOP A184 - 0602

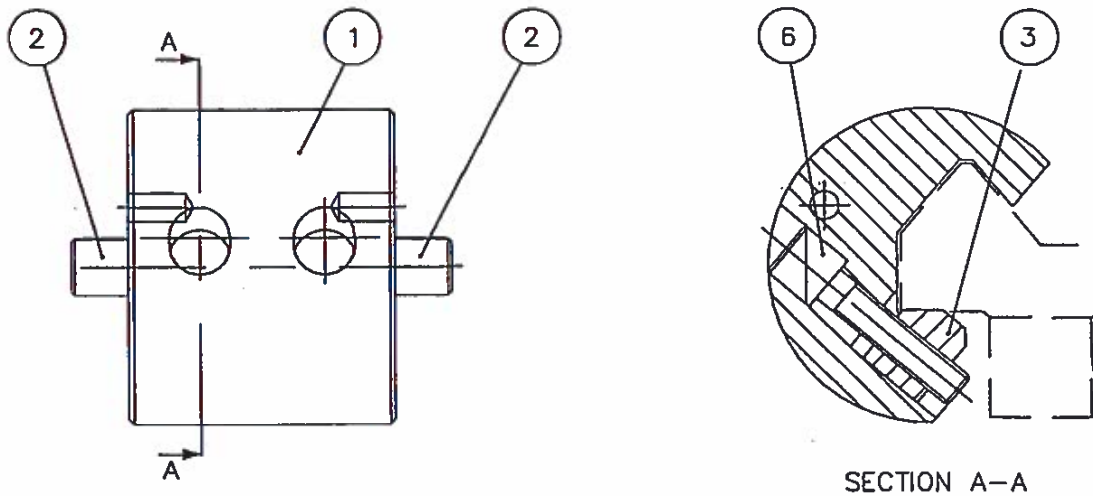

MICROMETER BED STOP A184 - 0601

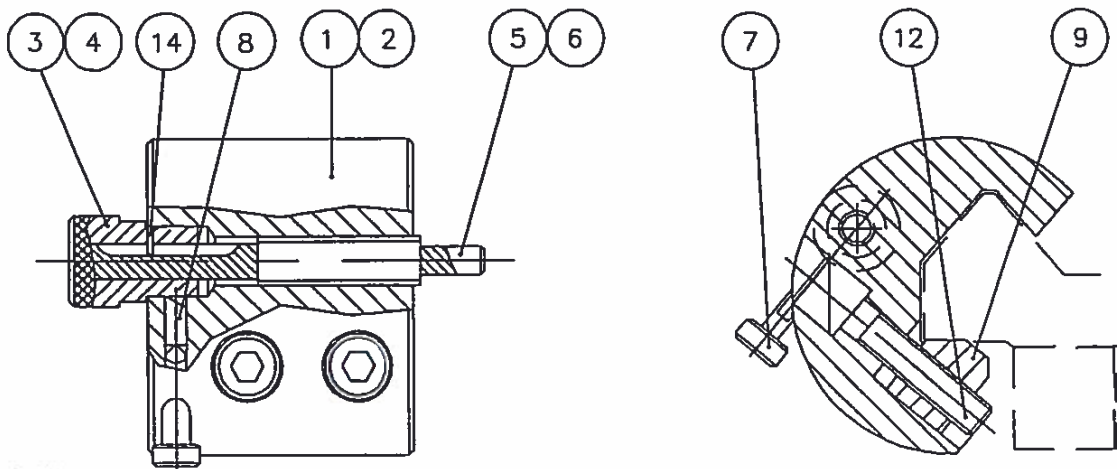

BED STOP ASSEMBLIES

A184 - 0516/0602/0601

Item No.	Description	Part No.
FIVE POSITION TURRET STOP ASSEMBLY		A184 - 0516
1	TURRET - 5 POSITION STOP	D835 - 0016
2	TURRET PLATE	D565 - 0930
3	TURRET SPINDLE	D709 - 0049
4	STOP SCREW	D697 - 0351
5	STOP SCREW	D697 - 0352
6	STOP SCREW	D697 - 0353
7	STOP SCREW	D697 - 0354
8	STOP SCREW	D697 - 0355
9	MULTI-COMPRESSION SPRING	D707 - 0033
10	SUB PLATE	D565 - 0931
11	HEXAGON LOCK NUT M8	B147 - 9170
12	SPIROL PIN 5x12 MBK	B111 - 5089
13	CYCLE BALL BEARING 1/4"	B326 - 8107
14	HEXAGON SOCKET CAP HEAD SCREW M6 x20	B163 - 0038
SINGLE BED STOP ASSEMBLY		A184 - 0602
1	BED STOP BODY	D712 - 0038
2	PAD - BED STOP	D557 - 0082
3	CLAMP - BED STOP	D131 - 0019
6	HEXAGON SOCKET CAP HEAD SCREW 3/8"x11/2"	B163 - 7069
MICROMETER BED STOP ASSEMBLY		A184 - 0601
1	MICROMETER BED STOP (IMPERIAL)	D712 - 0039
2	MICROMETER BED STOP (METRIC)	D712 - 0036
3	THIMBLE (IMPERIAL)	D382 - 0069
4	THIMBLE (METRIC)	D382 - 0073
5	STOP ROD (IMPERIAL)	D648 - 0052
6	STOP ROD (METRIC)	D648 - 0055
7	CLAMP SCREW	D697 - 0183
8	WEDGE PIN	D560 - 0128
9	CLAMP	D131 - 0019
12	HEXAGON SOCKET CAP HEAD SCREW 3/8"x11/2"	B143 - 7069
14	DOWEL PIN 1/8" X 1/4"	B111 - 1041

QUICK CHANGE TOOLPOST

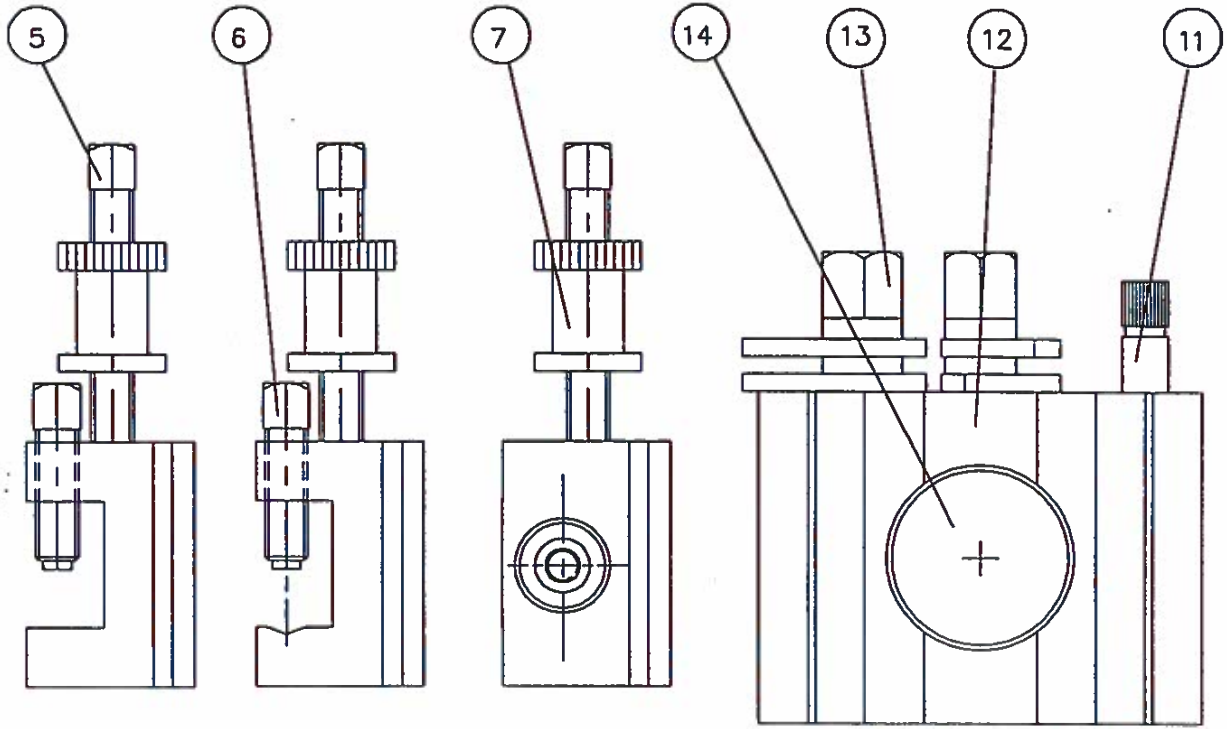

- 4
- STANDARD
- 16
- VEE
- 3
- No.3 MORSE TAPER

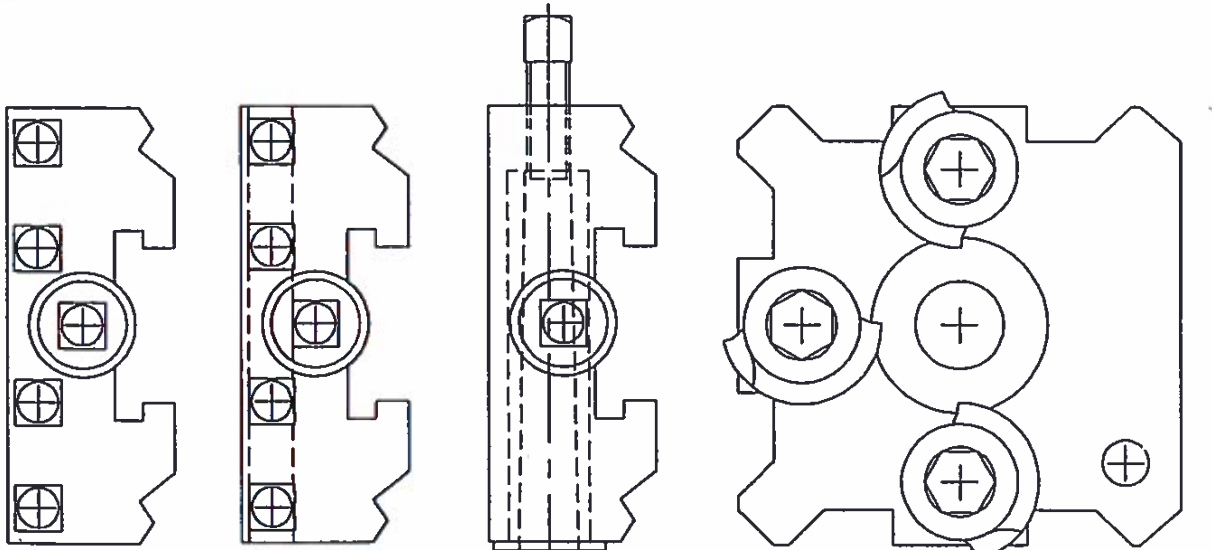

ADDITIONAL TOOLHOLDERS

- 1
- PARTING OFF TOOLHOLDER
- 2
- Parting Off Blade
- 8
- BORING TOOLHOLDER

WRENCHES

- 9
- TOOL CLAMP SCREW
- 10
- CAM CLAMP

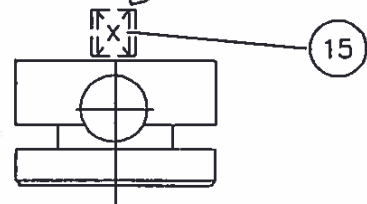

QUICK CHANGE TOOLPOST

Item No.	Description	Part No.

FOUR WAY TOOLPOST

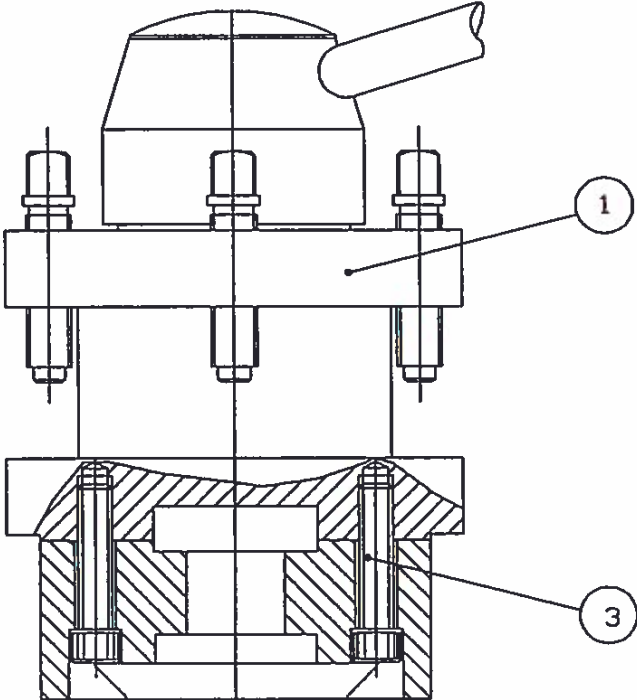
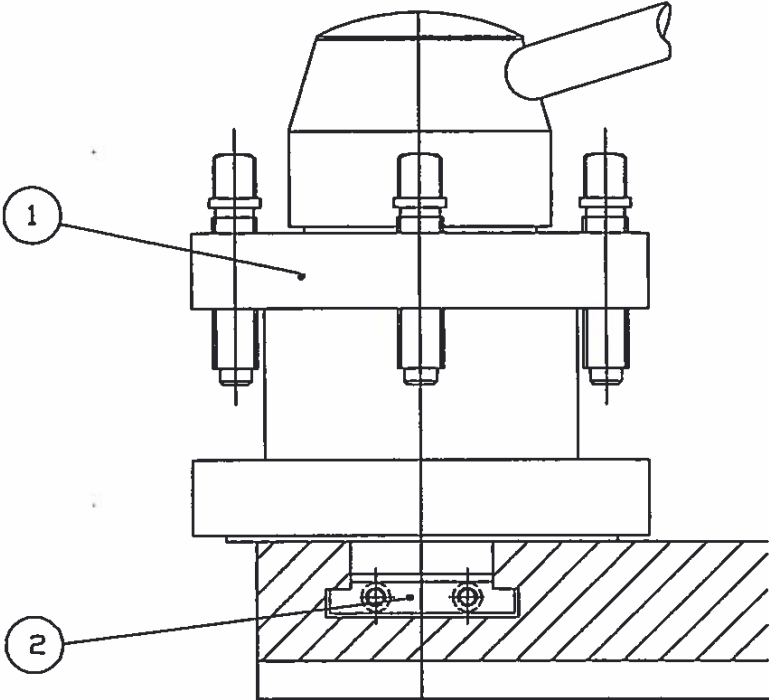

FOUR WAY TURRET TOOLPOST

A182 - 0606

Item No.	Description	Part No.
1	TYPE T4 FOUR WAY TURRET TOOLPOST COMPLETE	B935 - 1139
2	TEE NUTS FOR SLOTTED TOPSLIDE	B935 - 1438
3	HEXAGON SOCKET CAP HEAD SCREW 3/8"UNCx1 1/2" LONG	B143 - 7069

PERSPEX CHIP GUARD

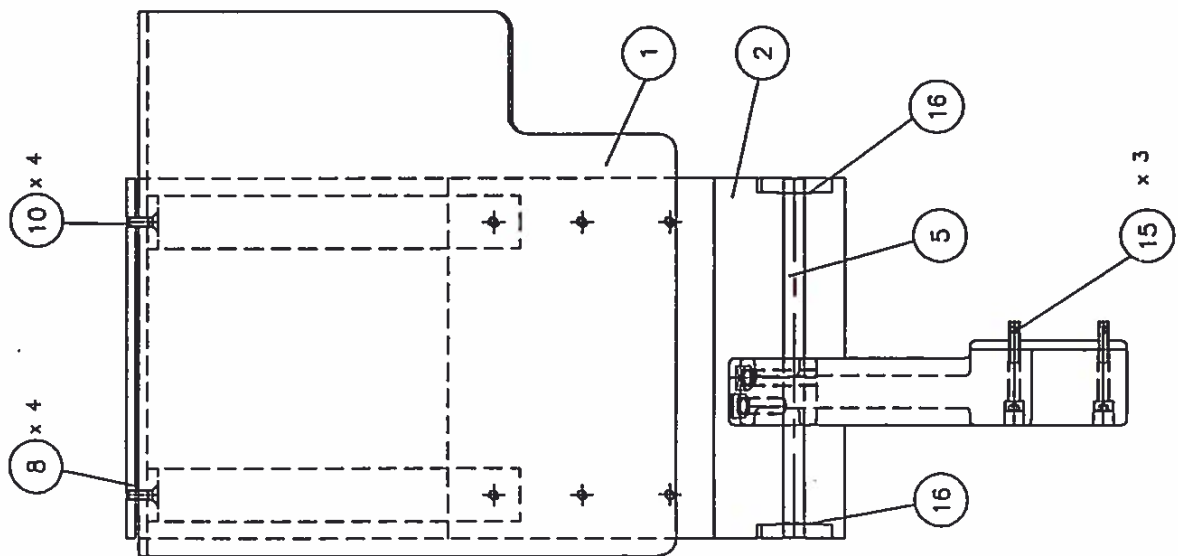
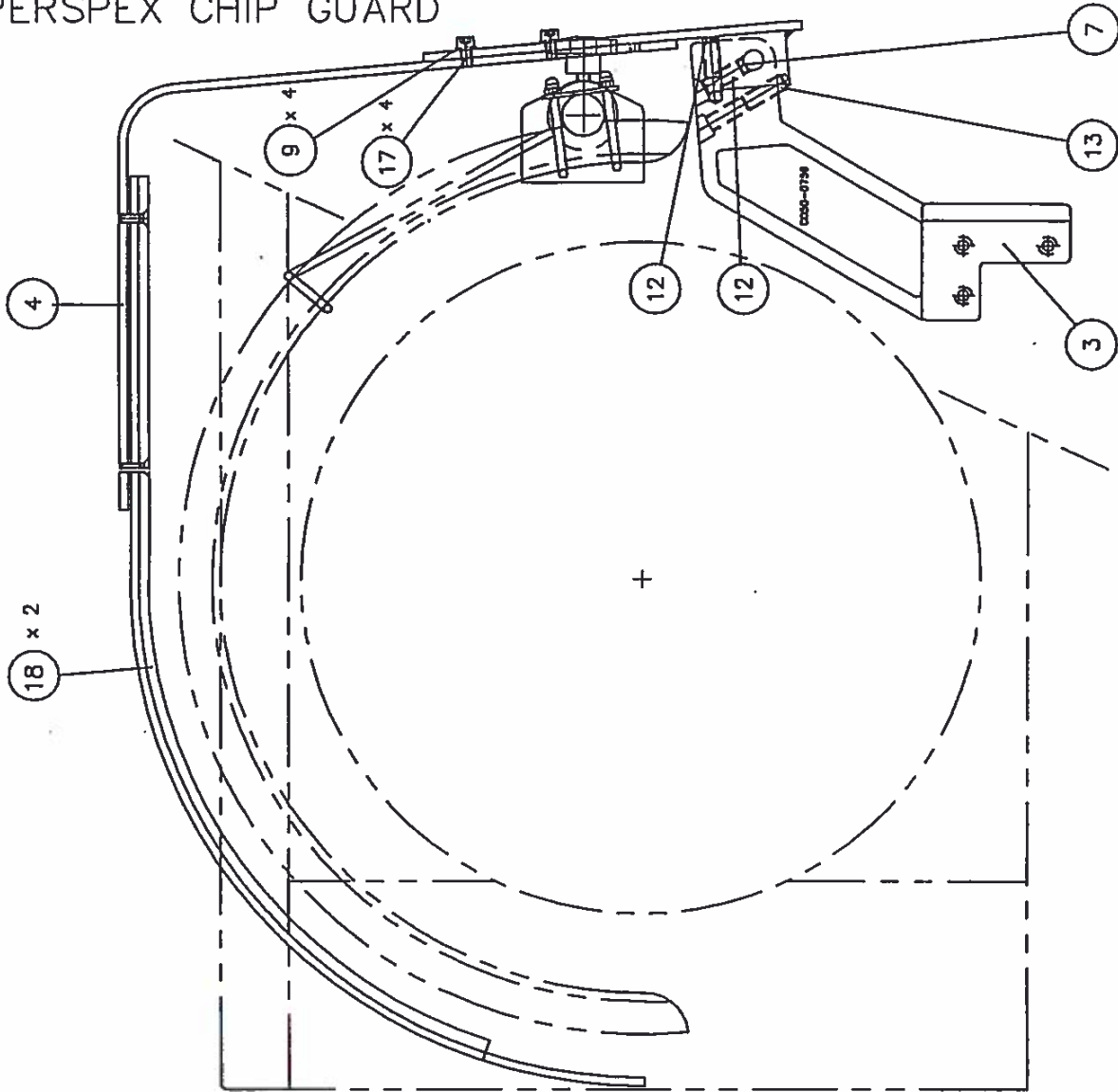

PERSPEX CHIP GUARD ASSEMBLY

A137 - 0622

Item No.	Description	Part No.
1	PERSPEX CHIP GUARD	D346 - 0403
2	LOWER SUPPORT	D718 - 0080
3	BRACKET	D050 - 0759
4	UPPER SUPPORT	D718 - 0081
5	SHAFT	D699 - 0820
7	PLUG	D566 - 0203
8	FIBRE WASHER 1/4" IDx1/2" OD	B411 - 0006
9	WASHER M6	B117 - 0009
10	HEXAGON SOCKET COUNTER SUNK SCREW M5x16	B163 - 1016
12	W/POINT SET SCREW M10x25	B163 - 1588
13	HEXAGON SOCKET DOG POINT SET SCREW M10x30	B163 - 1766
15	HEXAGON SOCKET CAP HEAD SCREW M6x45	B163 - 0043
16	CIRCLIP 1400-12	B363 - 0012
17	HEXAGON SOCKET CAP HEAD SCREW M6x12	B163 - 0036
18	SUPPORT BAR	D041 - 0251

STATIONARY STEADY

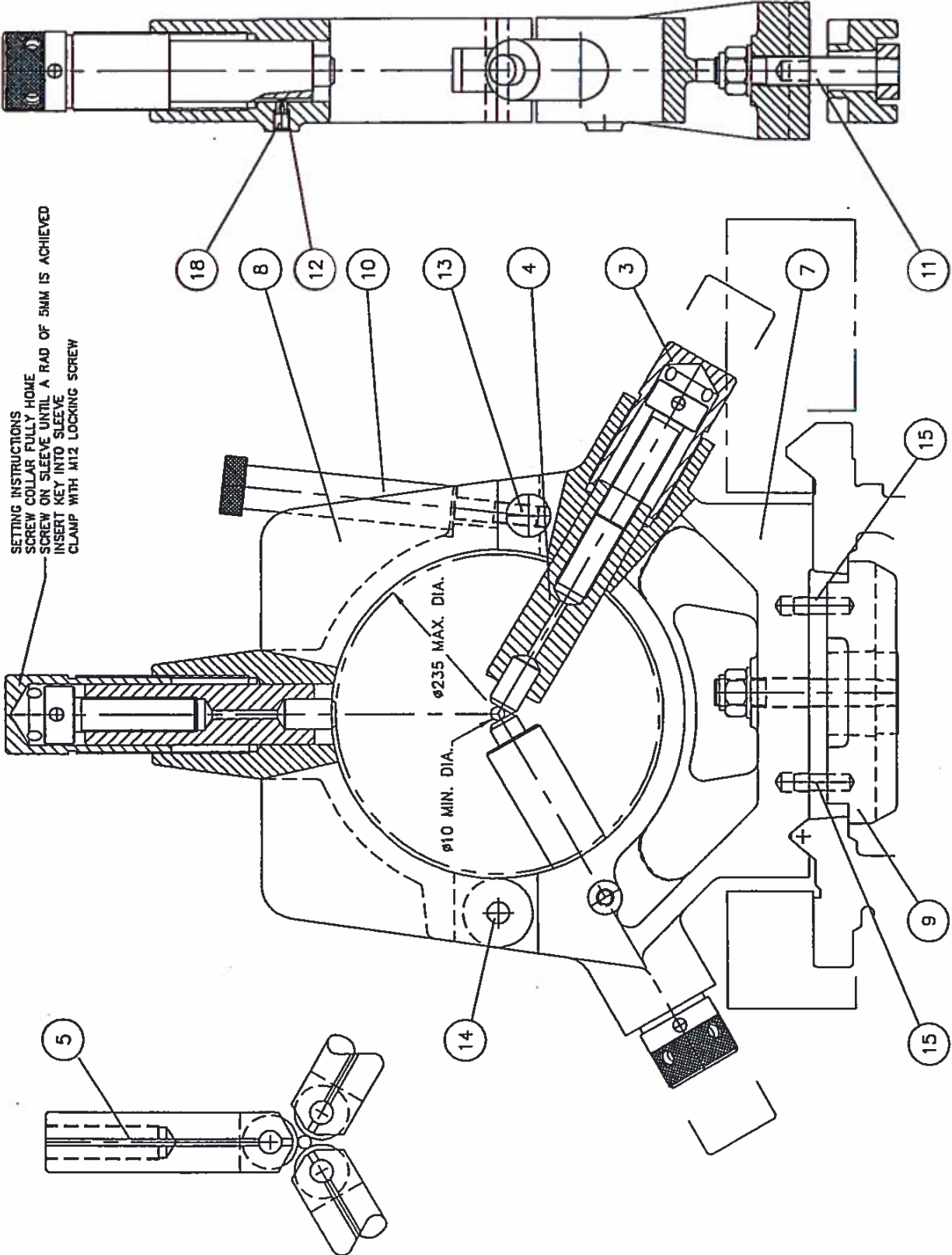

STATIONARY STEADY

A178 - 0611

Item No.	Description	Part No.
3	COLLAR SUB-ASSEMBLY	A820 - 0006
4	PAD TYPE FINGER SUB-ASSEMBLY	A882 - 0068A
5	ROLLER TYPE FINGER SUB-ASSEMBLY	A882 - 0068B
7	STEADY BASE	D722 - 0066
8	STEADY TOP	D722 - 0067
9	CLAMP PLATE	D131 - 0043
10	CLAMP SCREW	D697 - 0388
11	CLAMP STUD ASSEMBLY	A840 - 0053
12	KEY	D441 - 0082
13	PIN	D560 - 0321
14	HINGE PIN	D560 - 0322
15	SPIROL PIN 12x40	B111 - 5167
18	DOG POINT SCREW M12x12	B163 - 1780
19	WASHER M20	B117 - 0014
20	NYLOC NUT M20	B147 - 9010
	COLLAR SUB-ASSEMBLY	A820 - 0006
1	COLLAR	D133 - 0256
2	ADJUSTING SCREW	D697 - 0389
4	STEEL DOWEL 10x55	B111 - 6117
	PAD TYPE FINGER SUB-ASSEMBLY	A882 - 0068A
1	PAD FINGER	D300 - 0036
2	PAD	D421 - 0022
	ROLLER TYPE FINGER SUB-ASSEMBLY	A882 - 0068B
4	ROLLER FINGER	D300 - 0037
5	BEARING INA NATR 17PP	B337 - 1711
6	PIN	D560 - 0323
7	CONCAVE LUBRICATOR 6mm DIA.	B454 - 2004
8	HEXAGON SOCKET SET SCREW M4x8	B163 - 1511
	CLAMP STUD ASSEMBLY	A840 - 0053
1	STUD	D711 - 0206
2	STUD PLATE	D565 - 1056
3	SPIROL PIN 5x36	B111 - 5099

TRAVELLING STEADY

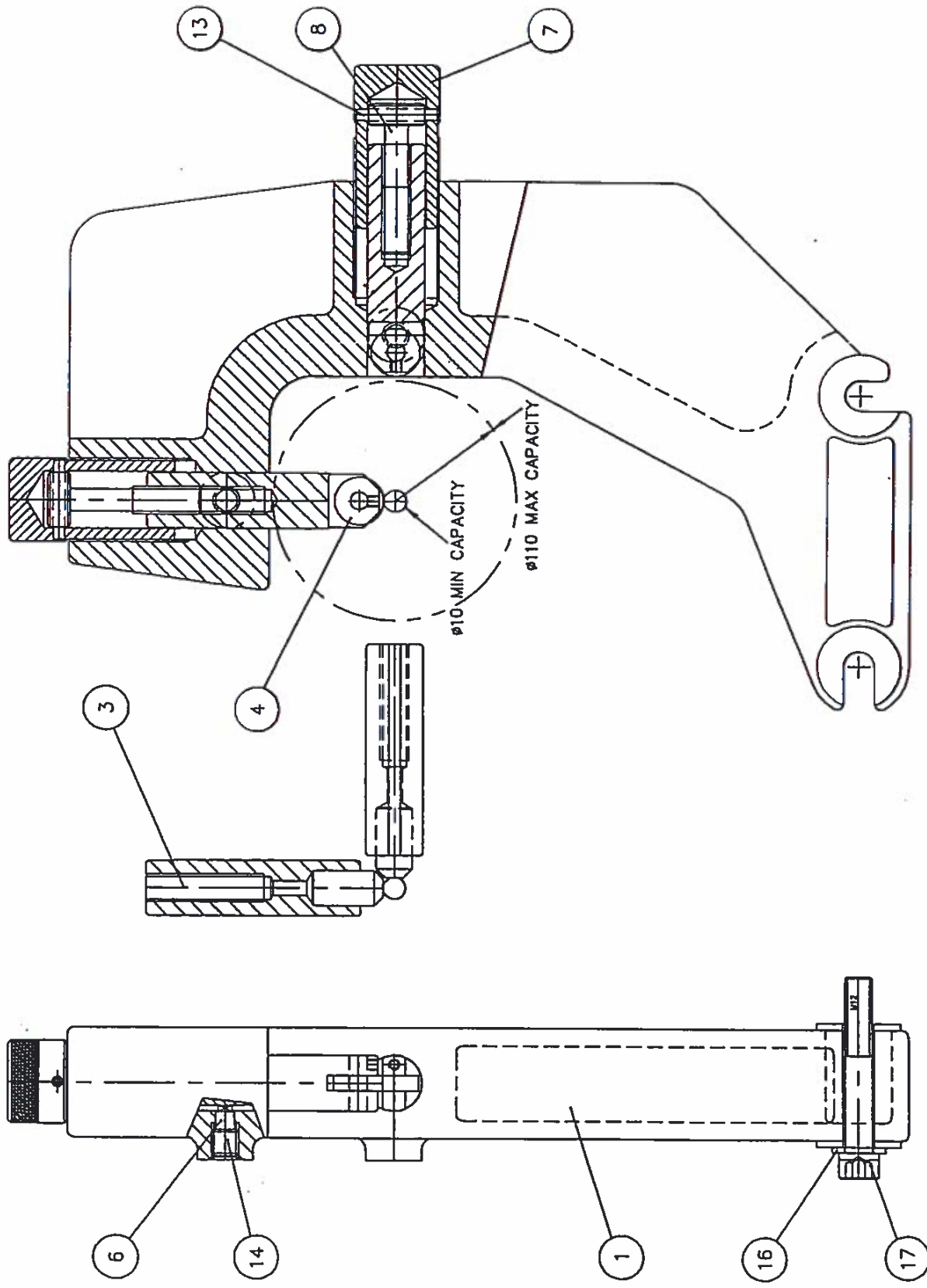

TRAVELLING STEADY

A178 - 0610

Item No.	Description	Part No.
1	TRAVELLING STEADY CASTING	D722 - 0071
3	PAD TYPE FINGER SUB -ASSEMBLY	A882 - 0069A
4	ROLLER TYPE FINGERSUB -ASSEMBLY	A882 - 0069B
6	KEY	D441 - 0082
7	COLLAR	D133 - 0257
8	SCREW	D697 - 0390
13	SPIROL PIN 5x36	B111 - 5099
14	DOG POINT SCREW M12x12	B163 - 1780
16	WASHER M12	B117 - 0012
17	HEXAGON SOCKET CAP HEAD SCREW M12x80	B163Y0094
<p style="text-align: center;">PAD TYPE FINGER SUB-ASSEMBLY A882 - 0069A</p>		
1	PLAIN FINGER	D300 - 0038
2	PAD	D421 - 0023
<p style="text-align: center;">ROLLER TYPE FINGER SUB-ASSEMBLY A882 - 0069B</p>		
5	ROLLER FINGER	D300 - 0039
6	PIN	D560 - 0324
9	BEARING FAG 6082Z	B315 - 0208
10	HEXAGON SOCKET CUP POINT SET SCREW M5x5	B163 - 1547

REAR TOOLPOST ASSEMBLY

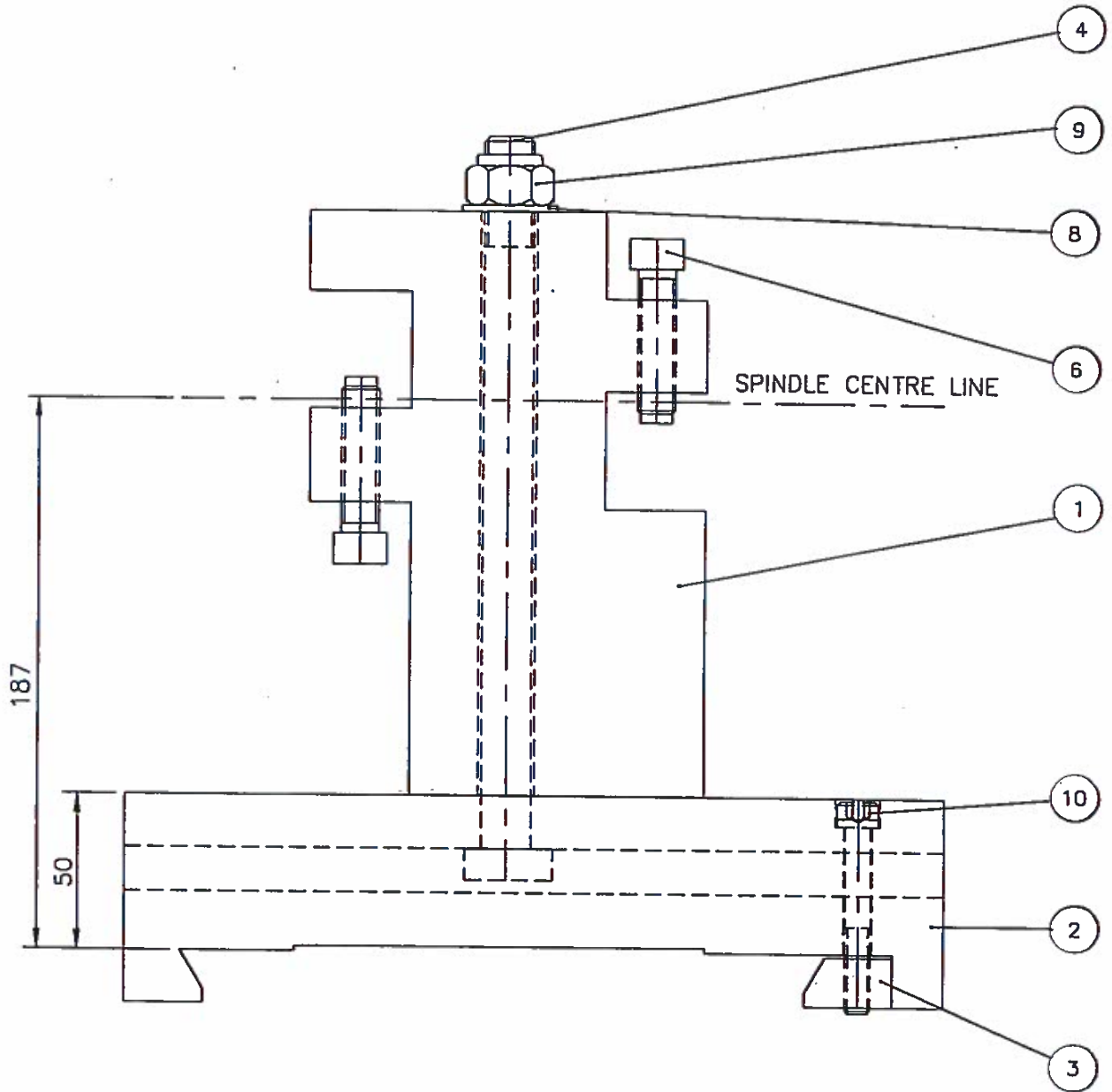

REAR TOOLPOST ASSEMBLY

A182 - 0614

Item No.	Description	Part No.
1	REAR TOOLPOST BODY	D831 - 0064
2	BASE PLATE	D565 - 1086
3	GIB STRIP	D345 - 0094
4	TEE BOLT	D048 - 0167
6	SQUARE HEAD SET SCREW M12x50	B170 - 0005
8	WASHER M16	B117 - 0013
9	NYLOC NUT M16	B147Y9027
10	HEXAGON SOCKET CAP HEAD SCREW M8x60	B163Y0061

Item No.	Description	Part No.

LO-VO LIGHT ASSEMBLY

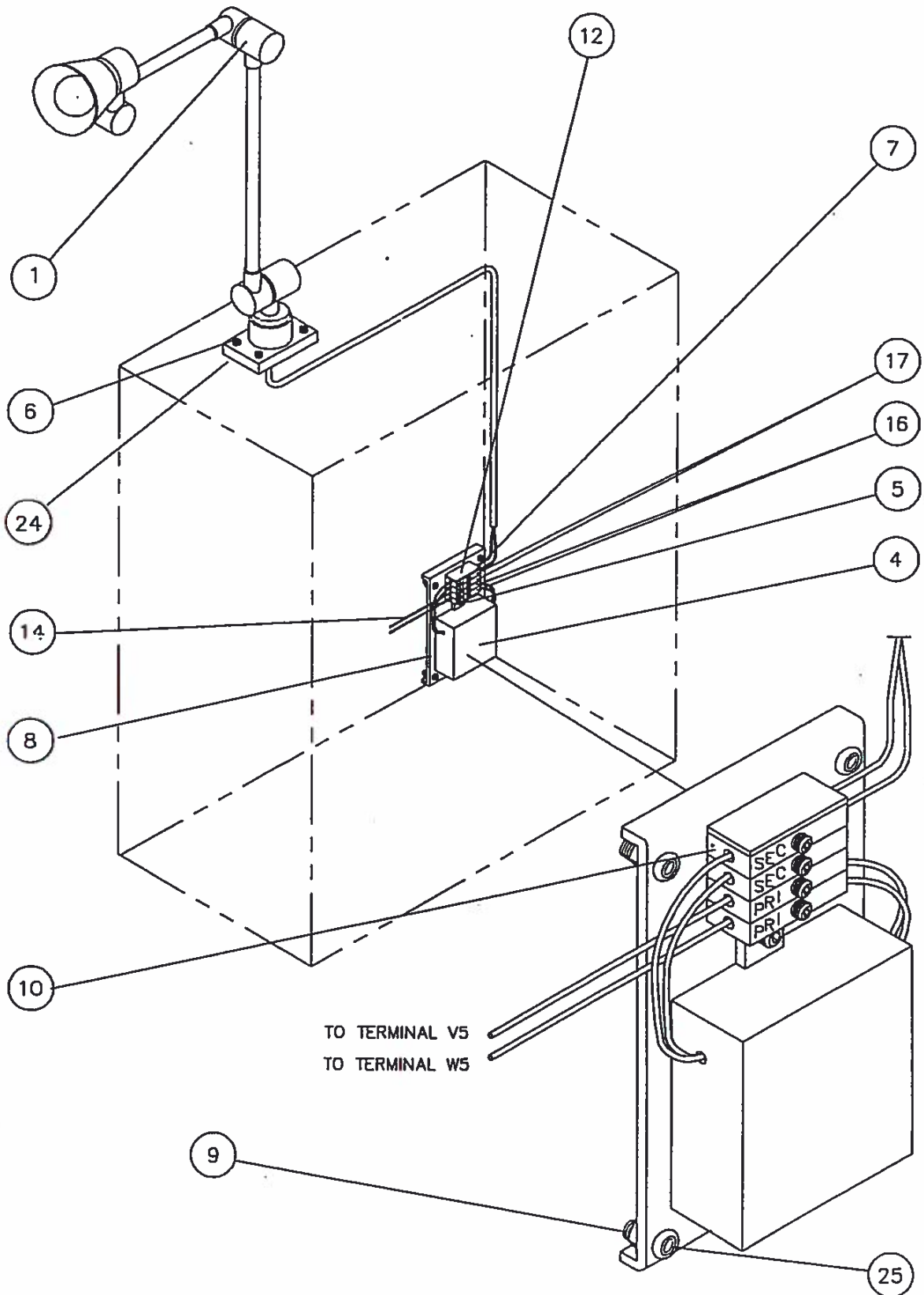

LO-VO LIGHT ASSEMBLY

A170-0-0505

Item No.	Description	Part No.
1	LO-VO LITE	B784 - 1140
4	TRANSFORMER 415v PRIMARY 50v SECONDARY	B772 - 3019
5	HEXAGON SOCKET CAP HEAD SCREW M4x8	B163 - 1803
6	HEXAGON SOCKET CAP HEAD SCREW M5x20	B163 Y0028
7	HEXAGON SOCKET CAP HEAD SCREW M3x8	B163Y0003
8	PLATE	D565 - 0920
9	NYLOC NUT M4	B147Y9001
10	FUSE BLOCK KLIPPON AŞK 1	B718 - 2047
12	END PLATE KLIPPON AP(1.5)	B718 - 2048
14	PVC 1.0mm SQ. WIRE RED	R512 - 6002
16	FUSE R.S. 413-973 20mm 2A	B752 - 1237
17	FUSE R.S. 413-967 20mm 1A	B752 - 1235
24	NYLOC NUT M5	B147 - 9002
25	HEXAGON SOCKET BUTTON HEAD SCREW M4x16	B163 - 1806

LO-V0 LIGHT ASSEMBLY (HALOGEN)

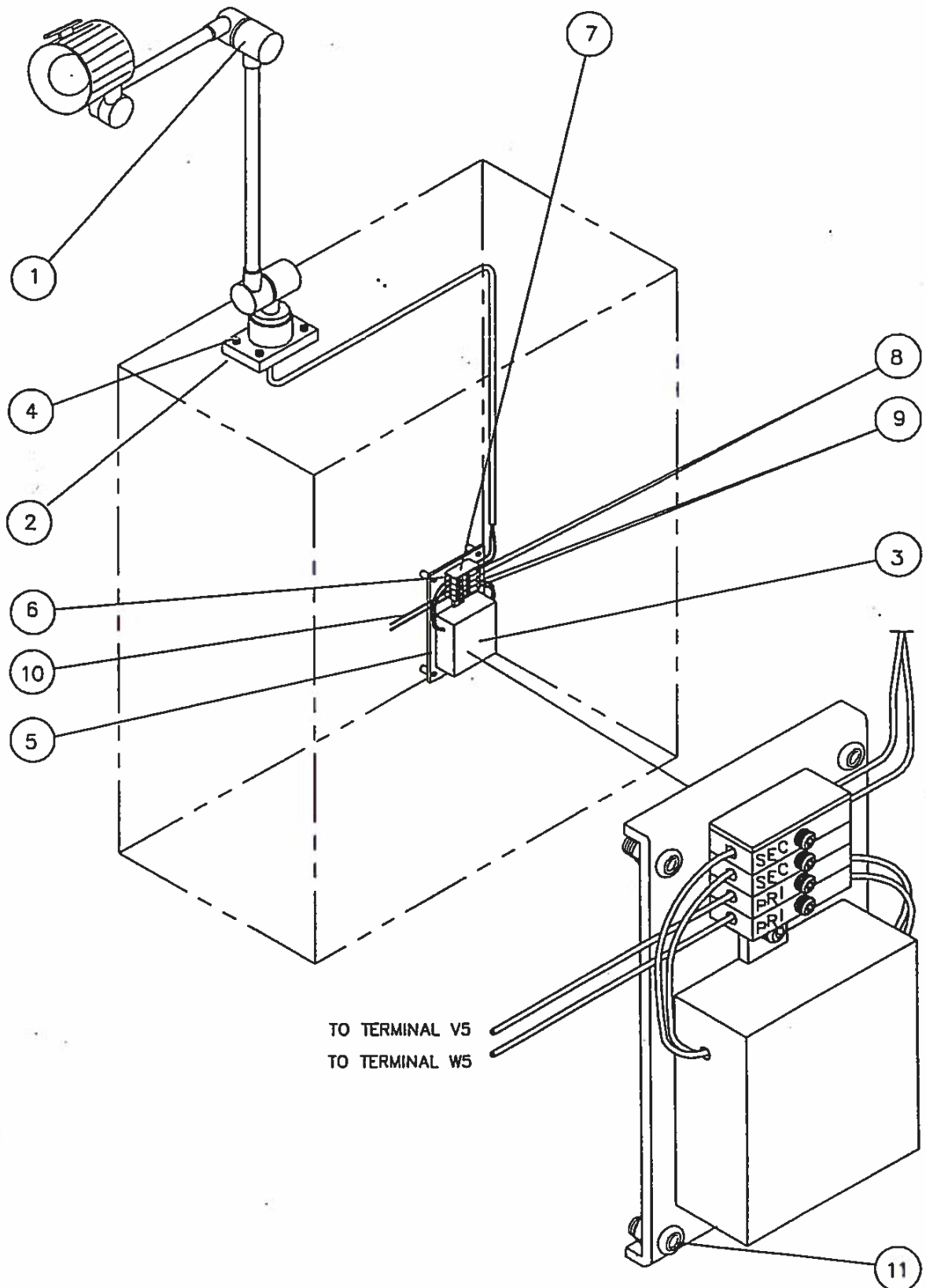

LO - VO LIGHT ASSEMBLY (HALOGEN)

A170 - 0506

Item No.	Description	Part No.
1	HALOGEN LIGHT HGW 70-N	B784 - 1226
2	ADAPTOR BLOCK	D047 - 0124
3	TRANSFORMER 63VA.380V/23V	B772 - 3023
4	HEXAGON SOCKET CAP HEAD SCREW M5x16	B163 - 0027
5	PLATE	D565 - 0920
6	FUSE BLOCK KLIPPON ASK 1	B718 - 2047
7	END PLATE KLIPPON AP(1.5)	B718 - 2048
8	FUSE R.S. 413-973 20mm 1A	B752 - 1235
9	FUSE R.S. 413-967 20mm 2A	B752 - 1237
10	PVC 1.0mm SQ. WIRE RED	R512 - 6002
11	HEXAGON SOCKET CAP HEAD SCREW M3x8	B163 Y0003

TAPER TURNER ASSEMBLY

CAPACITY - 400mm STROKE @ 10 DEGREES

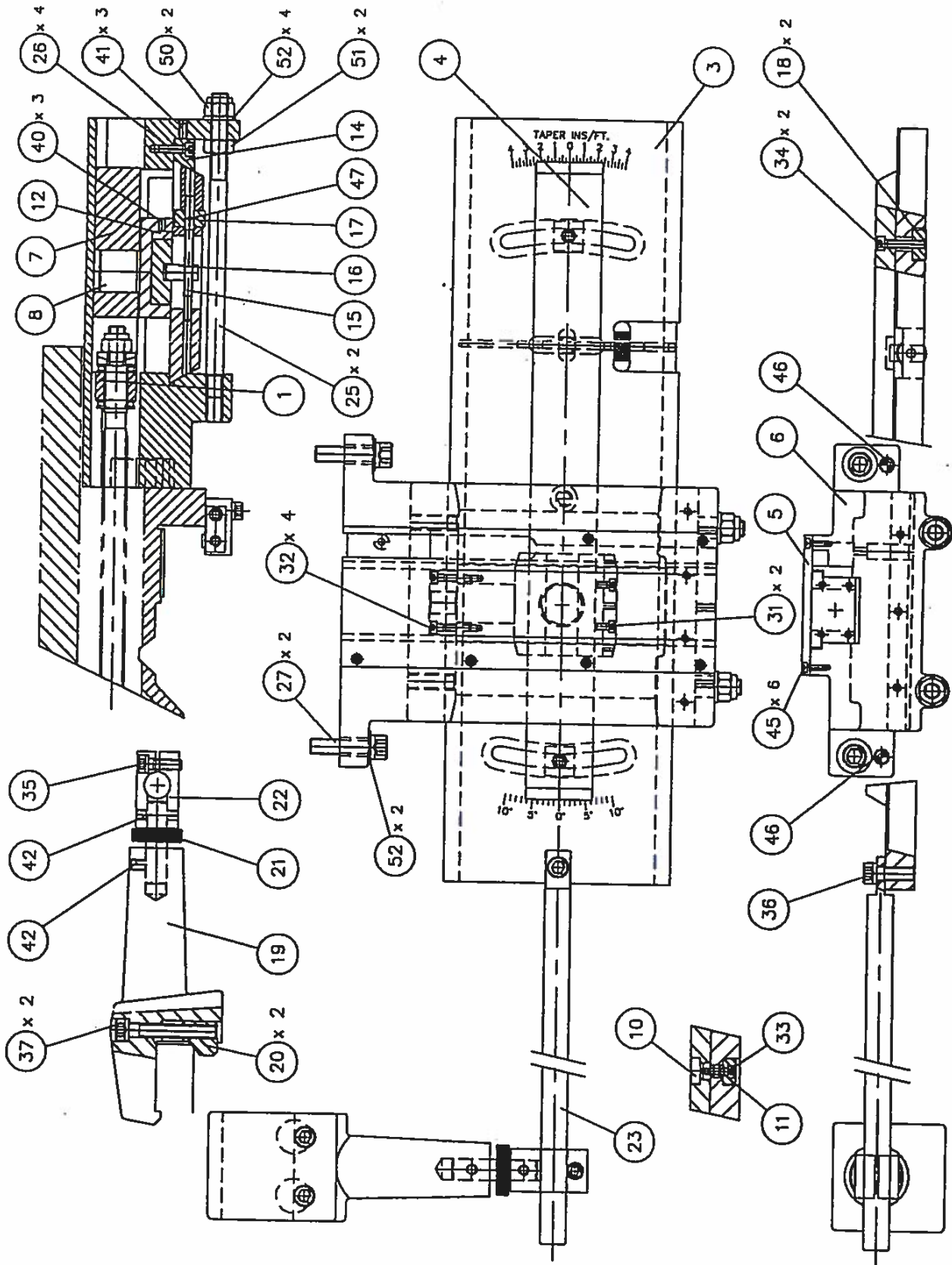

TAPER TURNER ASSEMBLY

A186 - 0628

Item No.	Description	Part No.
1	HOUSING PLATE SUB ASSEMBLY	A806 - 0580A
3	GRADUATED PLATE	D565 - 1083
4	GRADUATED SLIDE	D705 - 0141
5	COVER PLATE	D565 - 1084
6	SUPPORT BRACKET	D050 - 0755
7	SLIDE	D705 - 0142
8	SLIDING BLOCK	D047 - 0140
10	PIVOT PEG	D572 - 0024
11	RETAINING WASHER	D931 - 0348
12	GIB STRIP	D715 - 0199
14	GIB STRIP	D715 - 0051
15	ADJUSTING SCREW	D697 - 0356
16	PIVOT NUT	D536 - 0334
17	ADJUSTING KNOB	D443 - 0044
18	CLAMP NUT	D047 - 0139
19	ANCHOR BRACKET	D050 - 0756
20	ANCHOR BRACKET CLAMP	D047 - 0099
21	ECCENTRIC PIN	D271 - 0007
22	CLAMP BRACKET	D050 - 0653
23	CONNECTING ROD	D648 - 0093
25	STUD	D648 - 0102
26	HEXAGON SOCKET CAP HEAD SCREW M6x20	B163 - 0038
31	HEXAGON SOCKET CAP HEAD SCREW M5x8	B163 - 0024
32	HEXAGON SOCKET CAP HEAD SCREW M5x25	B163Y0028
33	HEXAGON SOCKET CAP HEAD SCREW M6x16	B163 - 0037
34	HEXAGON SOCKET CAP HEAD SCREW M6x30	B163 - 0040
35	HEXAGON SOCKET CAP HEADS CREW M8x25	B163 - 0054
36	HEXAGON SOCKET CAP HEADSCREW M10x30	B163Y0068
37	HEXAGON SOCKET CAP HEAD SCREW M10x65	B163 - 0076
40	HEXAGON SOCKETSETSCREW M5x8	B163 - 1518
41	HEXAGON SOCKETSETSCREW M6x10	B163 - 1545
42	'W' POINT SET SCREW M8x 8	B163 - 1572
45	HEXAGON SOCKET CAP HEAD SCREW M4x8	B163 - 0013
46	DOWEL 10 DIAx45	B111 - 6310
47	SPIROL PIN 3 DIA.x20	B111Y5060
50	NYLOC NUT M12	B147Y9006
51	NUT M12	B147 - 9172
52	WASHER M12	B117 - 0012

METRIC THREAD DIAL INDICATOR ASSEMBLY

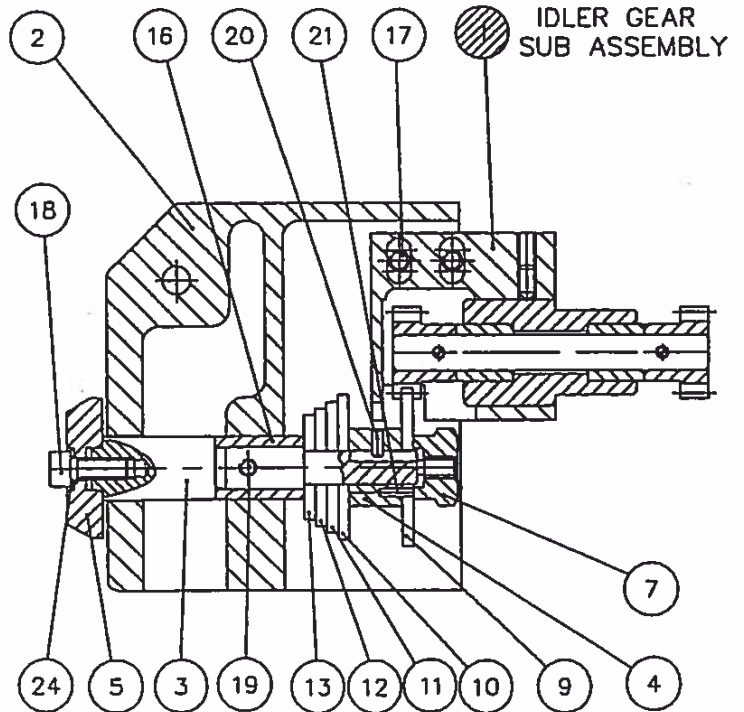
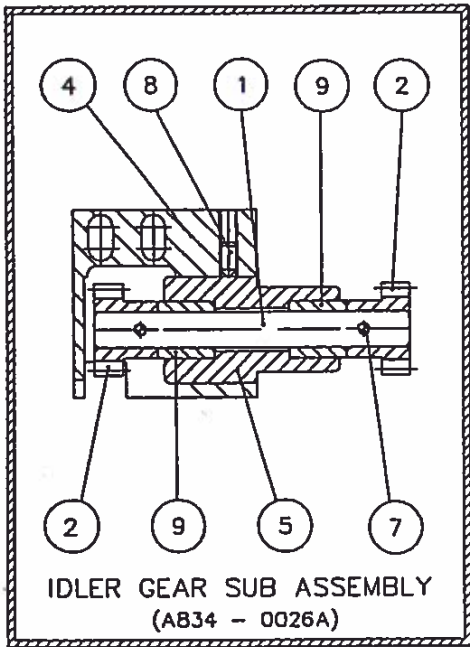
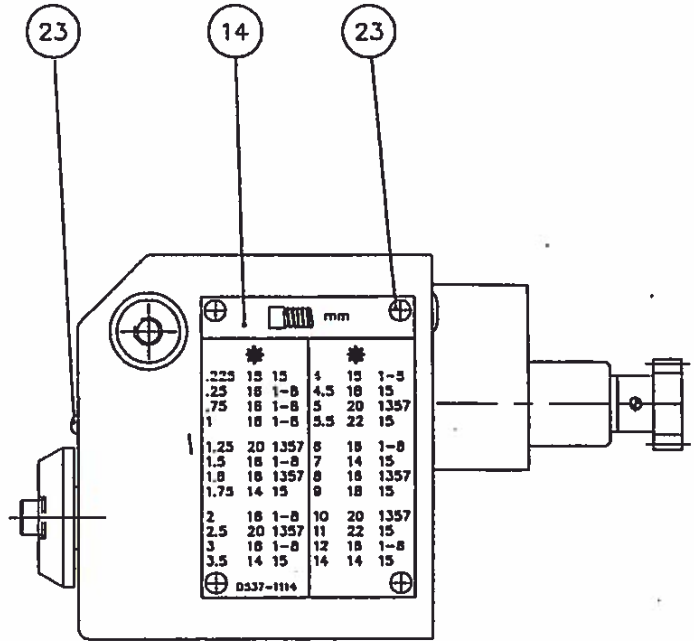
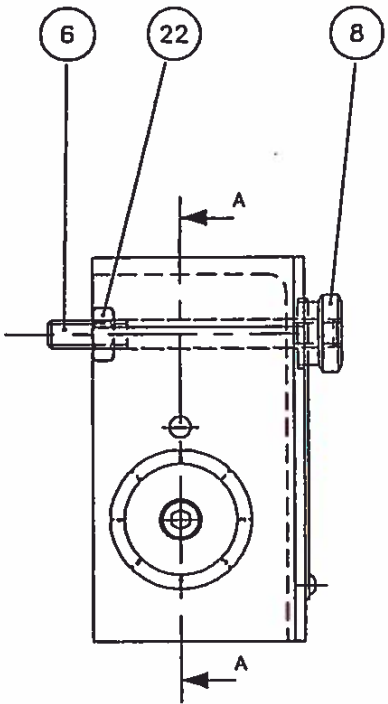

SECTION A-A

METRIC THREAD DIAL INDICATOR ASSEMBLY

A143 - 0606

Item No.	Description	Part No.
1	IDLER GEAR SUB ASSEMBLY	A834 - 0026A
2	HOUSING	D388 - 0141
3	SHAFT	D699 - 0819
4	SPACER	D708 - 0525
5	DIAL	D232 - 0036
6	STUD	D711 - 0205
7	THUMB NUT	D536 - 0335
8	THUMB NUT	D536 - 0336
9	22 TOOTH GEAR	D344 - 0755
10	20 TOOTH GEAR	D344 - 0756
11	18 TOOTH GEAR	D344 - 0757
12	16 TOOTH GEAR	D344 - 0758
13	14 TOOTH GEAR	D344 - 0759
14	PLATE	D537 - 1114
16	OILITE BUSH CM22x25	B311 - 2022
17	HEXAGON SOCKET CAP HEAD SCREW M6x50	B163 - 0044
18	HEXAGON SOCKET CAP HEAD SCREW M6x12	B163 - 0036
19	HEXAGON SOCKET CONE POINT SET SCREW M5x10	B163 - 1644
20	SPIROL PIN 3 DIA.x8	B111 - 5054
21	SPIROL PIN 3/32"DIA.x5/16"	B111 - 2419
22	NUT M8	B147 - 9153
23	SELF TAPPING SCREW No.4x1/4"	B123 - 2272
24	CRINKLE WASHER M6	B117 - 0107
	IDLER GEAR SUB ASSEMBLY	A834 - 0026A
1	IDLER GEARS SHAFT	D699 - 0818
2	METRIC 12 TOOTH GEAR	D344 - 1321
4	IDLER GEAR HOUSING	D388 - 0142
5	IDLER GEAR SHAFT SLEEVE	D704 - 0135
7	SPIROL PIN 3 DIA.x16	B111 - 5058
8	HEXAGON SOCKET CONE POINT SET SCREW M5x10	B163 - 1644
9	OILITE BUSH CM 20x16	B311 - 2021

IMPERIAL THREAD DIAL INDICATOR ASSEMBLY

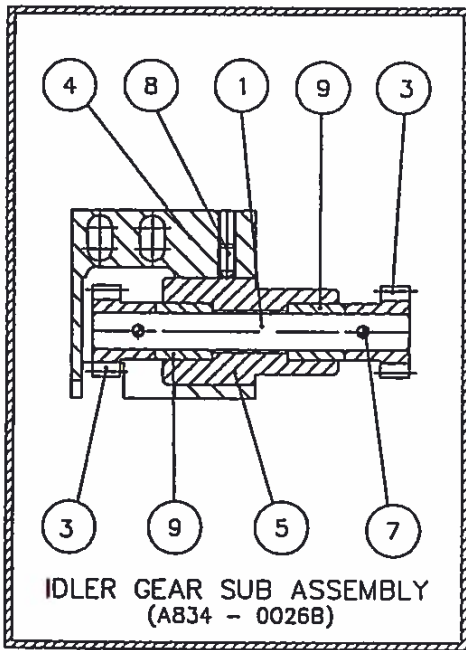
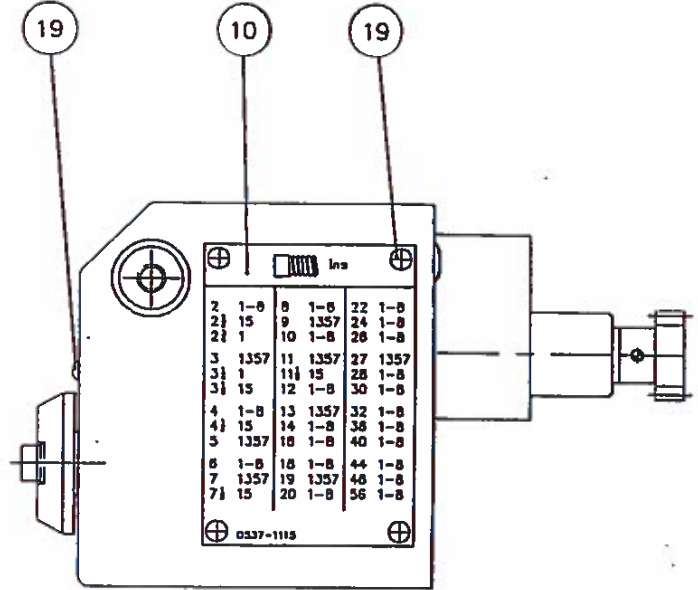
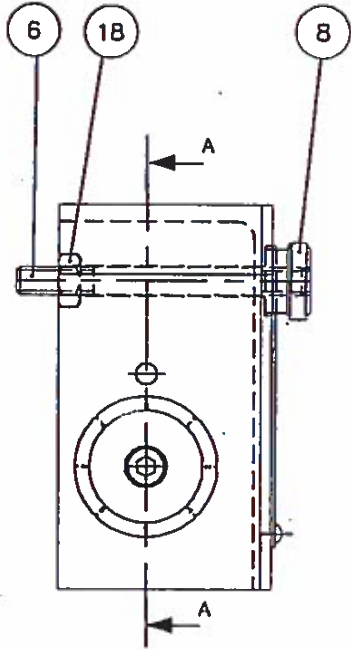

IDLER GEAR SUB ASSEMBLY
(A834 - 0026B)

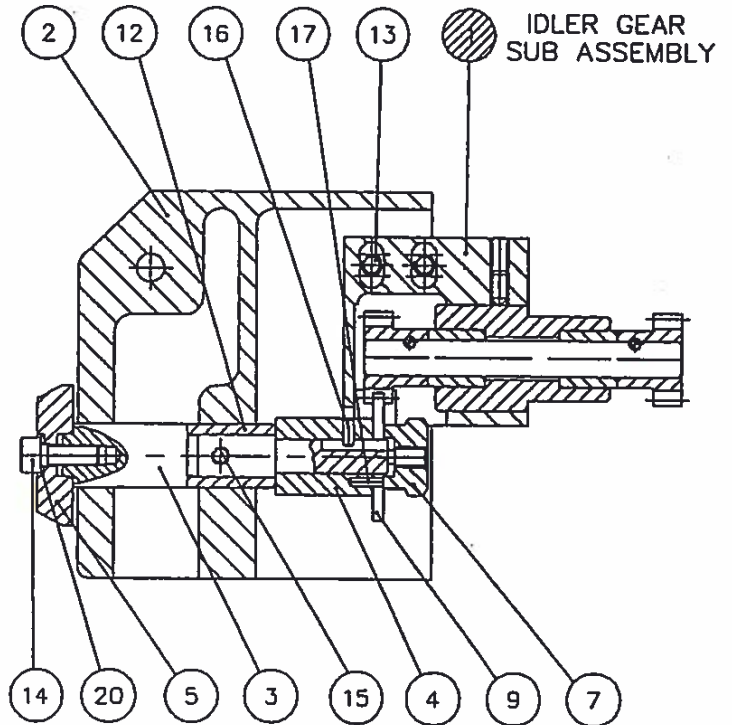

SECTION A-A

IMPERIAL THREAD DIAL INDICATOR ASSEMBLY

A143 - 0605

Item No.	Description	Part No.
1	IDLER GEAR SUB ASSEMBLY	A834 - 0026B
2	HOUSING	D388 - 0141
3	SHAFT	D699 - 0819
4	SPACER	D708 - 0526
5	DIAL	D232 - 0036
6	STUD	D711 - 0205
7	THUMB NUT	D536 - 0335
8	THUMB NUT	D536 - 0336
9	INDICATOR GEAR	D344 - 1323
10	PLATE	D537 - 1115
12	OILITE BUSH CM22x25	B311 - 2022
13	HEXAGON SOCKET CAP HEAD SCREW M6x50	B163 - 0044
14	HEXAGON SOCKET CAP HEAD SCREW M6x12	B163 - 0036
15	HEXAGON SOCKET CONE POINT SET SCREW M5x10	B163 - 1644
16	SPIROL PIN 3 DIA.x8	B111 - 5054
17	SPIROL PIN 3/32"DIA.x5/16"	B111 - 2419
18	NUT M8	B147 - 9153
19	SELF TAPPING SCREW No.4x1/4"	B123 - 2272
20	CRINKLE WASHER M6	B117 - 0107
	IDLER GEAR SUB ASSEMBLY	A834 - 0026B
1	IDLER GEARS SHAFT	D699 - 0818
3	IMPERIAL 12 TOOTH GEAR	D344 - 1322
4	IDLER GEAR HOUSING	D388 - 0142
5	IDLER GEAR SHAFT SLEEVE	D704 - 0135
7	SPIROL PIN 3 DIA.x16	B111 - 5058
8	HEXAGON SOCKET CONE POINT SET SCREW M5x10	B163 - 1644
9	OILITE BUSH CM 20x16	B311 - 2021

HIGH SPEED THREADING UNIT (IMPERIAL)

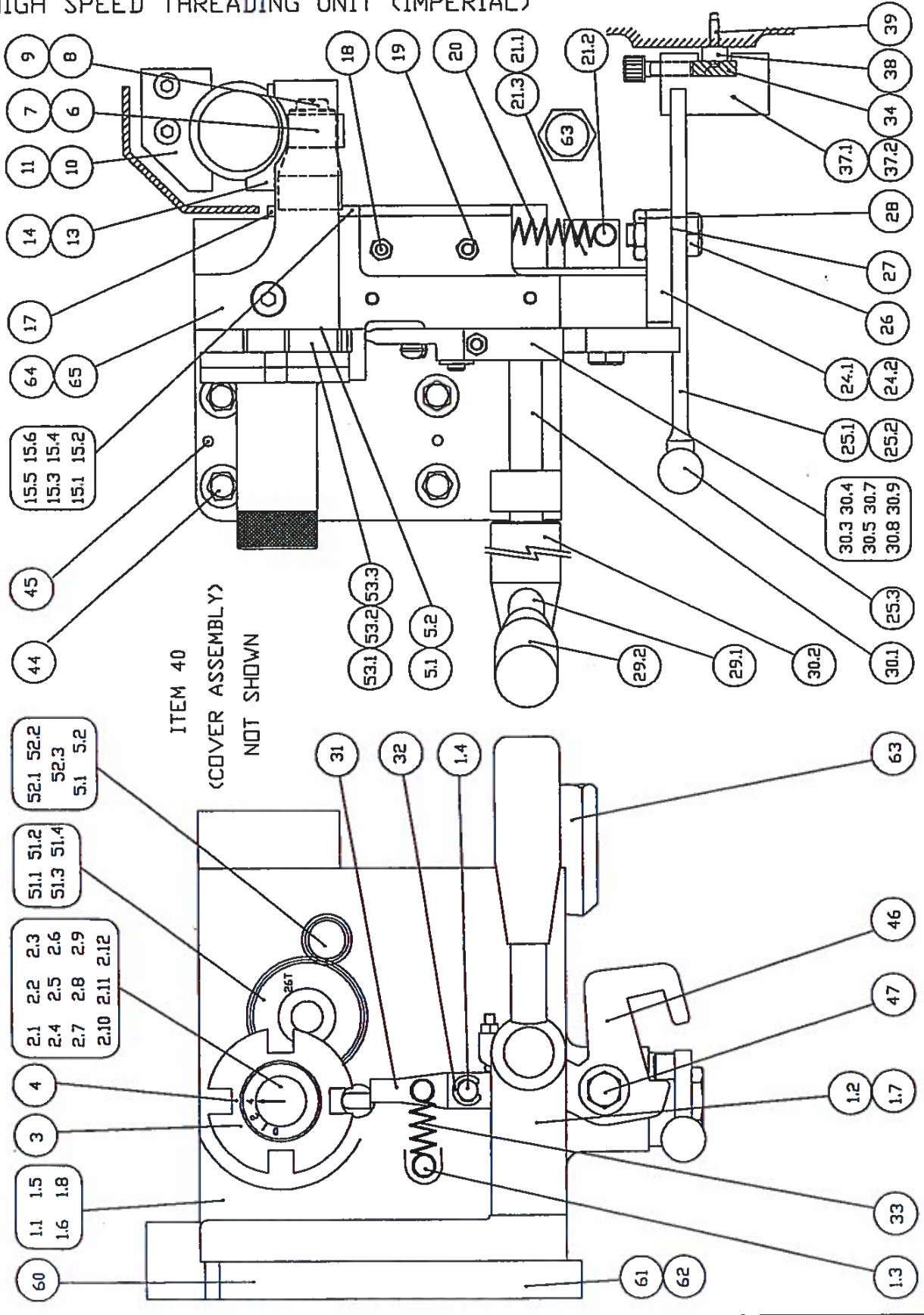

HIGH SPEED THREADING UNIT (IMPERIAL)

0267

Item	Description	Part No.
1	MOUNTING BRACKET ASSEMBLY	
1.1	BRACKET	D01010267
1.2	HANDLE SHAFT BRACKET	D01020021
1.3	LONG ANCHOR SPRING	D01030000
1.4	LOCK LEVER PIVOT	D01040000
1.5	OILITE BEARING CT 51 1/2"idx5/8"odx7/8"	
1.6	OILITE BEARING CT 51 1/2"idx5/8"odx5/8"	
1.7	HEXAGON SOCKET CAP HEAD SCREW 1/4"BSFx7/8"	
1.8	HEXAGON SOCKET SET SCREW M5x12	
2	SETTING DIAL ASSEMBLY	
2.1	SETTING DIAL SHAFT	D02410267
2.2	ENGAGING DIAL	D02020000
2.3	SETTING DIAL	D02030017
2.4	SETTING DIAL PEG	D02040000D
2.5	SETTING DIAL SPRING	D02050000
2.6	DIAL DRIVING GEAR	D54030263
2.7	TAPER PIN 3/16"X11/2"	
2.8	SPIROL PIN 3/32"dia.x3/8"	
2.9	HEXAGON SOCKET C/SUNK SCREW M5x16	
3	BALL BEARING 1 1/8"odx1 1/2"idx1 1/4" long	
4	BEARING SPACER	D04000267
5	PINION SPACER ASSEMBLY	
5.1	PINION SPACER	D05010267
5.2	HEXAGON SOCKET CONE POINT SET SCREW M5x6	
6	PINION	D06600263
7	PIN RETAINING WASHER	D07000000
8	SINGLE COIL SPRING WASHER 5dia.	
9	HEXAGON HEADED SCREW M5x16	
10	STEADY	D10000267
11	HEXAGON SOCKET CAP HEAD SCREW M6x30	
13	HALF NUT	D13000267
14	HEXAGON SOCKET CAP HEAD SCREW M8x60	
15	SLIDE ASSEMBLY	
15.1	SLIDE	D15010267
15.2	ROLLER TRACK ASSEMBLY	D15020267/1&2
15.3	SELECTOR PIN	D15040267
15.4	SHORT ANCHOR SPRING	D01030000S
15.5	HEXAGON SOCKET SET SCREW M6x12	
15.6	SPIROL PIN 3/32"dia.x3/8"	
16	FLAT CAGE NEEDLE ROLLER	INA F2515
17	GIB	D17000267

HIGH SPEED THREADING UNIT (IMPERIAL)

0267

Item	Description	Part No.
18	HEXAGON SOCKET SET SCREW M5x25	
19	THIN HEXAGON LOCK NUT M5	
20	MAIN SPRING	D20000000
21	SPRING CARRIER BLOCK ASSEMBLY	
21.1	SPRING CARRIER BLOCK	D21010015
21.2	SHORT ANCHOR SPRING	D01030000S
21.3	HEXAGON SOCKET CAP HEAD SCREW 1/4"UNCx3/4"	
24	KNOCK-OFF LEVER BRACKET ASSEMBLY	
24.1	KNOCK-OFF LEVER BRACKET	D24400015
24.2	HEXAGON SOCKET CAP HEAD SCREW 1/4"UNCx1/2"	
25	KNOCK-OFF LEVER ASSEMBLY	
25.1	KNOCK-OFF LEVER	D24510015
25.2	KNOCK-OFF LEVER EXTENSION	D24520015
25.3	KNOB 3/4"dia. BLACK PLASTIC	
26	KNOCK-OFF LEVER PIVOT	D25000015
27	FRICTION SPRING 3/8" DOUBLE COIL SPRING WASHER	
28	THIN HEXAGON LOCK NUT 3/8" BSF	
29	HANDLE ASSEMBLY	
29.1	HANDLE	D29000021
29.2	HANDLE KNOB	B382 - 0064
30	HANDLE SHAFT ASSEMBLY	
30.1	HANDLE SHAFT	D30010267
30.2	HANDLE BOSS	D30020267
30.3	ENGAGING LEVER	D30030015
30.4	ENGAGING PIN	D30040000
30.5	LOCK-LEVER CAM	D30050015
30.7	HEXAGON SOCKET SPHERICAL POINT SET SCREW 2BAx1.0"	
30.8	THIN HEXAGON LOCK NUT 2BA	
30.9	TAPER PIN 3/16"x1 1/2"	
31	LOCKING LEVER	D31010019/4
32	CIRCLIP 3/8" ANDERTON TYPE 1500 E303	
33	LOCKING LEVER SPRING	D33000012
34	STOP BAR	D34000267/1-4
37	ADJUSTABLE STOP ASSEMBLY	
37.1	ADJUSTABLE STOP	D37000000
37.2	HEXAGON SOCKET CAP HEAD SCREW M6x16	
38	STOP BAR SPACER	D38000000
39	HEXAGON SOCKET C/SUNK SCREW M6x20	

HIGH SPEED THREADING UNIT (IMPERIAL)

0267

Item No.	Description	Part No.
40	COVER ASSEMBLY	
40.1	COVER	D40010267
40.2	LABEL 110/EX0434/5000-1	
40.3	LABEL 110/EX0434/5000-2	
40.4	ALUMINIUM ROUND HEAD RIVET 1/16"x1/8"	
41	COVER SCREW M5x8 BUTTON HEAD	
44	SECURING SCREW M8x30 CAP HEAD SCREW	
45	DOWEL PIN 'SELOC' 6x30	
46	DISENGAGING LEVER	D46000015
47	DISENGAGING LEVER PIVOT	D47000000
51	IDLER GEAR ASSEMBLY	
51.1	IDLER GEAR	D51020263
51.2	BALL BEARING 1/2"idx 1 1/8"odx1/4"	
51.3	IDLER GEAR SHAFT	D51012263
51.4	HEXAGON SOCKET CAP HEAD SCREW 1/4"UNCx1"	
52	PINION SHAFT ASEMBLY	
52.1	PINION SHAFT GEAR	D52000267
52.2	BEARING	FAG NK12/12
52.3	SPACER	D52030267
60	MOUNTING PLATE	D60000267
61	HEXAGON SOCKET CAP HEAD SCREW M8x16	
62	DOWEL PIN 'SELOC' 6x20	
63	CARRIAGE STOP	D62000267
64	LOWER STEADY	D10040267
65	HEXAGON SOCKET CAP HEAD SCREW M8x30	

HIGH SPEED THREADING UNIT (METRIC)

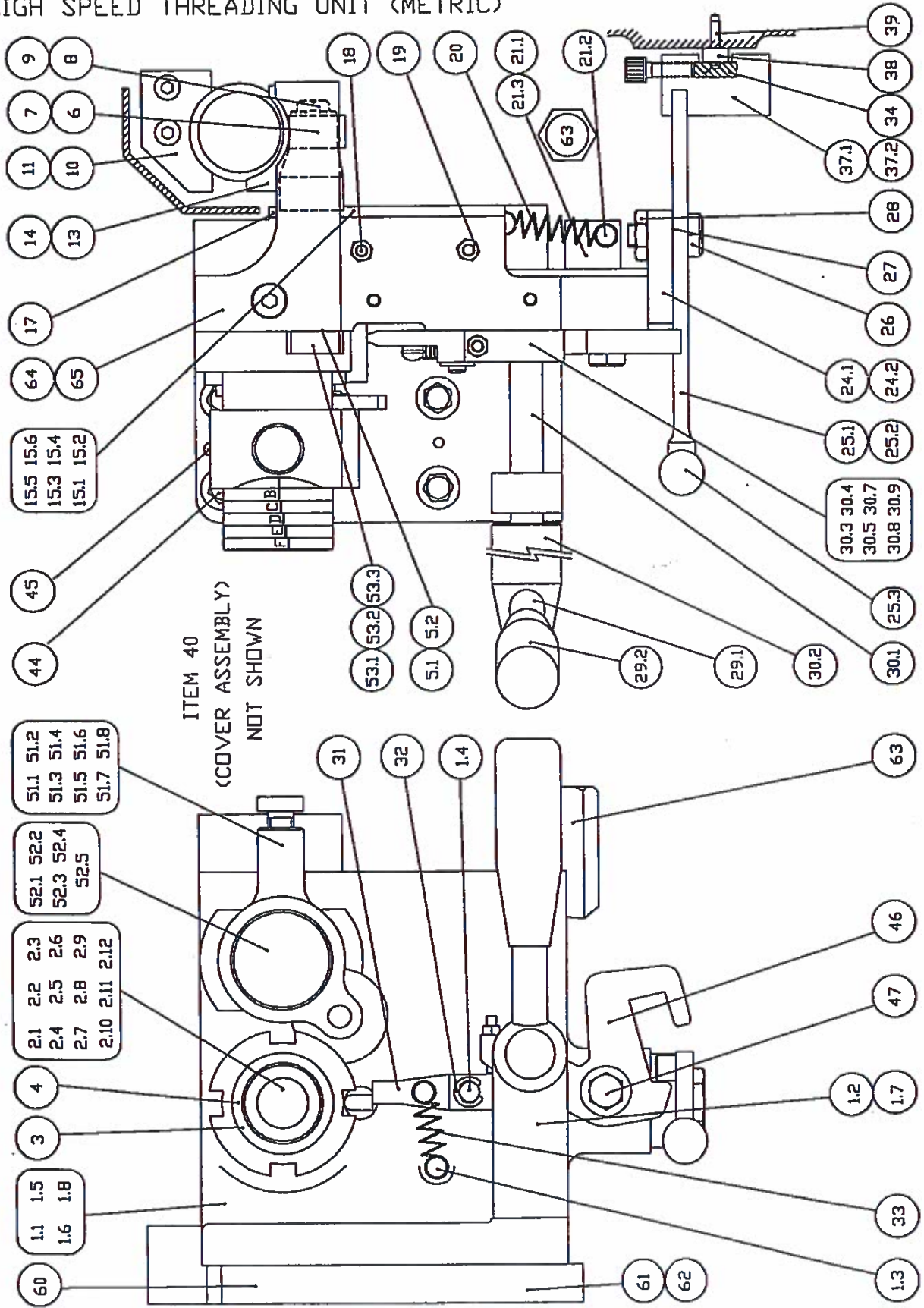

HIGH SPEED THREADING UNIT (METRIC)

0268

Item	Description	Part No.
1	MOUNTING BRACKET ASSEMBLY	
1.1	BRACKET	D01010268
1.2	HANDLE SHAFT BRACKET	D01020021
1.3	LONG ANCHOR SPRING	D01030000
1.4	LOCK LEVER PIVOT	D01040000
1.5	OILITE BEARING CT 51 1/2"idx5/8"odx7/8"	
1.6	OILITE BEARING CT 51 1/2"idx5/8"odx5/8"	
1.7	HEXAGON SOCKET CAP HEAD SCREW 1/4"BSFx7/8"	
1.8	HEXAGON SOCKET SET SCREW M5x12	
2	SETTING DIAL ASSEMBLY	
2.1	SETTING DIAL SHAFT	D02410268
2.2	SETTING DIAL CONTROL	D02421012
2.3	CONE GEARS	D02422022/1-6
2.4	ENGAGING DIAL	D02020022
2.5	SETTING DIAL INDICATOR	D02430012
2.6	SETTING DIAL PEG	D02040000B
2.7	SETTING DIAL SPRING	D02050000
2.8	SETTING DIAL SPRING RETAINING WASHER	D02460012
2.9	SETTING DIAL SHAFT RETAINING WASHER	D07000000
2.10	HEXAGON SOCKET C/SUNK HEAD SCREW M5x16	
2.11	SPIROL PIN 3/32"dia.x3/8"	
3	BALL BEARING 11/8"odx1/2"idx1/4" long	
4	BEARING SPACER	D04000268
5	PINION SPACER ASSEMBLY	
5.1	PINION SPACER	D05010267
5.2	HEXAGON SOCKET CONE POINT SET SCREW M5x6	
6	PINION	D06600264
7	PIN RETAINING WASHER	D07000000
8	HEXAGON HEADED SCREW M5x16	
9	SINGLE COIL SPRING WASHER 5dia.	
10	STEADY	D10000267
11	HEXAGON SOCKET CAP HEAD SCREW M6x30	
13	HALF NUT	D13000268
14	HEXAGON SOCKET CAP HEAD SCREW M8x50	
15	SLIDE ASSEMBLY	
15.1	SLIDE	D15010267
15.2	ROLLER TRACK ASSEMBLY	D15020267/1&2
15.3	SELECTOR PIN	D15040267
15.4	SHORT ANCHOR SPRING	D01030000S
15.5	HEXAGON SOCKET SET SCREW M6x12	
15.6	SPIROL PIN 3/32"dia.x3/8"	
16	FLAT CAGE NEEDLE ROLLER	INA F2515
17	GIB	D17000267

HIGH SPEED THREADING UNIT (METRIC)

0268

Item	Description	Part No.
18	HEXAGON SOCKET SET SCREW M5x25	D20000000
19	THIN HEXAGON LOCK NUT M5	
20	MAIN SPRING	
21	SPRING CARRIER BLOCK ASSEMBLY	D21010015 D01030000S
21.1	SPRING CARRIER BLOCK	
21.2	SHORT ANCHOR SPRING	
21.3	HEXAGON SOCKET CAP HEAD SCREW M5x25	
24	KNOCK-OFF LEVER BRACKET ASSEMBLY	D24400015
24.1	KNOCK-OFF LEVER BRACKET	
24.2	HEXAGON SOCKET CAP HEAD SCREW M5x25	
25	KNOCK-OFF LEVER ASSEMBLY	D24510015 D24520015
25.1	KNOCK-OFF LEVER	
25.2	KNOCK-OFF LEVER EXTENSION	
25.3	KNOB 3/4"dia. BLACK PLASTIC	
26	KNOCK-OFF LEVER PIVOT	D25000015
27	FRICTION SPRING 3/8" DOUBLE COIL SPRING WASHER	
28	THIN HEXAGON LOCK NUT 3/8" BSF	
29	HANDLE ASSEMBLY	D29000021 B382 - 0064
29.1	HANDLE	
29.2	HANDLE KNOB	
30	HANDLE SHAFT ASSEMBLY	D30010267 D30020267 D30030015 D30040000 D30050015
30.1	HANDLE SHAFT	
30.2	HANDLE BOSS	
30.3	ENGAGING LEVER	
30.4	ENGAGING PIN	
30.5	LOCK-LEVER CAM	
30.7	HEXAGON SOCKET SPHERICAL POINT SET SCREW 2BAx1.0"	
30.8	THIN HEXAGON LOCK NUT 2BA	
30.9	TAPER PIN 3/16"x11/2"	
31	LOCKING LEVER	D31010019/4
32	CIRCLIP 3/8"	D33000012
33	LOCKING LEVER SPRING	
34	STOP BAR	D34000267/1-4
37	ADJUSTABLE STOP ASSEMBLY	D37000000
37.1	ADJUSTABLE STOP	
37.2	HEXAGON SOCKET CAP HEAD SCREW M6x16	
38	STOP BAR SPACER	D38000000
39	HEXAGON SOCKET C/SUNK SCREW M6x20	

HIGH SPEED THREADING UNIT (METRIC)

0268

Item	Description	Part No.
40	COVER ASSEMBLY	
40.1	COVER	D40010268
40.2	LABEL 110/EX0434/5000-1	
40.3	LABEL PART OF ABOVE	
40.4	ALUMINIUM ROUND HEAD RIVET 1/16"x1/8"	
41	COVER SCREW M5x8 BUTTON HEAD	
44	SECURING SCREW M8x30 CAP HEAD SCREW	
45	DOWEL PIN 'SELOC' 6x30	D46000015
46	DISENGAGING LEVER	D47000000
47	DISENGAGING LEVER PIVOT	
51	GEAR SELECTOR ASSEMBLY	
51.1	IDLER GEAR CARRIER	D51011268
51.2	IDLER GEAR	D51010012
51.3	OILITE BEARING 1/2'odx3/8"idx3/16"	
51.4	IDLER GEAR SHAFT	D51012020
51.5	CIRCLIP 3/8 "(ANDERTON 1500E303)	
51.6	SPIROL PIN 3/32"x3/4"	
51.7	SELECTOR SCREW	D51050020
51.8	STOP SCREW 2Bax5/16"	
52	GATE ASSEMBLY	
52.1	GATE	D54010268
52.2	GATE ASSEMBLY GEAR	D54020268
52.3	BALL RACE 11/8'odx1/2"idx1/4"	
52.4	BEARING	FAG NKJ 9/12
52.5	HEXAGON SOCKET CAP HEAD SCREW M6x20	
53	PINION SHAFT ASSEMBLY	
53.1	PINION SHAFT GEAR	D52000268
53.2	BEARING	FAG NK12/12
53.3	SPACER	D52030268
60	MOUNTING PLATE	D60000267
61	HEXAGON SOCKET CAP HEAD SCREW M8x16	
62	DOWEL PIN 'SELOC' 6x20	
63	CARRIAGE STOP	D62000267
64	LOWER STEADY	D10040267
65	HEXAGON SOCKET CAP HEAD SCREW M8x30	

HEIDENHAIN DRO KITS

Item No.	Description	Part No.
	HEIDENHAIN 2 AXIS DRO KIT A830 - 0031	
1	HEIDENHAIN CONTROL VRZ 730 2 AXIS	B770 - 0104
2	1.0m 2 AXIS GLASS DRO	A830 - 0029A
3	1.5m 2 AXIS GLASS DRO	A830 - 0029B
4	2.0m 2 AXIS GLASS DRO	A830 - 0029C
5	3.0m 2 AXIS GLASS DRO	A830 - 0029D
10	HEIDENHAIN CONTROL VRZ 739 2 AXIS + CSS	B770 - 0137
11	1.0m 2 AXIS MAGNETIC DRO	A830 - 0018A
12	1.5m 2 AXIS MAGNETIC DRO	A830 - 0018B
13	2.0m 2 AXIS MAGNETIC DRO	A830 - 0018C
14	3.0m 2 AXIS MAGNETIC DRO	A830 - 0018D
	HEIDENHAIN 3 AXIS KIT A830 - 0032	
1	HEIDENHAIN CONTROL VRZ 770 3 AXIS	B770 - 0129
2	3RD AXIS GLASS DRO KIT	B770 - 0406
4	1.0m 2 AXIS GLASS DRO	A830 - 0029A
5	1.5m 2 AXIS GLASS DRO	A830 - 0029B
6	2.0m 2 AXIS GLASS DRO	A830 - 0029C
7	3.0m 2 AXIS GLASS DRO	A830 - 0029D
10	HEIDENHAIN CONTROL VRZ 779 3 AXIS + CSS	B770 - 0138
11	3RD AXIS MAGNETIC DRO	A830 - 0022A
12	1.0m 2 AXIS MAGNETIC DRO	A830 - 0018A
13	1.5m 2 AXIS MAGNETIC DRO	A830 - 0018B
14	2.0m 2 AXIS MAGNETIC DRO	A830 - 0018C
15	3.0m 2 AXIS MAGNETIC DRO	A830 - 0018D
	HEIDENHAIN 2AXIS + CSS KIT A830 - 0033	
1	HEIDENHAIN CONTROL VRZ 739 2 AXIS + CSS	B770 - 0137
2	CSS RETRO KIT	A864 - 0028A
4	1.0m 2 AXIS GLASS DRO	A830 - 0029A
5	1.5m 2 AXIS GLASS DRO	A830 - 0029B
6	2.0m 2 AXIS GLASS DRO	A830 - 0029C
7	3.0m 2 AXIS GLASS DRO	A830 - 0029D
10	HEIDENHAIN CONTROL VRZ 739 2 AXIS + CSS	B770 - 0137
11	1.0m 2 AXIS MAGNETIC DRO	A830 - 0018A
12	1.5m 2 AXIS MAGNETIC DRO	A830 - 0018B
13	2.0m 2 AXIS MAGNETIC DRO	A830 - 0018C
14	3.0m 2 AXIS MAGNETIC DRO	A830 - 0018D
	HEIDENHAIN 3 AXIS + CSS KIT A830 - 0034	
1	HEIDENHAIN CONTROL VRZ 779 3 AXIS + CSS	B770 - 0138
2	CSS RETRO KIT	A864 - 0028A
3	3RD AXIS GLASS DRO KIT	B770 - 0406
5	1.0m 2 AXIS GLASS DRO	A830 - 0029A
6	1.5m 2 AXIS GLASS DRO	A830 - 0029B
7	2.0m 2 AXIS GLASS DRO	A830 - 0029C
8	3.0m 2 AXIS GLASS DRO	A830 - 0029D
10	HEIDENHAIN CONTROL VRZ 779 3 AXIS + CSS	B770 - 0138
11	3RD AXIS MAGNETIC DRO KIT	A830 - 0022A
12	1.0m 2 AXIS MAGNETIC DRO	A830 - 0018A
13	1.5m 2 AXIS MAGNETIC DRO	A830 - 0018B
14	2.0m 2 AXIS MAGNETIC DRO	A830 - 0018C
15	3.0m 2 AXIS MAGNETIC DRO	A830 - 0018D

HEIDENHAIN MAGNETIC SCALE PACKS

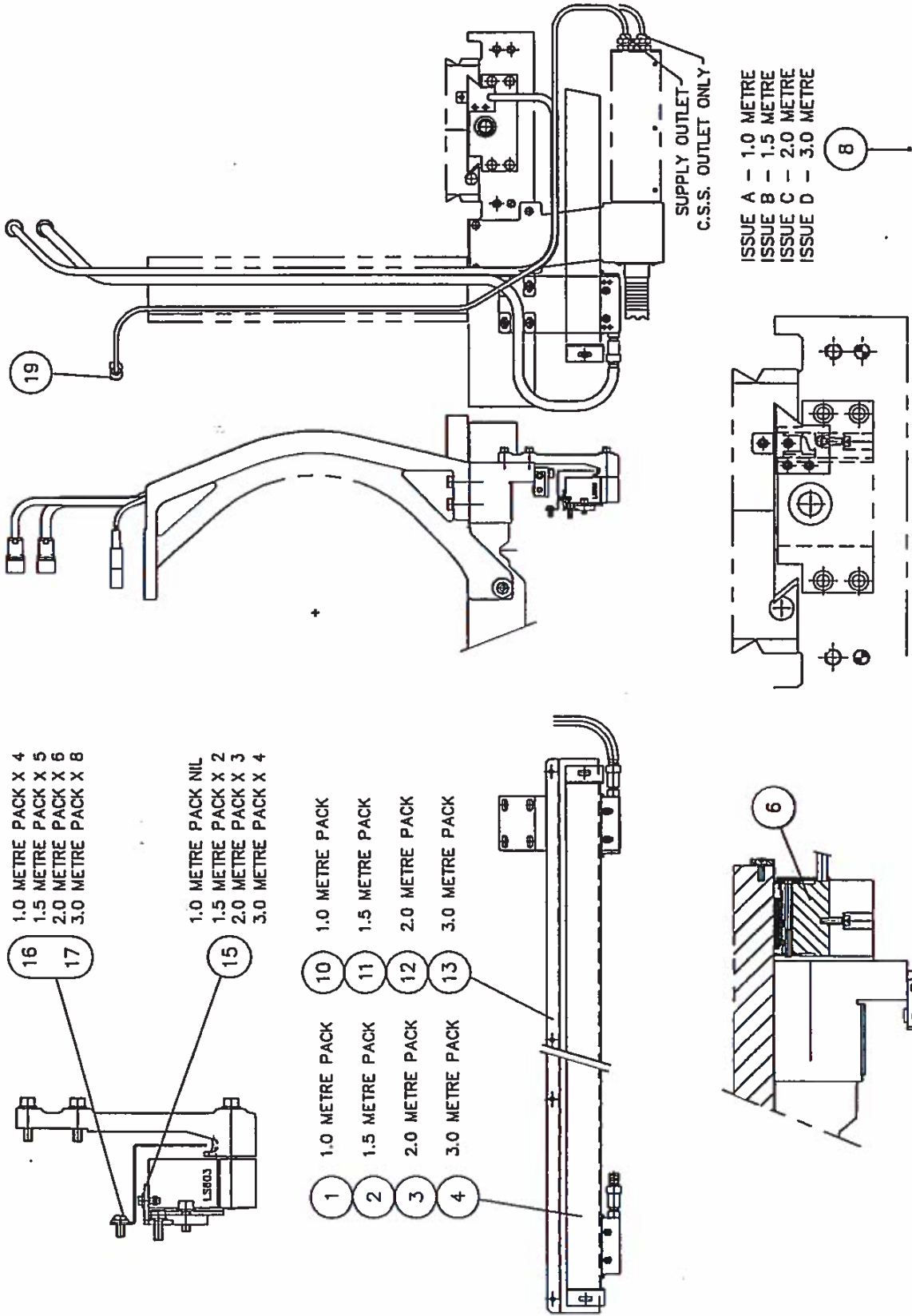

ISSUE A - 1.0 METRE
 ISSUE B - 1.5 METRE
 ISSUE C - 2.0 METRE
 ISSUE D - 3.0 METRE

FOR HEIDENHAIN FITTINGS KIT
 SEE A830-0014

HEIDENHAIN MAGNETIC SCALE PACK

A830 - 0011

Item No.	Description	Part No.
1	DRO SCALE LS603C-1020	B770 - 0139
2	DRO SCALE LS603C-1540	B770 - 0140
3	DRO SCALE LS603C-2040	B770 - 0141
4	DRO SCALE LS603C-3040	B770 - 0142
6	X AXIS HEIDENHAIN MAGNETIC SCALE KIT	B770 - 0403
8	HEIDENHAIN DTO FIXING KIT	A830 - 0014A
10	X AXIS DRO COVER 1.0m	B770 - 0143
11	X AXIS DRO COVER 1.5m	B770 - 0144
12	X AXIS DRO COVER 2.0m	B770 - 0145
13	X AXIS DRO COVER 3.0m	B770 - 0146
15	Z AXIS SUPPORT BRACKET	B770 - 0147
16	HEXAGON SOCKET BUTTON HEAD SCREW M6x10	B163 - 1813
17	M6 WASHER	B117 - 0009
19	MAINS CABLE	B770 - 0148

HEIDENHAIN DRO BRACKET FIXING KIT

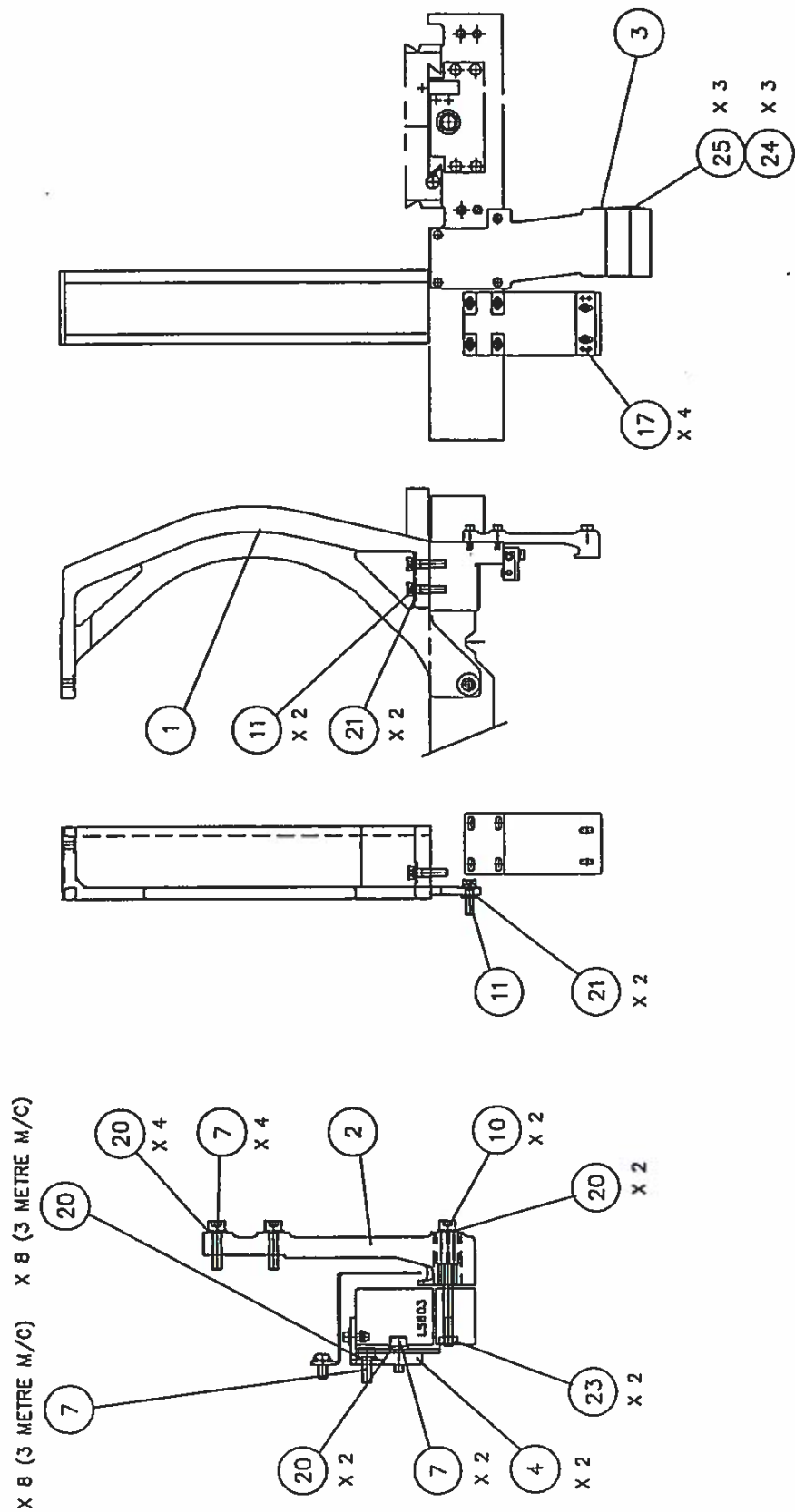

DRO BRACKET KIT

A830 - 0015

Item No.	Description	Part No.
1	DRO COUNTER HEAD BRACKET	D050 - 0757
2	Z AXIS SCALE BRACKET	D050 - 0758
4	SPACER	D708 - 0528
7	HEXAGON SOCKET CAP HEAD SCREW M6x 16	B163- 0037
10	HEXAGON SOCKET CAP HEAD SCREW M6x75	B163Y0049
11	HEXAGON SOCKET CAP HEAD SCREW M10x 40	B163- 0071
17	HEXAGON SOCKET SET SCREW M4x 20	B163- 1727
20	M6 WASHER	B117 - 0009
21	M10 WASHER	B117Y0011
23	M6x1.0 THIN NUT	B147 - 9169

HEIDENHAIN DRO ASSEMBLY (MAGNETIC) X & Z AXIS

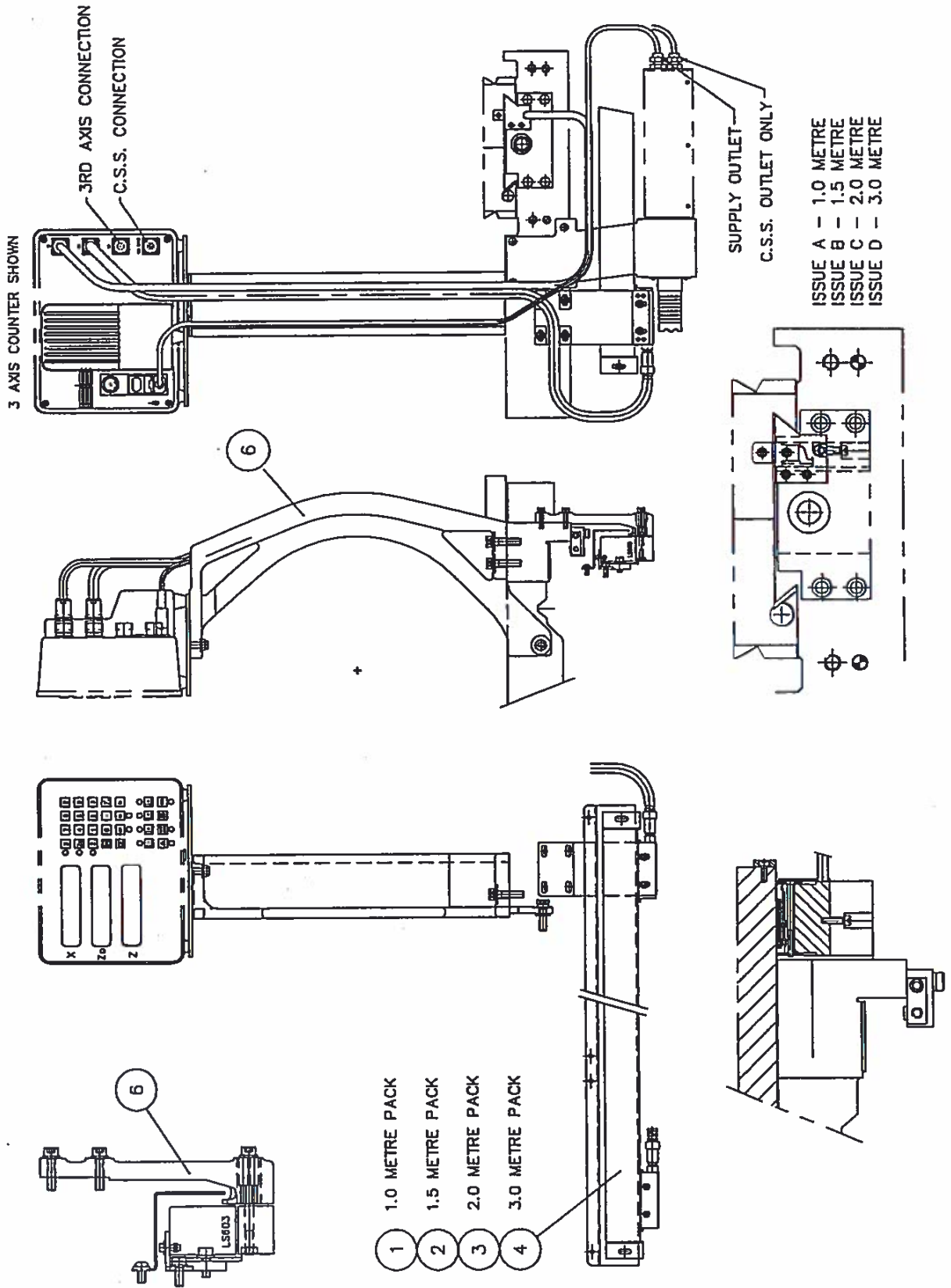

HEIDENHAIN DRO KIT (MAGNETIC)

A830 - 0018

Item No.	Description	Part No.
1	1.0m MAGNETIC SCALE PACK	A830 - 0011A
2	1.5m MAGNETIC SCALE PACK	A830 - 0011B
3	2.0m MAGNETIC SCALE PACK	A830 - 0011C
4	3.0m MAGNETIC SCALE PACK	A830 - 0011D
6	DRO BRACKET KIT	A830 - 0015A

HEIDENHAIN 3RD AXIS MAGNETIC SCALE KIT

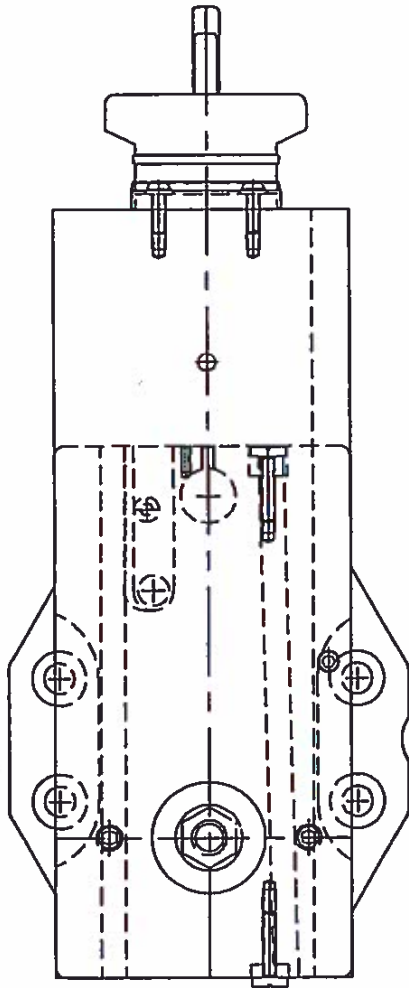

VIEW WITH KEEP & SCREW REMOVED

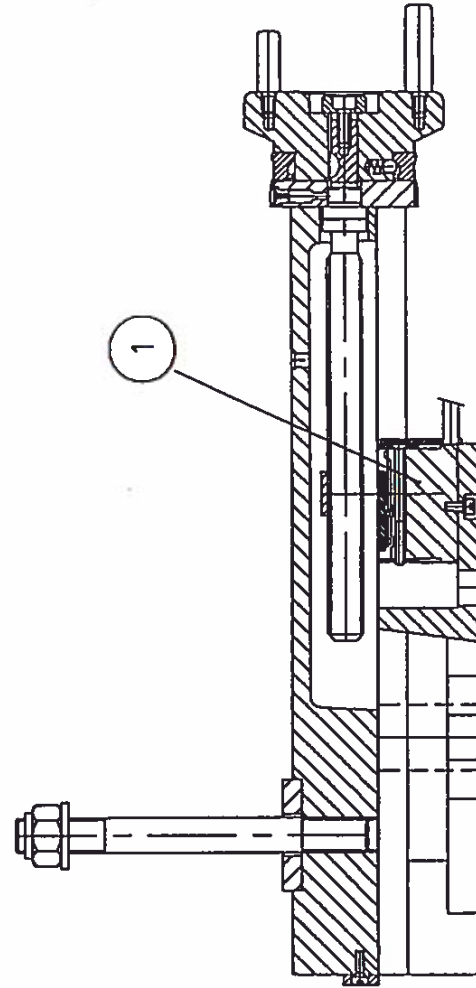
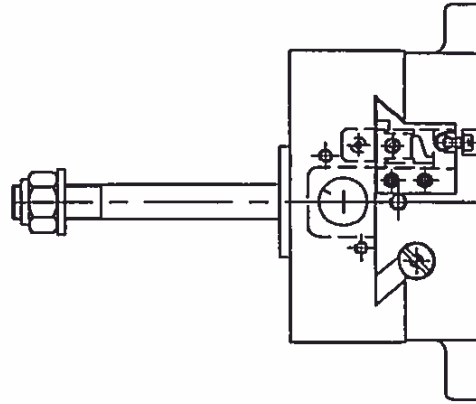

HEIDENHAIN 3RD AXIS MAGNETIC SCALE KIT

A830 - 0022

Item No.	Description	Part No.
1	3RD AXIS DRO MAGNETIC SCALE	B770 - 0404

HEIDENHAIN DRO ASSEMBLY (GLASS) X & Z AXIS

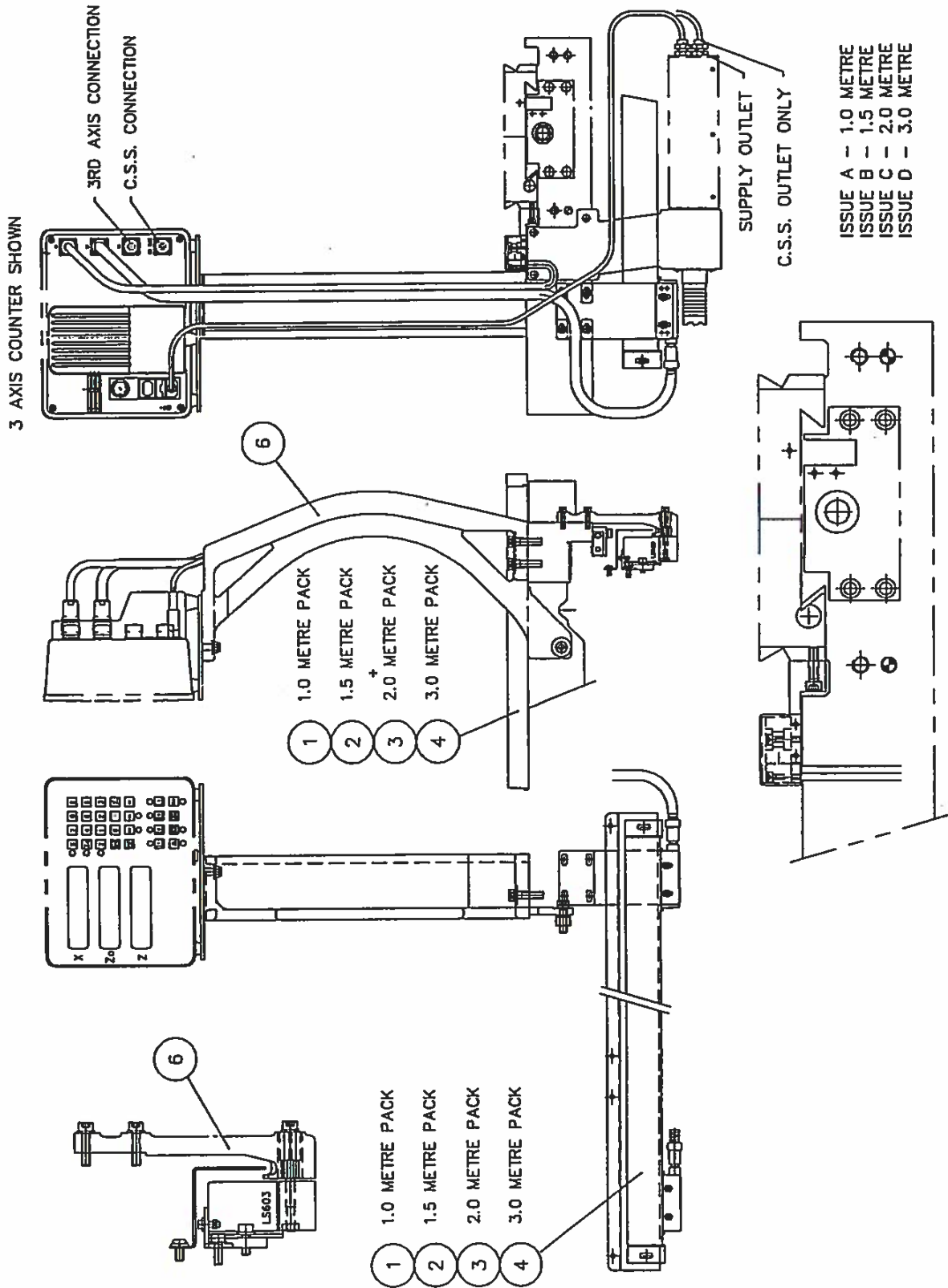

HEIDENHAIN DRO ASSEMBLY (GLASS)

A830 - 0029

Item No.	Description	Part No.
1	1.0m GLASS SCALE PACK	A830 - 0030A
2	1.5m GLASS SCALE PACK	A830 - 0030B
3	2.0m GLASS SCALE PACK	A830 - 0030C
4	3.0m GLASS SCALE PACK	A830 - 0030D
6	DRO BRACKET KIT	A830 - 0015A

HEIDENHAIN GLASS SCALE PACKS

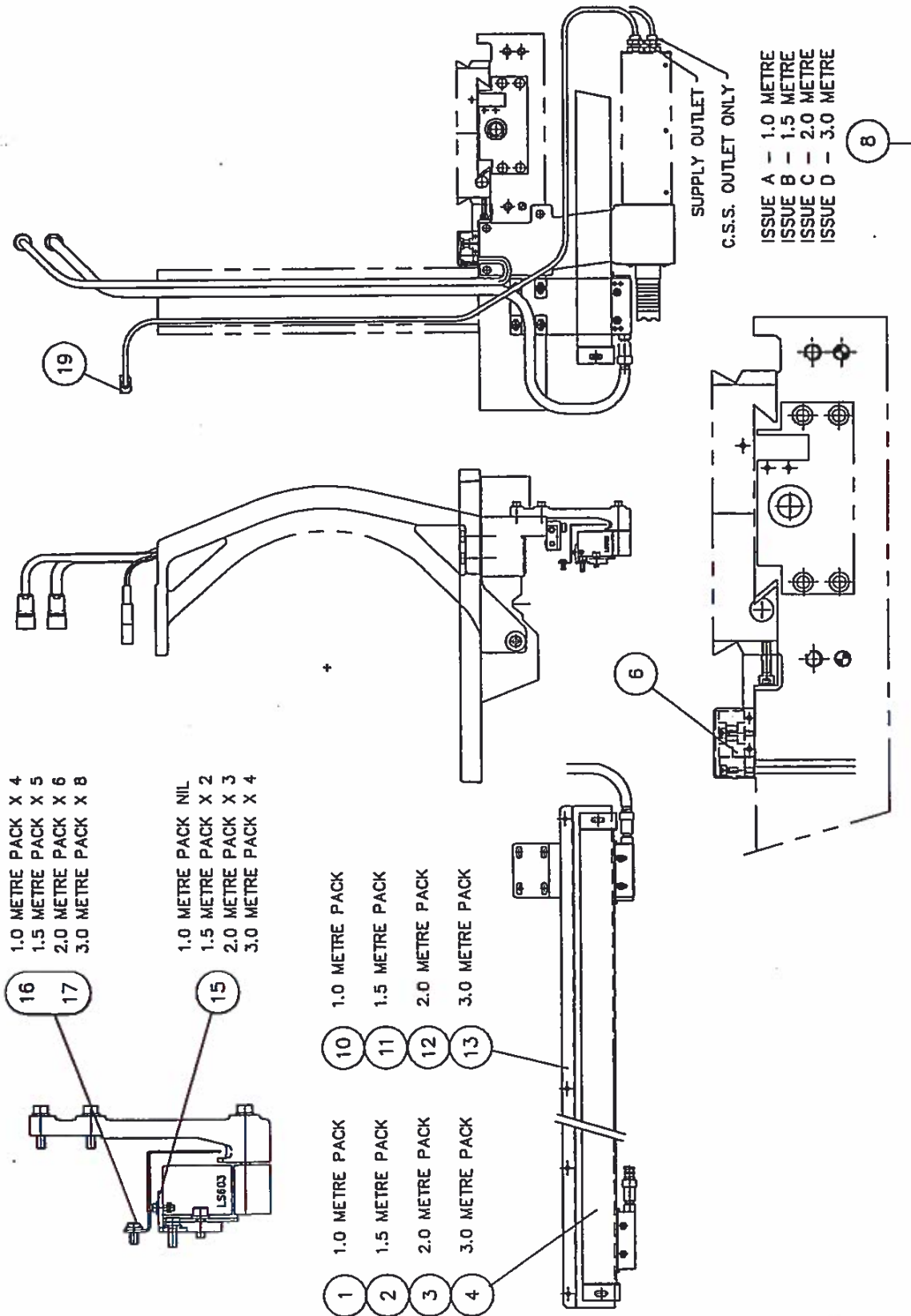

HEIDENHAIN GLASS SCALE PACK

A830 - 0030

Item No.	Description	Part No.
1	DRO SCALE LS603C-1020	B770 - 0139
2	DRO SCALE LS603C-1540	B770 - 0140
3	DRO SCALE LS603C-2040	B770 - 0141
4	DRO SCALE LS603C-3040	B770 - 0142
6	X AXIS HEIDENHAIN GLASS SCALE KIT	B770 - 0405
8	HEIDENHAIN DRO FIXING KIT	A830 - 0014A
10	X AXIS DRO COVER 1.0m	B770 - 0143
11	X AXIS DRO COVER 1.5m	B770 - 0144
12	X AXIS DRO COVER 2.0m	B770 - 0145
13	X AXIS DRO COVER 3.0m	B770 - 0146
15	Z AXIS SUPPORT BRACKET	B770 - 0147
16	HEXAGON SOCKET BUTTON HEAD SCREW M6x10	B163 - 1813
17	M6 WASHER	B117 - 0009
19	MAINS CABLE	B770 - 0148

MASTIFF PARTS

INDEX

ITEM

1. Headstock Assembly
2. Reversing Box Assembly
7. Top Slide Assembly
8. Tailstock Assembly
14. Belts and Pulleys
20. Nameplates
22. Sheet Metal Pack
23. Standard Equipment

MASTIFF ACCESSORIES

HEADSTOCK

HEADSTOCK ASSEMBLY (1)

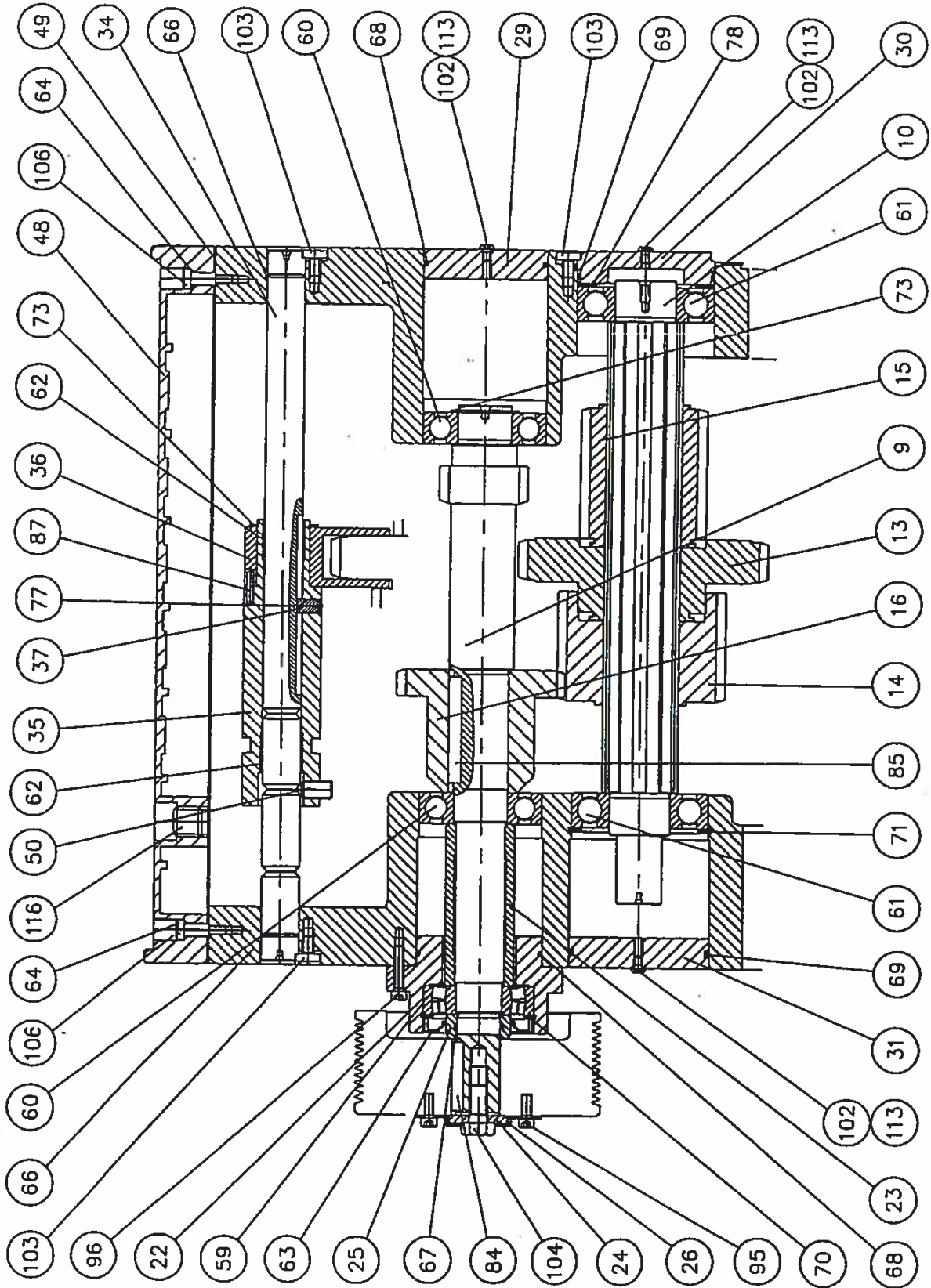

HEADSTOCK ASSEMBLY

A100 - 0609B

Item No.	Description	Part No.
2	HEADSTOCK CASTING	D384 - 0061
4	MAIN SPINDLE	D709 - 0053
9	INPUT SHAFT	D699 - 0804
10	SPLINE SHAFT	D699 - 0805
11	101T GEAR	D344 - 1291
12	69T GEAR	D344 - 1292
13	63T GEAR	D344 - 1293
14	42T GEAR	D344 - 1294
15	31T GEAR	D344 - 1295
16	42T GEAR	D344 - 1296
17	FRONT BEARING COVER	D132 - 0799
18	BACK BEARING OUTER COVER	D132 - 0800
19	BACK BEARING INNER COVER	D132 - 0809
20	FRONT BEARING COVER GASKET	D343 - 0186
21	BACK BEARING COVER GASKET	D343 - 0187
22	INPUT SHAFT HOUSING	D388 - 0138
23	INPUT SHAFT BEARING SPACER	D708 - 0512
24	HEADSTOCK PULLEY SPACER	D708 - 0464
25	HEADSTOCK PULLEY SPACER	D708 - 0462
26	HEADSTOCK PULLEY TAB WASHER	D931 - 0342
27	FRONT BEARING NUT	D536 - 0328
28	BACK BEARING NUT	D536 - 0330
29	INPUT SHAFT PLUG	D566 - 0198
30	SPLINE SHAFT PLUG	D566 - 0199
31	SPLINE SHAFT PLUG	D566 - 0200
33	COOLANT THROWER	D646 - 0059
34	BAR-SHIFT SUPPORT	D041 - 0247
35	SHIFTER TUBE	D834 - 0040
36	GEAR SHIFTER FORK	D299 - 0073
37	KEY-SHIFTER TUBE	D441 - 0076
38	GEAR SHIFT BLOCK	D047 - 0130
39	GEAR SHIFT SHAFT	D699 - 0810
40	SHIFTER FORK	D299 - 0068
41	COTTER PIN	D560 - 0288
42	SET OVER PAD	D557 - 0154
43	SET OVER PIN	D560 - 0297
45	SPINDLE NOSE CAM	D123 - 0072
47	CAM SCREW	D697 - 0206
48	HEADSTOCK COVER	D132 - 0805
49	HEADSTOCK COVER GASKET	D343 - 0185
50	ESLOK SPRING PLUNGER	D567 - 0058
57	FRONT BEARING (SPECIAL GAMET BASED ON 164.133X/164.196XHS)	B336 - 1787
58	REAR BEARING (SPECIAL GAMET BASED ON 105.115X/105.165)	B336 - 1353
59	ROLLER BEARING (SKF 21306CC)	B325 - 7501
60	FAG BEARING 6307	B313 - 2417
61	FAG BEARING 6308	B313 - 2420

HEADSTOCK ASSEMBLY (2)

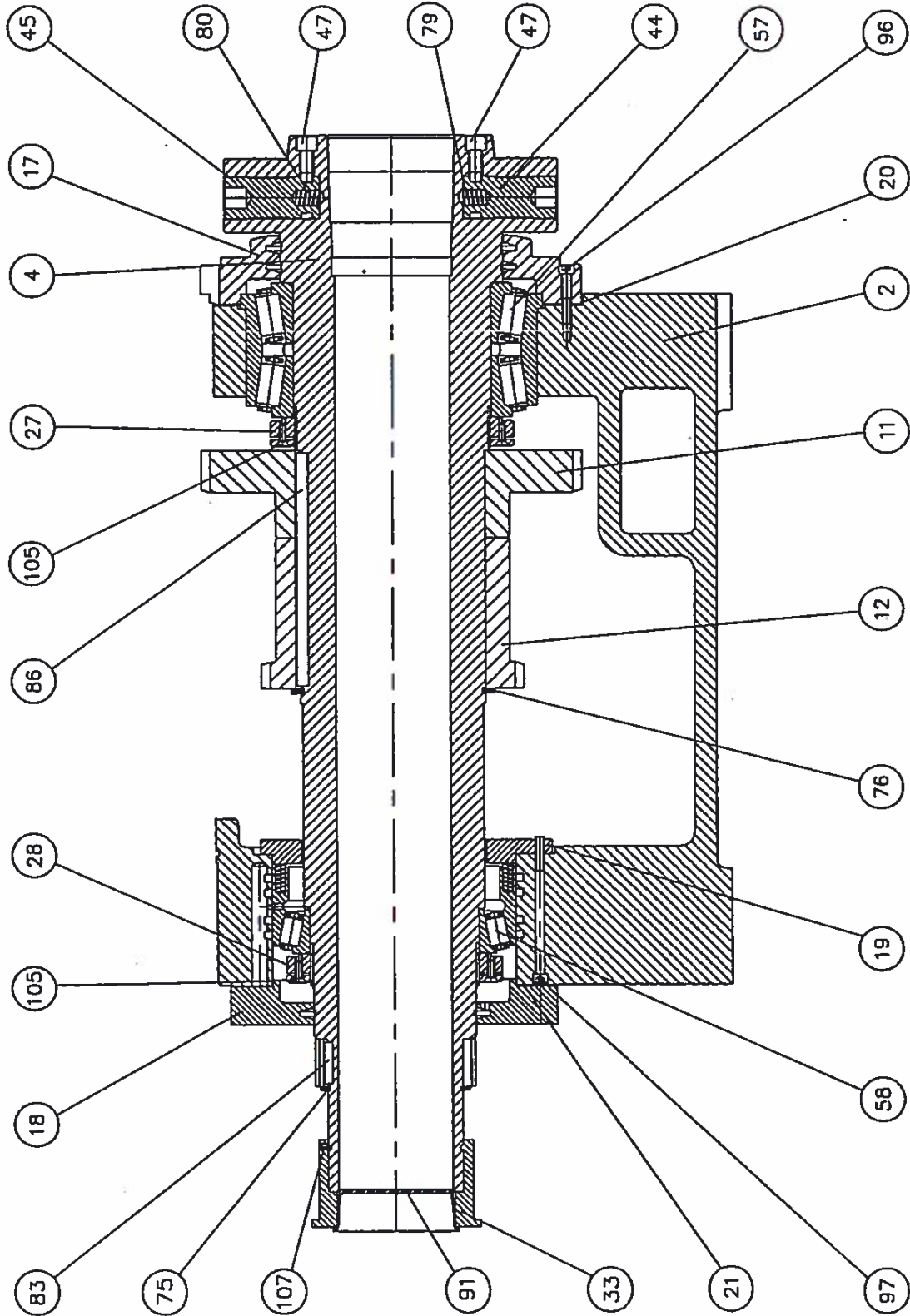

HEADSTOCK ASSEMBLY

A100 - 0609B

Item No.	Description	Part No.
62	GLACIER BUSH MB2525DU	B311 - 1564
63	OIL SEAL M42X72x8-42	B414 - 3221
64	O RING 200/011/4460	B412 - 0011
65	O RING DOWTY REF 202-518	B413 - 0161
66	O RING DOWTY REF 202-524	B413 - 0221
67	O RING DOWTY REF 202-649	B413 - 0276
68	O RING DOWTY REF 202-740	B413 - 0745
69	O RING DOWTY REF 202-742	B413Y0800
70	CIRCLIP ANDERTON 1300-72	B363 - 0472
71	CIRCLIP ANDERTON 1300-90	B363 - 0490
72	CIRCLIP ANDERTON 1400-19	B363 - 0019
73	CIRCLIP ANDERTON 1400-35	B363 - 0035
75	CIRCLIP ANDERTON 1400-110	B363 - 0110
76	CIRCLIP ANDERTON 1400-125	B363 - 0125
77	PLAIN WIRE RING 1000-200	B362 - 1027
78	SCHNORR DISC SPRING 6308	B365 - 6432
80	SPRING FLEXO REF123308	B365 - 1177
81	OIL SIGHT SK 1185 C4610	B454 - 1002
82	OIL SIGHT IC 4611	B454 - 1001
83	KEY 6x6x28	B343 - 5049
84	KEY 8x7x45	B343Y5108
85	KEY 10x8x70	B343 - 5117
86	SPINDLE KEY	D441 - 0083
87	SPIROL PIN 4x20	B111 - 5076
88	SPIROL PIN 10x40	B111 - 5160
89	DOWEL 12x36	B111Y7093
91	PLASTIC PLUG MOSS 10253	B224 - 2311
95	HEXAGON SOCKET CAP HEAD SCREW M6x16	B163 - 0037
96	HEXAGON SOCKET CAP HEAD SCREW M6x30	B163 - 0040
97	HEXAGON SOCKET CAP HEAD SCREW M8x95	B163 - 0151
99	HEXAGON SOCKET CAP HEAD SCREW M8x30	B163 - 0055
100	HEXAGON SOCKET CAP HEAD SCREW M10x40	B163 - 0071
101	HEXAGON SOCKET CAP HEAD SCREW M16x50	B163 - 0102
102	HEXAGON SOCKET BUTTON HEAD SCREW M6x10	B163 - 1813
103	SLOTTED PAN HEAD SCREW M8x12	B165 - 0147
104	HEXAGON HEAD SCREW M12x25	B166 - 0097
105	HEXAGON SOCKET C/SK SCREW M5x16	B163 - 1016
106	SHOULDER SCREW M8x16	B163 - 1856
107	SET SCREW M5x6	B163 - 1642
108	WEDGLOK SET SCREW M12x20	B164 - 0170
110	NYLOC NUT M5	B147 - 9002
112	WASHER M5	B117 - 0032
113	FIBRE WASHER 110Dx6 ID	B117 - 0151
115	HEXAGON SOCKET PLUG 1/8" BSPT	B424 - 3200
116	HEXAGON SOCKET PLUG 1/2" BSPT	B424 - 3210

HEADSTOCK ASSEMBLY (3)

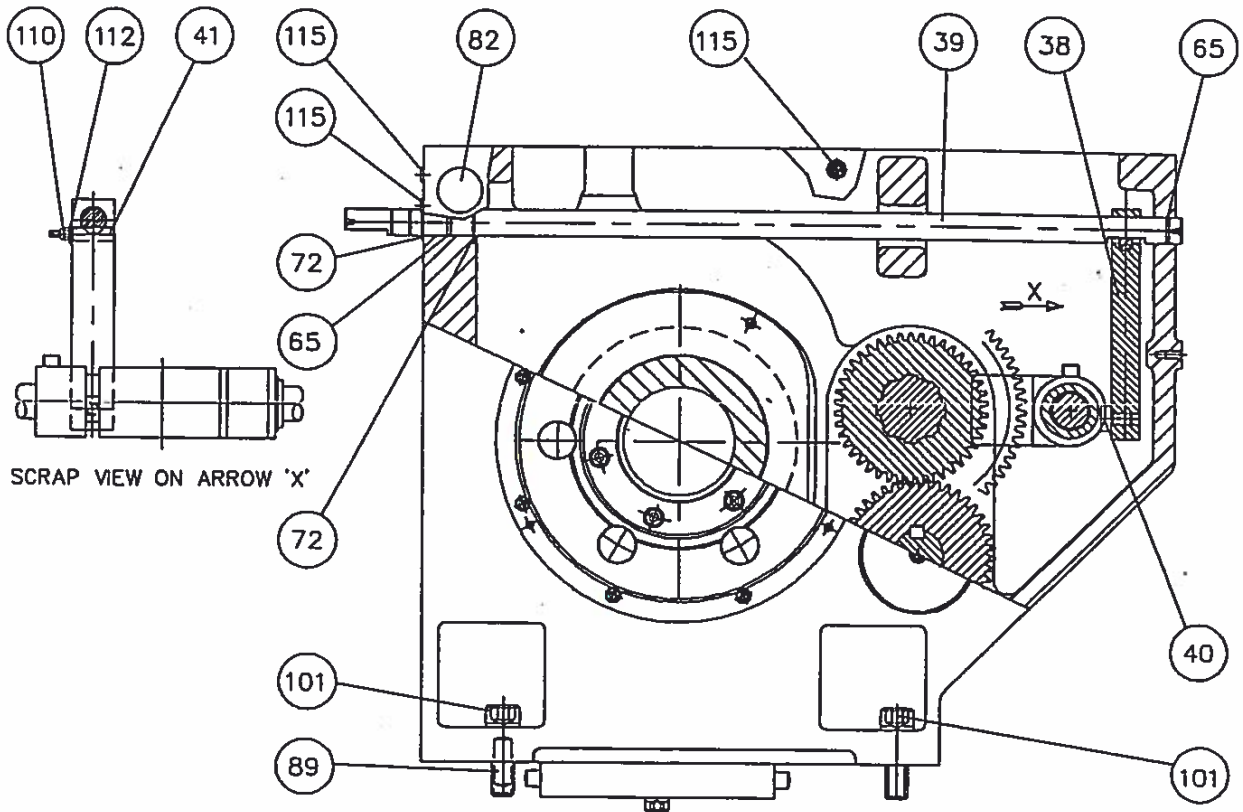

SCRAP VIEW ON ARROW 'X'

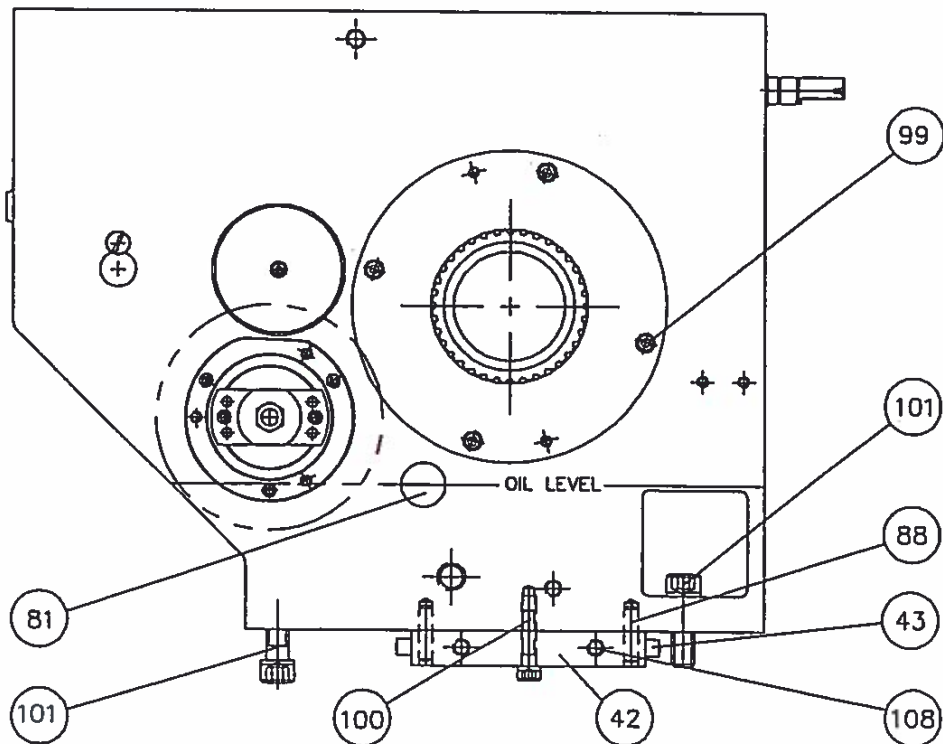

REVERSING BOX ASSEMBLY (1)

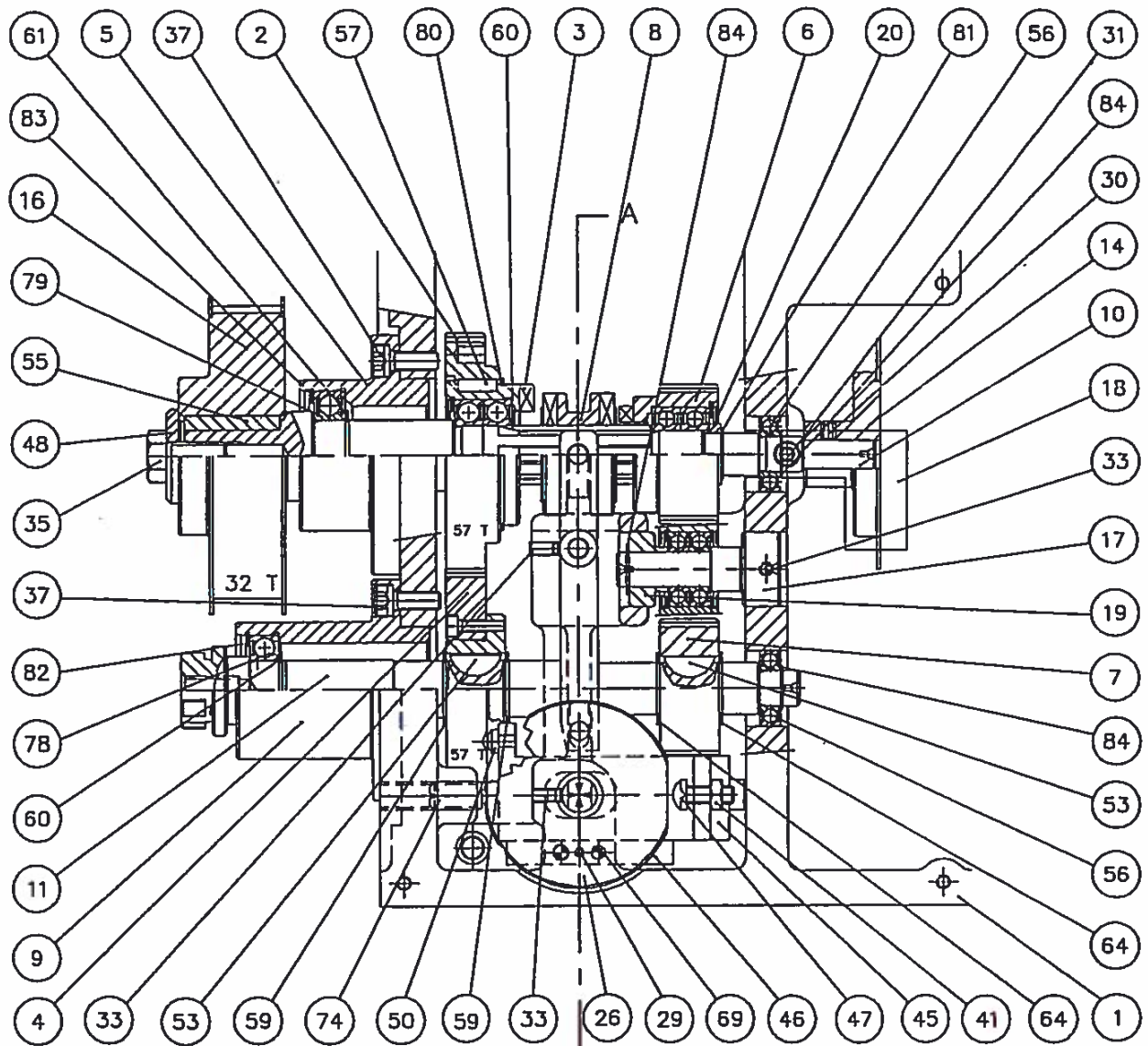

SCRAP SECTION
SHOWING
IDLER GEAR

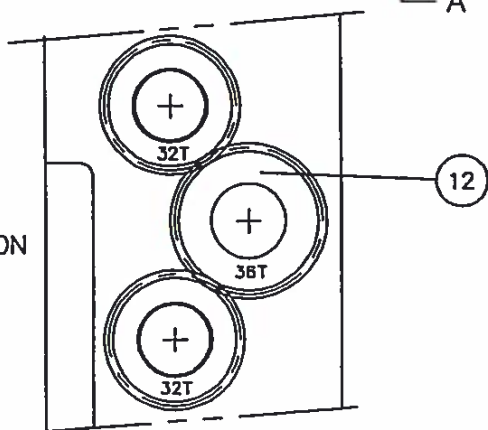

SECTION THROUGH BLOCK (ITEM 45)

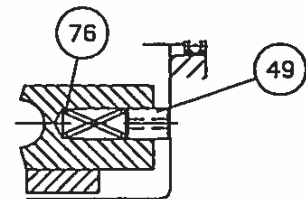

REVERSING BOX ASSEMBLY

A109 - 0002

Item No.	Description	Part No.
1	REVERSING BOX	D053 - 0085
2	GEAR	D344 - 1257
3	SPACER SUB-ASSEMBLY	A806 - 0558
4	GEAR SUB-ASSEMBLY	A806 - 0560
5	INPUT SHAFT HOUSING	D388 - 0123
6	32T GEAR SUB-ASSEMBLY	A806 - 0576
7	32T GEAR	D344 - 1317
8	CLUTCH BOBBIN	D051 - 0006
9	OUTPUT SHAFT HOUSING	D388 - 0124
10	INPUT SHAFT	D699 - 0777
11	OUTPUT SHAFT	D699 - 0778
12	36T GEAR SUB-ASSEMBLY	A806 - 0577
14	SENSOR MOUNTING SPIGOT SUB-ASSEMBLY	A806 - 0561
16	32T PULLEY SUB-ASSEMBLY	A824 - 0036
17	IDLER SHAFT	D699 - 0816
18	SENSOR MOUNTING BRACKET	D050 - 0677
19	IDLER SHAFT SPACER	D708 - 0521
20	INPUT SHAFT SPACER	D708 - 0459
21	PLUG	D566 - 0202
22	SHIFTER PAD	D299 - 0067
23	SHIFTER BAR	D041 - 0230
24	SHIFTER PIVOT SHAFT	D699 - 0779
25	REVERSE LEVER SHAFT	D699 - 0781
26	SHIFTER DISC	D233 - 0023
27	SHIFTER PIN	D560 - 0295
29	HEXAGON SOCKET CAP HEAD SCREW M4x20	B163Y0017
30	HEXAGON SOCKET SET SCREW M6x6	B163 - 1560
31	HEXAGON SOCKET CAP HEAD SCREW M6x12	B163 - 0036
32	HEXAGON SOCKETSET SCREW M12x16	B163 - 1781
33	HEXAGON SOCKETSET SCREW M6x8	B163 - 1740
35	HEXAGON SOCKET CAP HEAD SCREW M4x20	B163Y0017
37	HEXAGON SOCKET CAP HEAD SCREW M8x20	B163 - 0053
38	HEXAGON SOCKET CAP HEAD SCREW M4x10	B163Y0014
39	HEXAGON SOCKET CAP HEAD SCREW M8x25	B163 - 0054
41	LOCK NUT M6	B147 - 9170
45	BLOCK	D047 - 0104
46	BLOCK	D047 - 0105
48	INPUT PULLEY SPACER	D708 - 0468
49	PIN	D560 - 0303
50	PIN	D560 - 0304
53	WOODRUFF KEY 6x9x22	B343 - 2009
54	KEY 6x6x10	B343 - 5041
55	KEY 8x7x40	B343 - 5107
56	BALL BEARING 6002 2Z	B315 - 0410
57	KEY (ROUNDED ENDS) 5x5x16	B343 - 5031

RANGE CHANGE (REVERSING BOX ASSEMBLY 2)

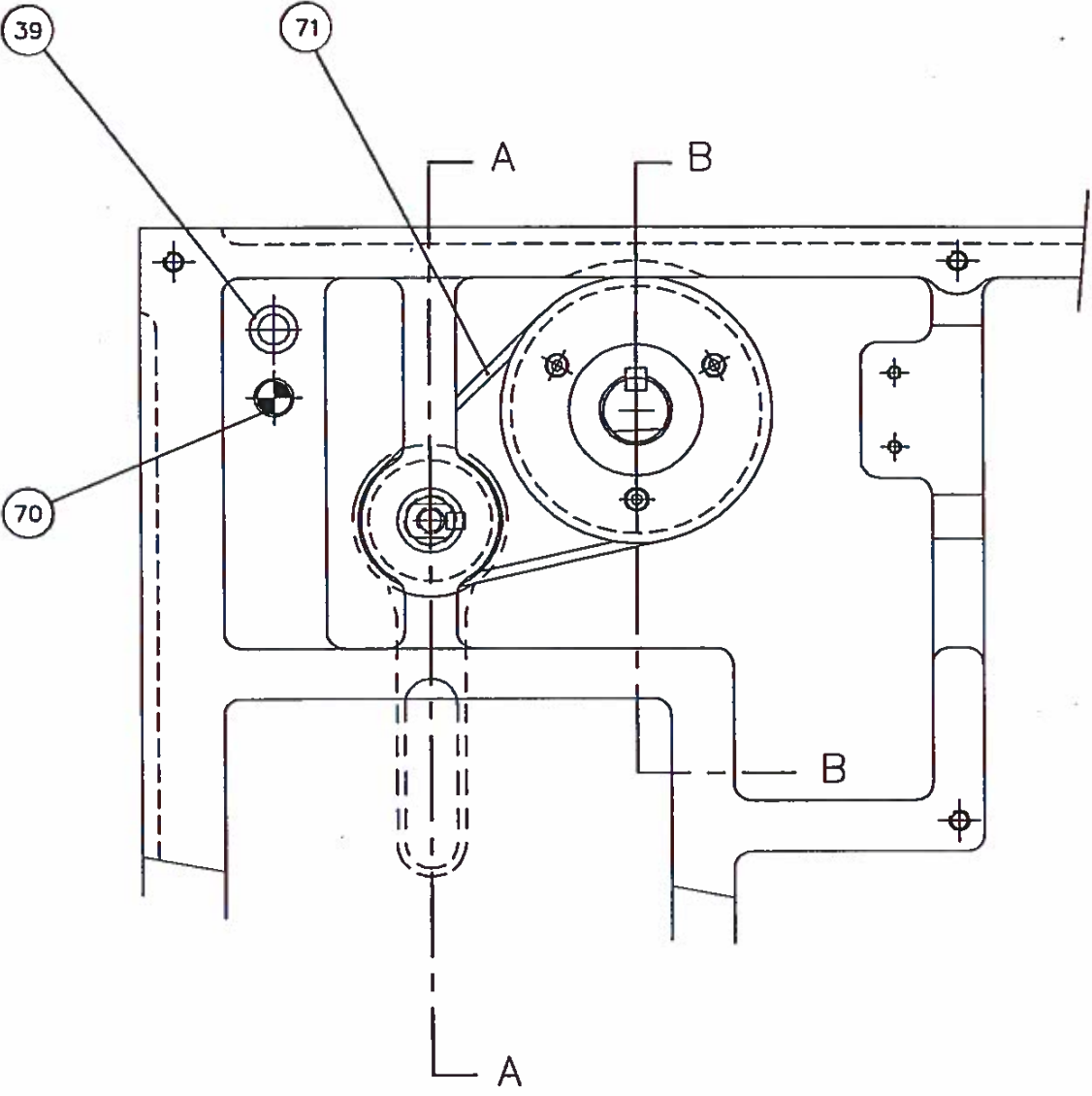

Item No.	Description	Part No.

MASTIFF TOPSLIDE ASSEMBLY

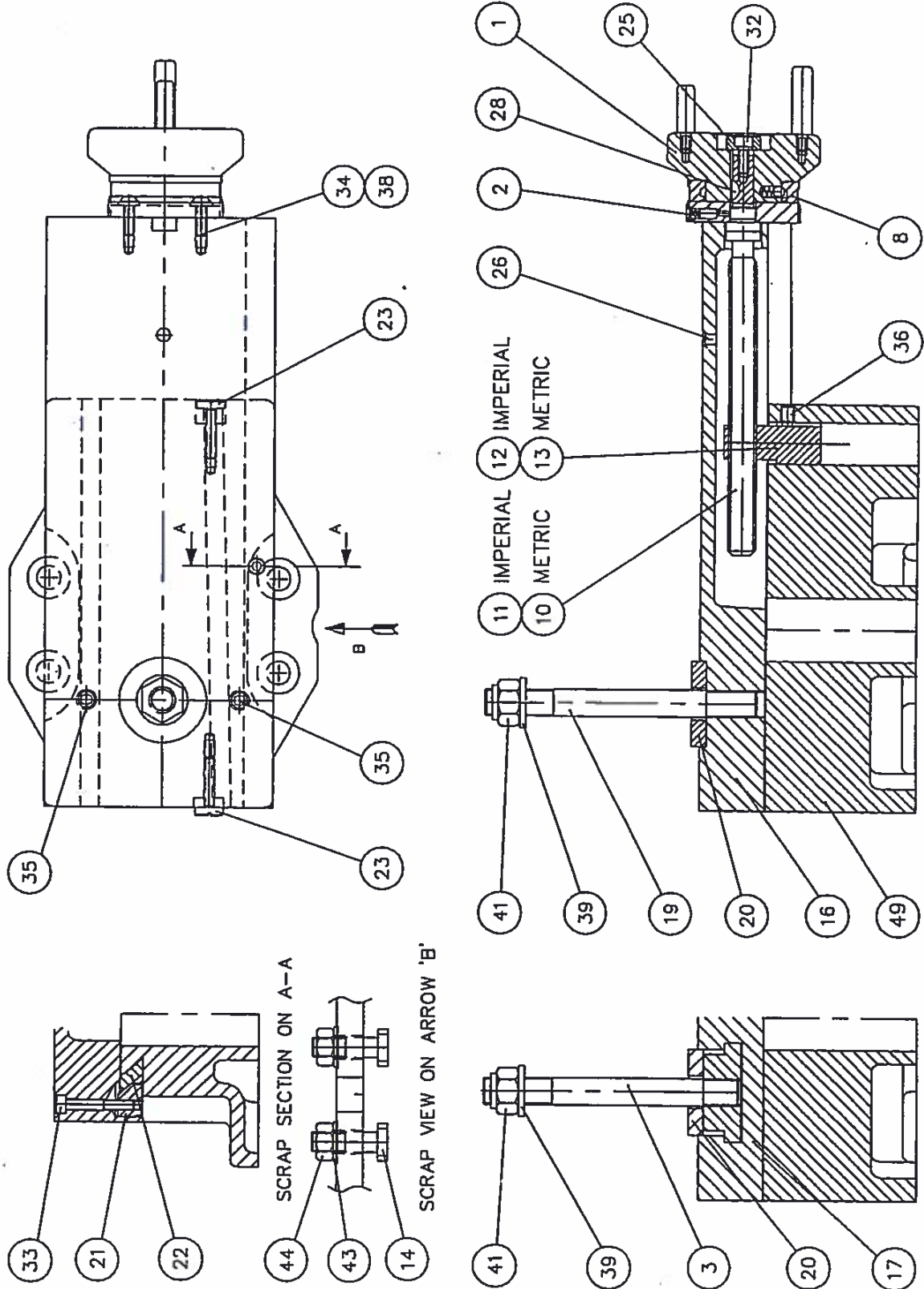

TOPSLIDE ASSEMBLY

A125 - 0604

Item No.	Description	Part No.
1	TOPSLIDE HANDWHEELSUB-ASSEMBLY	A842 - 0027
2	TOPSLIDE KEEP SUB-ASSEMBLY	A806 - 0584
3	CLAMP BOLT SUB-ASSEMBLY	A812 - 0013
8	METRIC INDEX RING	D424 - 0158
9	IMPERIAL INDEX RING	D424 - 0143
10	METRIC TOPSLIDE SCREW	D697 - 0372
11	IMPERIAL TOPSLIDE SCREW	D697 - 0373
12	METRIC TOPSLIDE NUT	D536 - 0313
13	IMPERIAL TOPSLIDE NUT	D536 - 0314
14	SWIVEL SLIDE BOLT	D048 - 0163
16	SOLID TOPSLIDE	D705 - 0125
17	SLOTTED TOPSLIDE	D705 - 0126
19	TOOLHOLDER STUD	D711 - 0200
20	COLLAR	D133 - 0124
21	LOCK PAD	D557 - 0144
22	GIB STRIP	D345 - 0080
23	GIB ADJUSTING SCREW	D697 - 0345
24	COMPRESSION SPRING	D707 - 0021
25	PIN	D560 - 0296
26	CONCAVE LUBRICATOR 6mm	B454 - 2004
27	BALL BEARING 1/4"	B326 - 8107
28	WOODRUFF KEY 13x5x3	B343 - 2002
32	HEXAGON SOCKET WEGLOK CAP HEAD SCREW M6x16	B164 - 0037
33	HEXAGON SOCKET CAP HEAD SCREW M6x40	B163 - 0042
34	HEXAGON SOCKET BUTTON HEAD SCREW M6x20	B163 - 1816
35	HEXAGON SOCKET CUP SET SCREW M12	B163 - 1594
36	HEXAGON SOCKET DOG POINT SET SCREW M8x12	B163Y1752
38	WASHER M6	B117 - 0009
39	WASHER M16	B117 - 0013
41	NYLOC NUT M16	B147 - 9008
43	WASHER M12	B117 - 0012
44	NUT M12	B147 - 9155
49	SWIVEL SLIDE	D705 - 0140

TOPSLIDE SUB-ASSEMBLIES

A125 - 0604

Item No.	Description	Part No.
1 2 3	HANDWHEELSUB-ASSEMBLY A842 - 0027 HANDWHEEL LONG HANDLE SHORT HANDLE	D383 - 0113 D382 - 0140 D382 - 0141
1 2 3	KEEP SUB-ASSEMBLY A806 - 0584 KEEP RING CONCAVE LUBRICATOR 6mm	D442 - 0087 D646 - 0013 B454 - 2004
1 2	CLAMP BOLT SUB-ASSEMBLY A812 - 0013 TOOLHOLDER STUD FLANGE STUD	D296 - 0019 D711 - 0201

SPARE PARTS

TAILSTOCK ASSEMBLY

A149-0708C & D

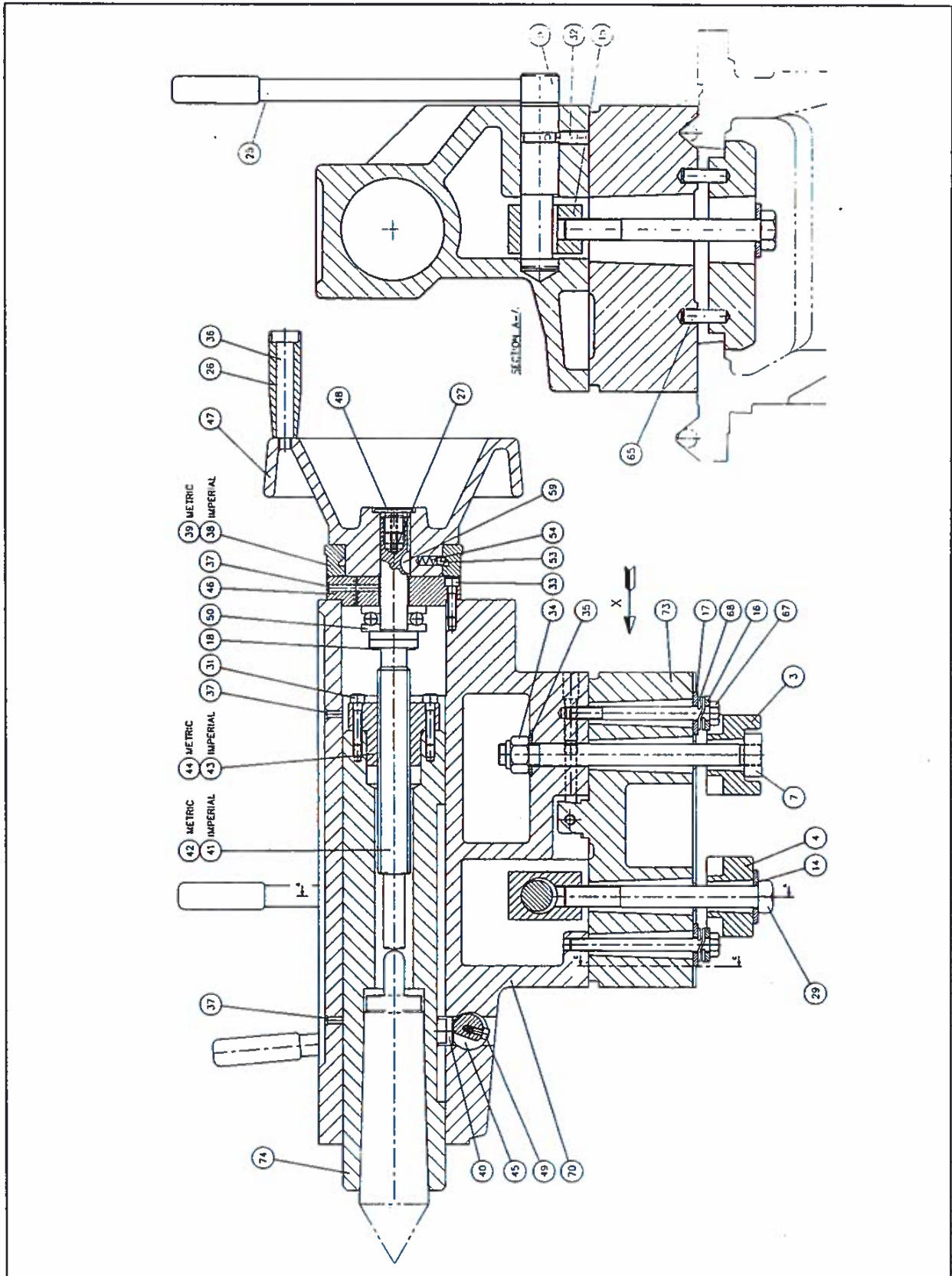

SPARE PARTS

A149-0708C & D

TAILSTOCK ASSEMBLY

Item No.	Part Number	Description	Qty
3	D131-0043	CLAMP PLATE REAR TAILSTOCK	1
4	D131-0044	CLAMP PLATE FRONT TAILSTOCK	1
5*	A840-0050A	CLAMP LEVER TAILSTOCK SUB-ASSEMBLY	1
7*	A840-0051B	CLAMP STUD SUB-ASSEMBLY	1
10	D699-0782	SHAFT DHOBI MARK	1
14	D931-0359	WASHER- TAILSTOCK CLAMP PLATE	1
15	D047-0131	BLOCK CLAMP TAILSTOCK	1
16	D931-0358	WASHER-TAILSTOCK CLAMPING	2
17	D931-0360	WASHER-TAILSTOCK CLAMPING	2
18	D931-0315	NYLON 66 OR EQUIV WASHER	1
19	D725-0027	VEE SHIELD	1
20	D707-0068	SPRING 6,7,8&10 IN M/CS	1
21	D937-0018	BED VEE WIPER	1
22	D725-0013	WIPER FLAT SHIELD	1
23	D707-0051	LEAF SPRING	1
24	D937-0010	BED FLAT WIPER	1
25	D382-0107	HANDLE	2
26	D382-0127	HANDLE TAILSTOCK	1
27	B163-1657	SET SCREW CONE PT.M 6X 40 HEXAGON	1
28	FS-0290	M5 X 16 BUTTON HEAD CAP SCREW	4
29	D048-0165	BOLT-ESLOK TAILSTOCK	1
30	FS-0354	M6X16 HALF DOG POINT SCREW	2
31	FS-0170	M8 X 40 SOCKET HEAD CAP SCREW	4
32	FS-0380	M12 X 20 DOG POINT SCREW	2
33	FS-0166	M8 X 30 SOCKET HEAD CAP SCREW	4
34	FS-0979	M20 NYLOC NUT	1
35	FP-0100	M20 BRIGHT WASHER	1
36	B163-1884	SHOULDER SCREW 16 DIA X 90 LG	1
37	OC-0010	6MM DRIVE IN CONCAVE OIL NIPPLES 6 DIA	3
38	D424-0163	INDEX RING - IMPERIAL	1
39	D424-0162	INDEX RING - METRIC	1
40	D441-0081	BARREL KEY TAILSTOCK	1
41	D697-0446	TAILSTOCK SCREW IMPERIAL	1
42	D697-0445	TAILSTOCK SCREW METRIC	1
43	D536-0332	NUT TAILSTOCK BRL IMPERIAL	1
44	D536-0331	NUT TAILSTOCK BRL METRIC	1
45*	A840-0049A	BARREL CLAMP SUB-ASSEMBLY	1
46*	A806-0571A	KEEP SUB ASY TAILSTOCK SUB-ASSEMBLY	1
47	D383-0083	HANDWHEEL TAILSTOCK	1
48	D566-0120	PLUG TAILSTOCK HANDWHEEL	1
49	FS-0130	M6 X 10 SOCKET HEAD CAP SCREW	1
50	B325-0250	THRUST BEARING FAG 51405 25X6	1
53	UB-0008	8MM STEEL BALL	3

SPARE PARTS

TAILSTOCK ASSEMBLY

A149-0708C & D

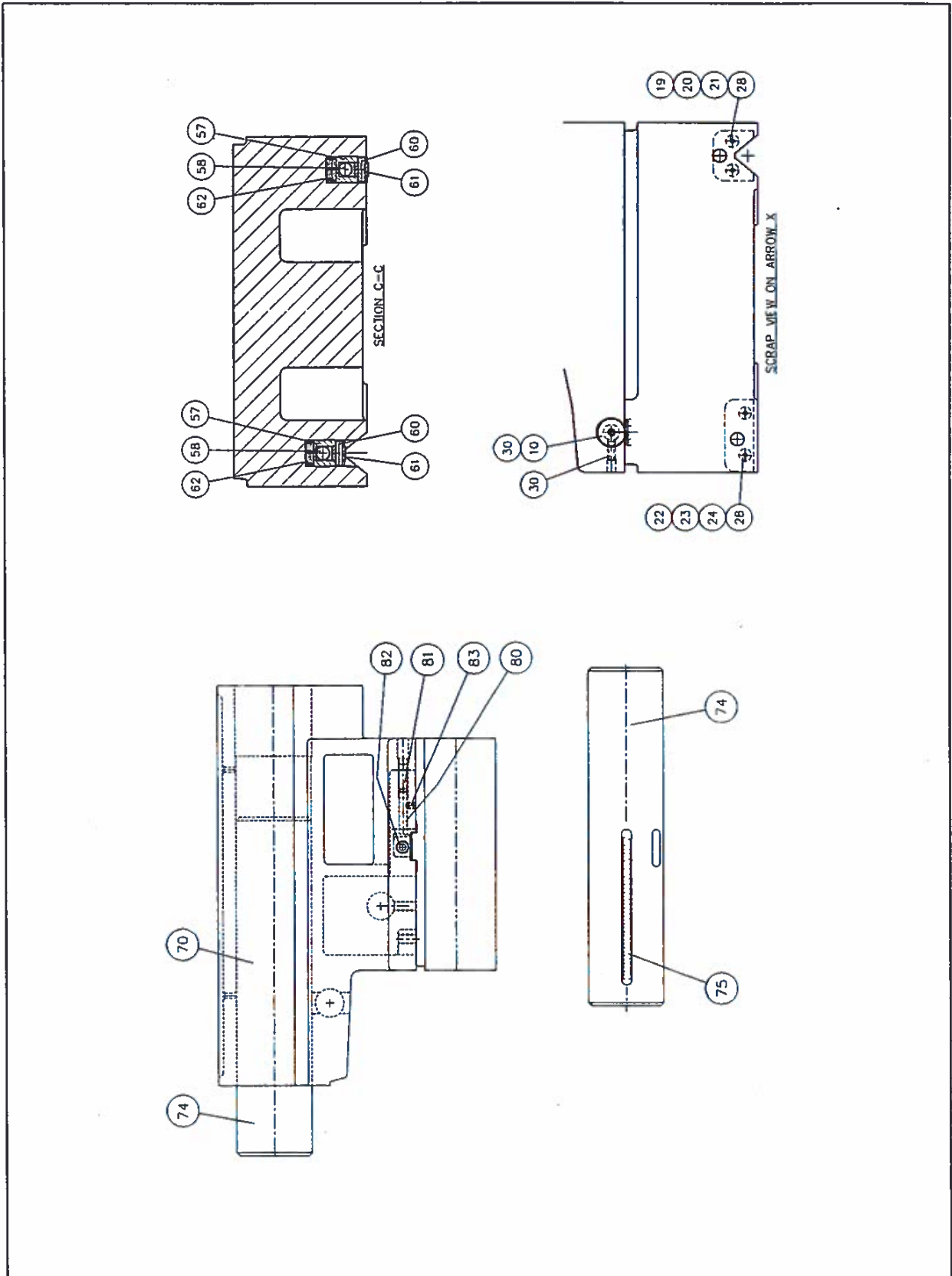

SPARE PARTS

A149-0708C & D

TAILSTOCK ASSEMBLY

Item No.	Part Number	Description	Qty
54	B365-1154	SPRING FLEXO REF 113207	3
57	D388-0143	ROLLER HOUSING STD.	4
58	D560-0248	PIN DOWEL T/STOCK	4
59	KA-0190	6.0 X 9.0 X 22MM WOODRUFF KEYS	1
60	D560-0178	PIN ROLLER	4
61	B337-2001	INA NEEDLE BRGS NK 5/10	4
62	B365-6040	ANDERTON DISC SPRING	24
65	B111-5167	SPIROL PIN 12 DIA X 40 MBK	4
67	B166Y0207	M12 X 130 LG HEXAGON HEAD BOLT	2
68	B116-2212	WASHER DOUBLE COIL 3/4"	2
70	D827-0133	BODY	1
73	D827-0070	BASE	1
74	D044-0054	BARREL	1
75	D537-0896	STAINLESS STEEL GRADUATION PLATE	1
80	D560-0302	PIN	1
81	FS-0382	M12 X 35 DOG POINT SCREW	1
82	FS-0195	M10 X 70 SOCKET HEAD CAP SCREW	2
83	FS-0790	M8 X 10 DOG POINT NYLON SCREW	1

SPARE PARTS

TAILSTOCK SUB ASSEMBLIES

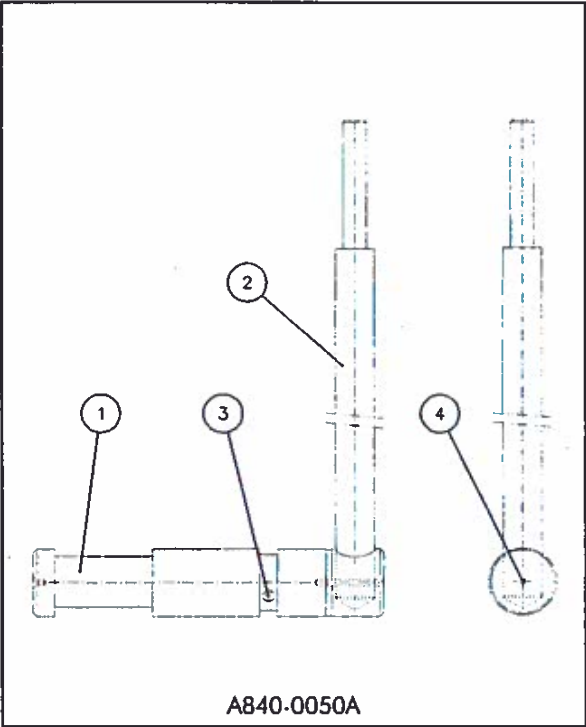
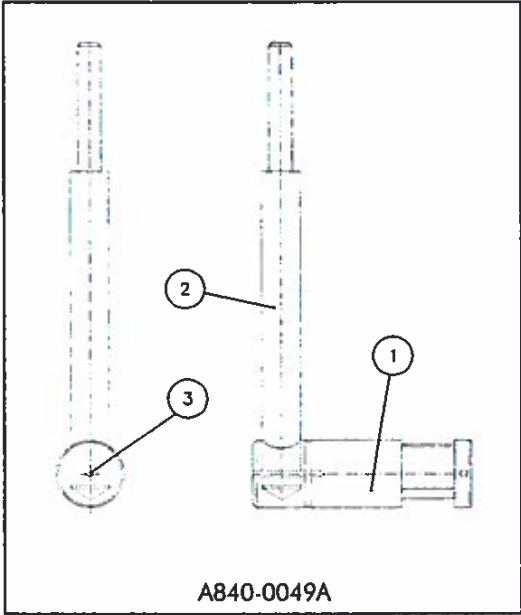
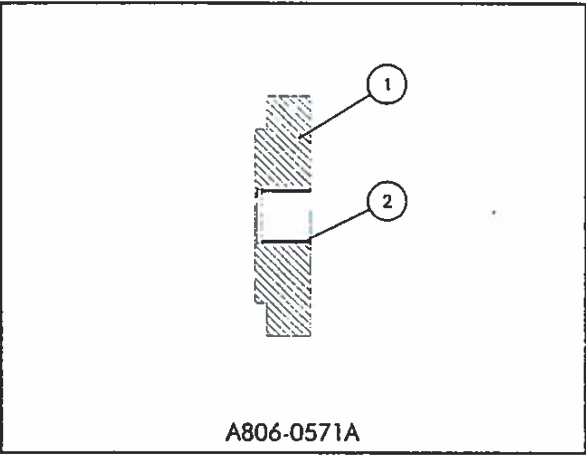
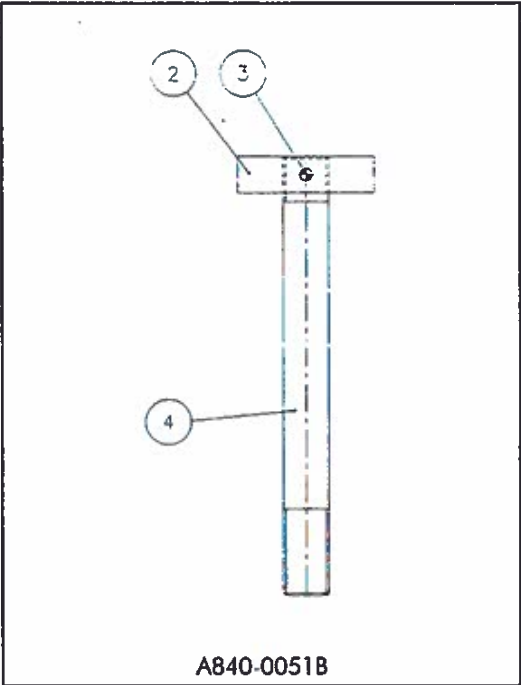

SPARE PARTS

TAILSTOCK SUB ASSEMBLIES

Item No.	Part Number	Description	Qty
1	A806-0571A	KEEP SUB ASSEMBLY	1
	D442-0085	KEEP	
2	B311-1665	GLACIER BUSH	1
	A840-0050A	CLAMPING LEVER SUB ASSEMBLY	
1	D123-0118	ECCENTRIC STUD	1
2	D717-0118	CLAMP LEVER	1
3	B111Y6039	DOWEL PIN 6 DIA X 16	1
4	B111-5065	SPIROL PIN 3 DIA X 30	1
	A840-0051B	CLAMP STUD SUB ASSEMBLY	
2	D565-1056	STUD PLATE	1
3	B111-5099	SPIROL PIN 5 DIA X 35	1
4	D711-0202	STUD	1
	A840-0047A	BARREL CLAMP SUB ASSEMBLY	
1	D123-0117	ECCENTRIC STUD	1
2	D717-0104	STEM	1
3	B111-5065	SPIROL PIN 3 DIA X 30	1

MASTIFF VS BELTS AND PULLEYS ASSEMBLY

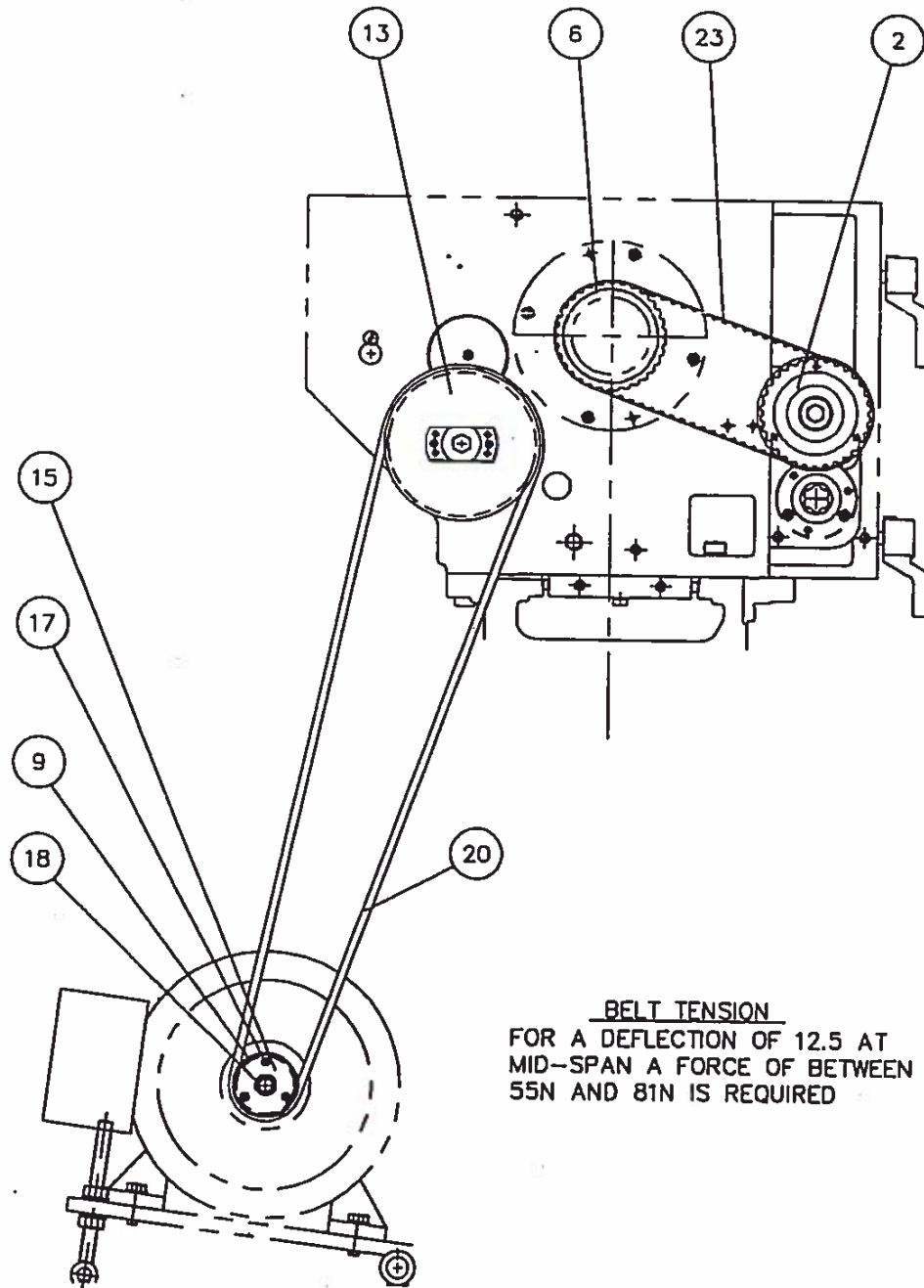

BELTS AND PULLEYS ASSEMBLY

A107 - 0601B

Item No.	Description	Part No.
2	32T PULLEY SUB-ASSEMBLY	A824 - 0036A
6	32T PULLEY	D570 - 0352
13	172mm DIA. INPUT PULLEY	D570 - 0350
14	MOTOR PULLEY	D570 - 0373
15	MOTOR RETAINING PLATE	D565 - 1072
17	HEXAGON SOCKET BUTTON HEAD SCREW M6x16	FS - 0296
18	HEXAGON SOCKET CAP HEAD SCREW M16x40	FS - 0222
20	POLY VEE BELT REF 770L12	B345 - 5441
23	TIMING BELT REF 360H100	B346 - 1221
	<p>32T PULLEY SUB-ASSEMBLY A824 - 0036A</p>	
1	32T REVERSE BOX PULLEY	D570 - 0364
2	BELT RETAINING PLATE	D565 - 1073
3	HEXAGON SOCKET COUNTERSUNK SCREW M4 x 12	FS - 0428

DCIN - 20607	MSC/MSH	Serial No.		Assembly - A107 - 0601B	Issue 5	02.01.96
--------------	---------	------------	--	-------------------------	---------	----------

NAMEPLATE ASSEMBLY

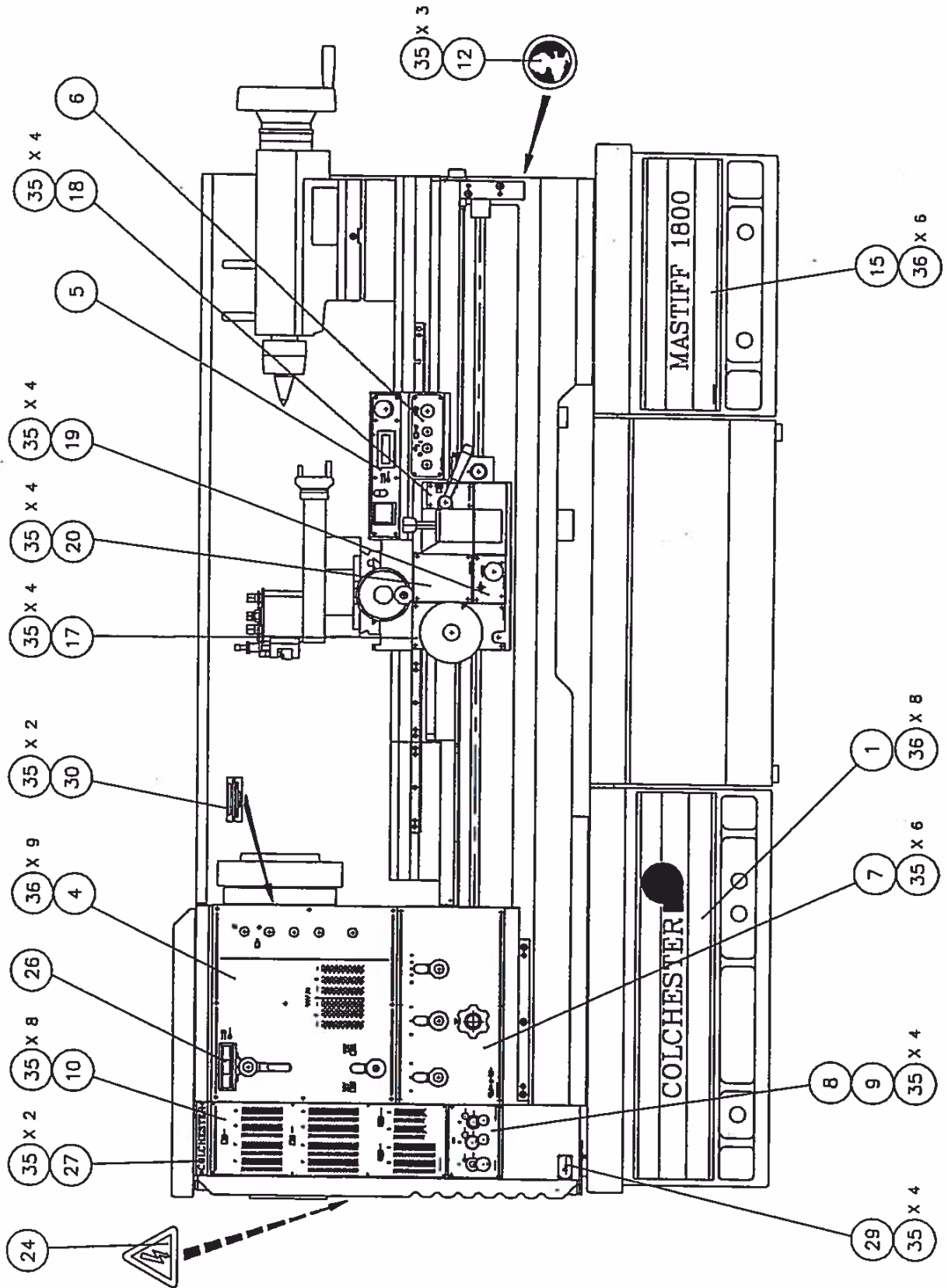

NAMEPLATE ASSEMBLY

A161 - 0606

Item No.	Description	Part No.
1	'COLCHESTER' PLATE	D537 - 1095
4	HEADSTOCK PUSH BUTTON AND REVERSE BOX PLATE	D537 - 1098
5	UPPER APRON CONTROL PLATE	D537 - 1099
6	LOWER APRON CONTROL PLATE	D537 - 1100
7	GEARBOX PLATE	D537 - 1101
8	METRIC CHANGE WHEEL PLATE	D537 - 1102
9	IMPERIAL CHANGE WHEEL PLATE	D537 - 1103
10	THREAD AND FEED PLATE	D537 - 1104
12	'WORLD TURNS ' PLATE	D537 - 0783
15	'MASTIFF 1800' PLATE	D537 - 1106
17	APRON PLATE	D537 - 1108
18	APRON HALF NUTPLATE	D537 - 1111
19	APRON KNOCK-OFF	D537 - 1112
20	APRON BLANK PLATE	D537 - 1113
24	ELECTRICAL WARNING FLASH	D565Y0406
26	SPEED RANGE PLATE	D537 - 1110
27	SMALL 'COLCHESTER' PLATE	D537 - 1057
28	RED ARROW LABEL	D537 - 1039
29	'600 GROUP' LOGO PLATE	D537 - 1071
30	CHUCK WARNING PLATE	D537 - 1082
35	TAPTITE SCREW M3x5	B123 - 6065
36	HEXAGON SOCKET BUTTON HEAD SCREW M6x10	B163 - 1813

SHEET METAL PACK (1)

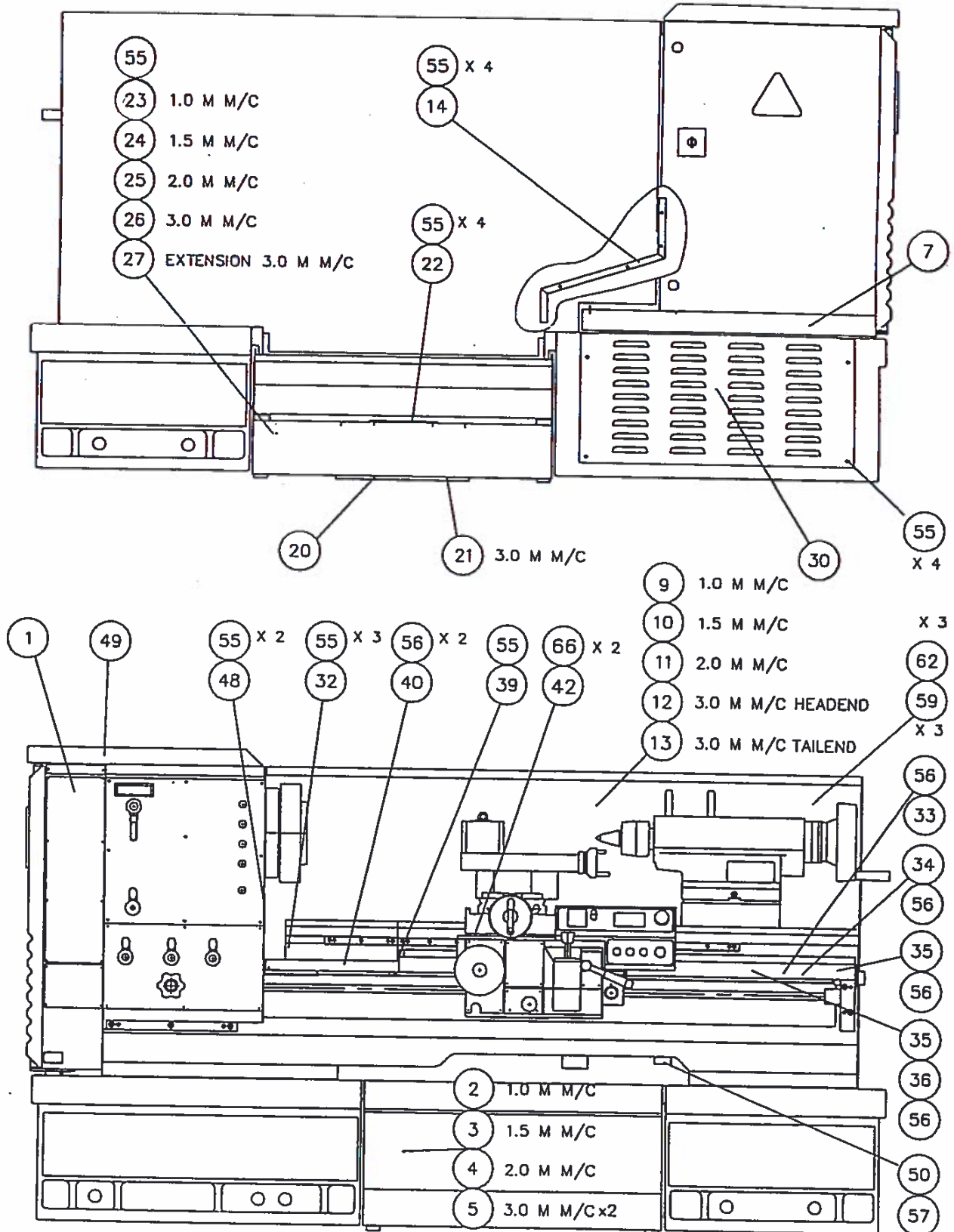

Item No.	Description	Part No.
1	HEAD END COVER	D132 - 0812
2	SWARF BIN 1.0 METRE MACHINE	D382 - 0164
3	SWARF BIN 1.5 METRE MACHINE	D382 - 0165
4	SWARF BIN 2.0 METRE MACHINE	D382 - 0166
5	SWARF BIN 3.0 METRE MACHINE	D382 - 0167
6	SPLASHGUARD SUPPORT BRACKET	D050 - 0748
7	CABLE SUPPORT PLATE	D565 - 1071
9	SPLASHGUARD 1.0 METRE MACHINE	D346 - 0399
10	SPLASHGUARD 1.5 METRE MACHINE	D346 - 0400
11	SPLASHGUARD 2.0 METRE MACHINE	D346 - 0401
12	SPLASHGUARD (HEADEND) 3.0 METRE MACHINE	D346 - 0404
13	SPLASHGUARD (TAILEND) 3.0 METRE MACHINE	D346 - 0405
14	SPLASHGUARD BRACKET	D050 - 0750
15	SPLASHGUARD SUPPORT	D718 - 0082
16	SPLASHGUARD BRACKET	D050 - 0333
20	STANDARD COOLANT TANK	D828 - 0061
21	3.0 METRE COOLANT TANK	D828 - 0072
22	PUMP MOUNTING PLATE	D565 - 0943
23	COOLANT TANK COVER 1.0 METRE MACHINE	D132 - 0816
24	COOLANT TANK COVER 1.5 METRE MACHINE	D132 - 0817
25	COOLANT TANK COVER 2.0 METRE MACHINE	D132 - 0818
26	COOLANT TANK COVER 3.0 METRE MACHINE	D132 - 0819
27	COOLANT TANK COVER 3.0 METRE EXTENSION	D132 - 0820
28	H/E PLINTH MOTOR COVER	D132 - 0821
29	H/E PLINTH HYDRAULICS COVER	D132 - 0822
30	H/E PLINTH REAR COVER	D132 - 0823
31	T/E PLINTH COVER	D132 - 0824
32	G/BOX EXTENSION COVER	D132 - 0825
33	LEADSCREW COVER 1.0 METRE MACHINE	D132 - 0826
34	LEADSCREW COVER 1.5 METRE MACHINE	D132 - 0827
35	LEADSCREW COVER 2.0 AND 3.0 METRE MACHINES	D132 - 0828
36	LEADSCREW COVER 3.0 METRE MACHINE	D132 - 0829
39	LEADSCREW COVER BRACKET	D050 - 0749
40	GAP AREA COVER	D132 - 0831
41	CHUCK GUARD MOUNTING PLATE	D565 - 1089
42	APRON DRAIN CHUTE	D147 - 0034
48	INFILL PLATE	D565 - 1062
49	HEADSTOCK TRUNKING	D132 - 0835
50	TRUNKING SUPPORT BRACKET	D050 - 0754
55	HEXAGON SOCKET BUTTON HEAD SCREW M6x10	B163 - 1813
56	HEXAGON SOCKET PLATED BUTTON HEAD SCREW M6x12	B163 - 1900
57	HEXAGON SOCKET CAP HEAD SCREW M6x16	B163 - 0037
59	HEXAGON SOCKET PLATED BUTTON HEAD SCREW M8x20	B163 - 1905
61	WASHER M6	B117 - 0048
62	WASHER M8	B117 - 0034
63	M6 NUT	B147 - 9152
64	HEXAGON SOCKET SET SCREW M10x25	B163 - 1588
65	HEXAGON HEAD SET SCREW M12	B166 - 0218
66	HEXAGON SOCKET BUTTON HEAD SCREW M4x10	B163 - 1804

SHEET METAL PACK (2)

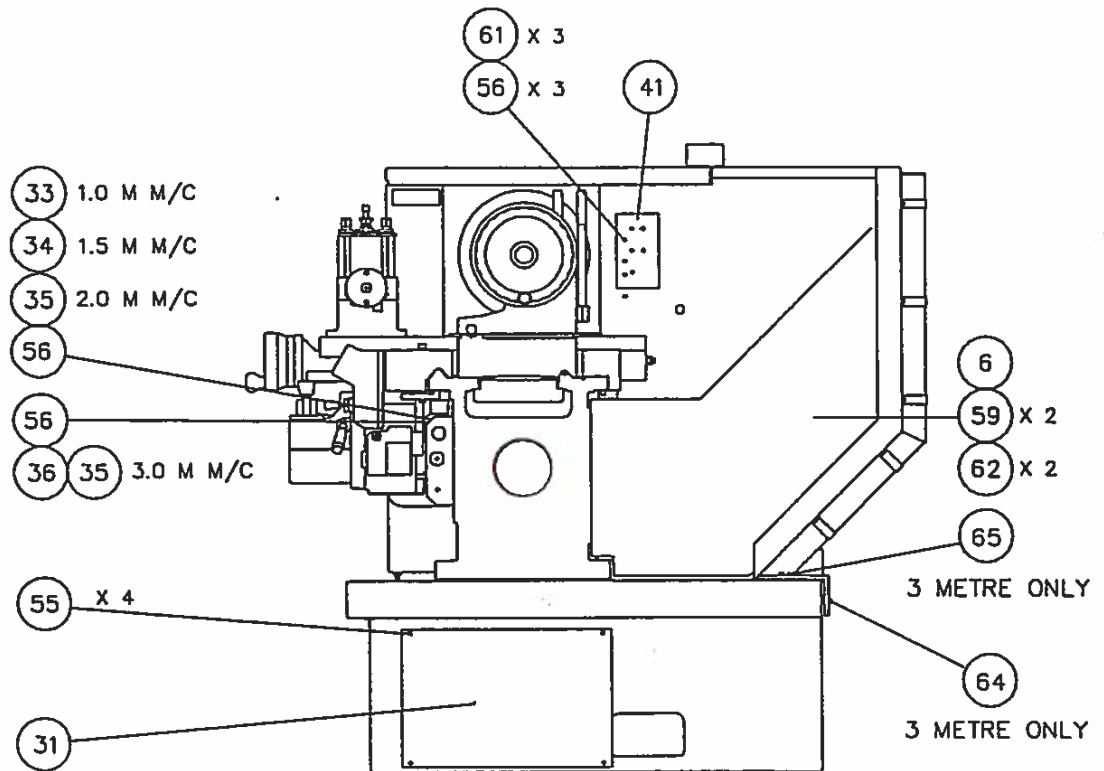
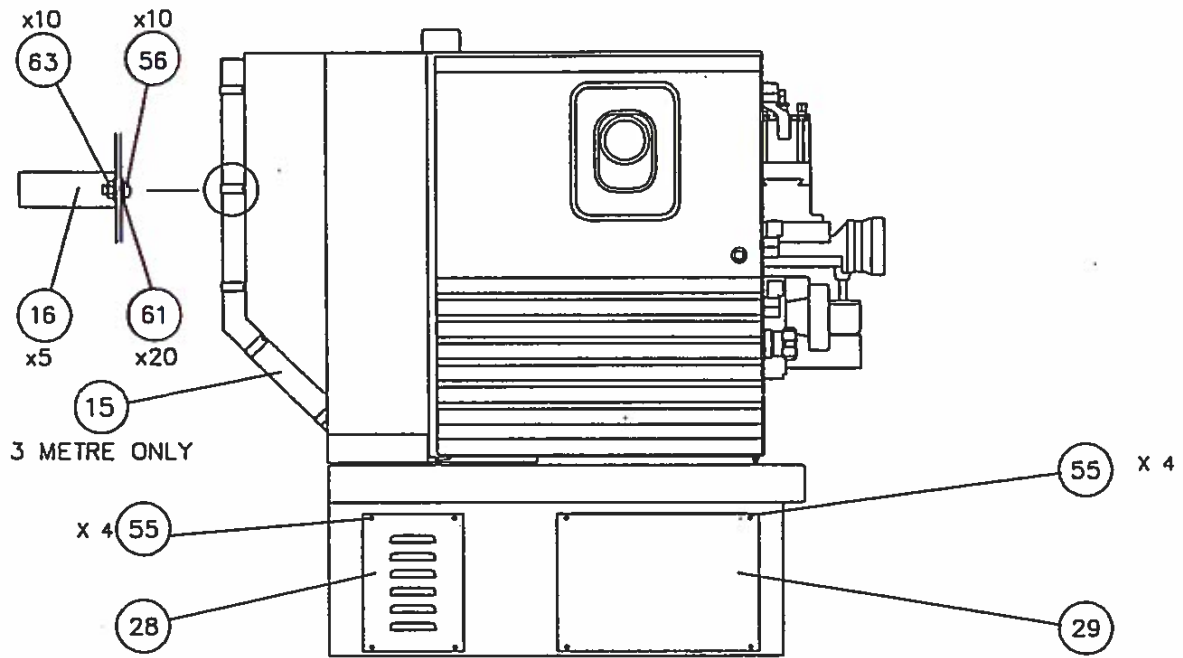

STANDARD TOOL KIT

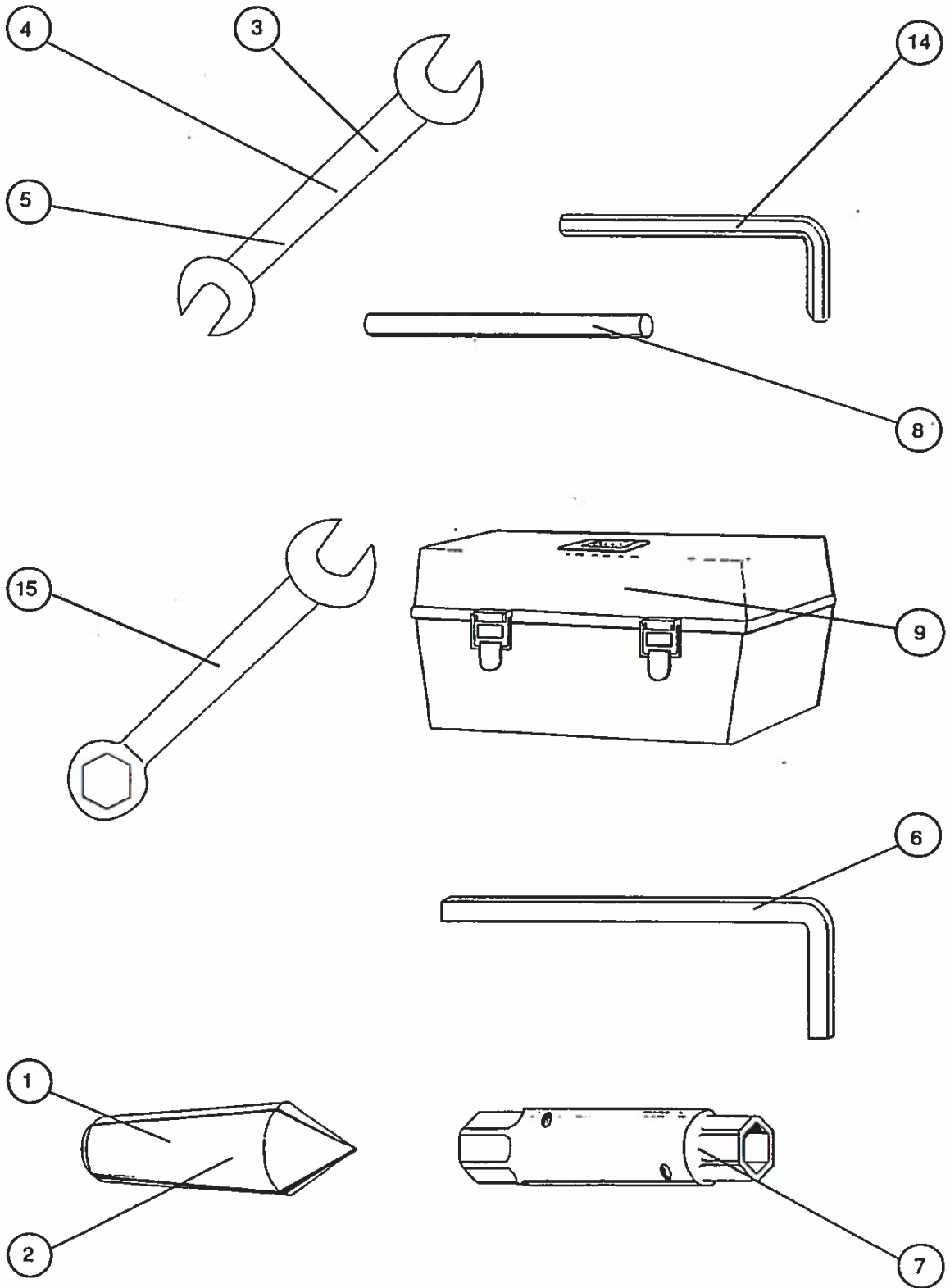

TOOLBOX ASSEMBLY

A180 - 0703

Item No.	Description	Part No.
1	HARD CENTRE No. 5 MORSE TAPER	B916 - 2085
2	HARD CENTRE No. 6 MORSE TAPER	B916 - 2086
3	O/E SPANNER 17 x 19 mm A/F	B982 - 0030
4	O/E SPANNER 22 x 24 mm A/F	B982 - 0034
5	O/E SPANNER 27 x 30 mm A/F	B982 - 0037
6	L' CAMLOCK KEY	D441 - 0053
7	BOX SPANNER 24 x 27 AF	B981 - 1559
8	TOMMY BAR 3/8"x6"	B981 - 1804
9	PLASTIC TOOLBOX	R647 - 0120
14	SET HEXAGON (ALLEN) KEYS 2mm-10mm	A894 - 0004
15	13mm COMBINATION SPANNER	B981 - 2850
	SET HEXAGON (ALLEN) KEYS 2mm-10mm	A894 - 0004
8	ALLEN KEY 3/8" A/F	B981 - 1112
12	ALLEN KEY 2.0mm A/F	B982 - 0002
13	ALLEN KEY 2.5mm A/F	B982 - 0003
14	ALLEN KEY 3.0mm A/F	B982 - 0004
15	ALLEN KEY 4.0mm A/F	B982 - 0005
16	ALLEN KEY 5.0mm A/F	B982 - 0006
17	ALLEN KEY 6.0mm A/F	B982 - 0007
18	ALLEN KEY 8.0mm A/F	B982 - 0008
19	ALLEN KEY 10.0mm A/F	B982 - 0009

MASTIFF ACCESSORIES

INDEX

ITEM

2. Quick Change Toolpost
4 Way Toolpost
 3. Perspex Chipguard
 4. Stationary Steady
Large Capacity Stationary Steady
 5. Travelling Steady
 6. Rear Toolpost and Base
-

FOUR WAY TURRET TOOLPOST

A182 - 0606

Item No.	Description	Part No.
1	TYPE T4 FOUR WAY TURRET TOOLPOST COMPLETE	B935 - 1139
2	TEE NUTS FOR SLOTTED TOPSLIDE	B935 - 1438
3	HEXAGON SOCKET CAP HEAD SCREW 3/8"UNCx1 1/2" LONG	B143 - 7069

PERSPEX CHIP GUARD

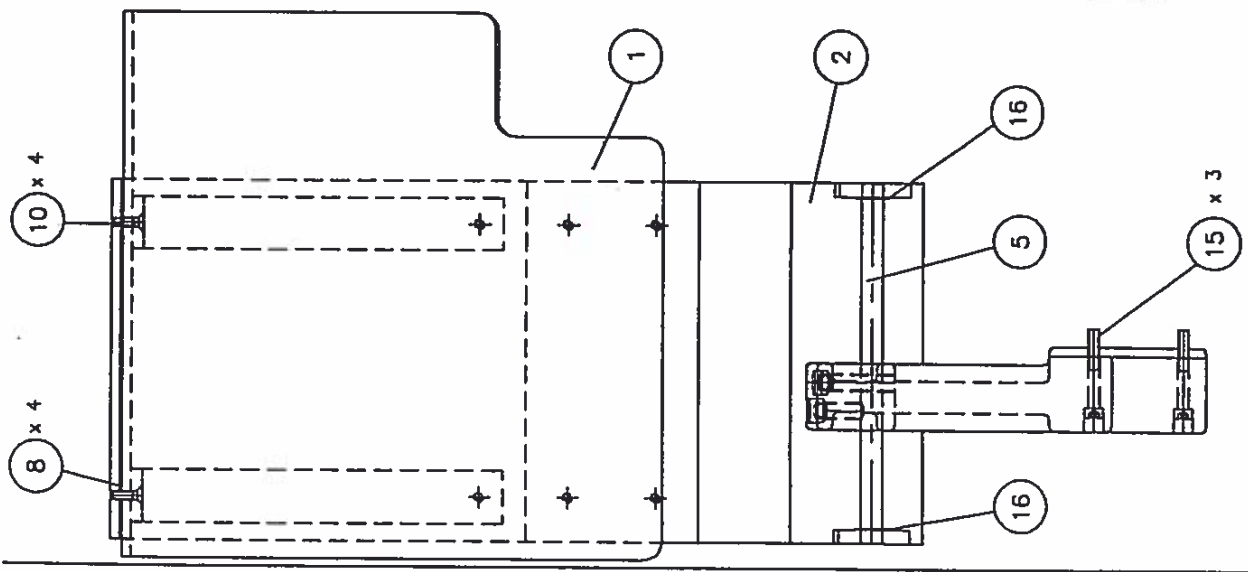
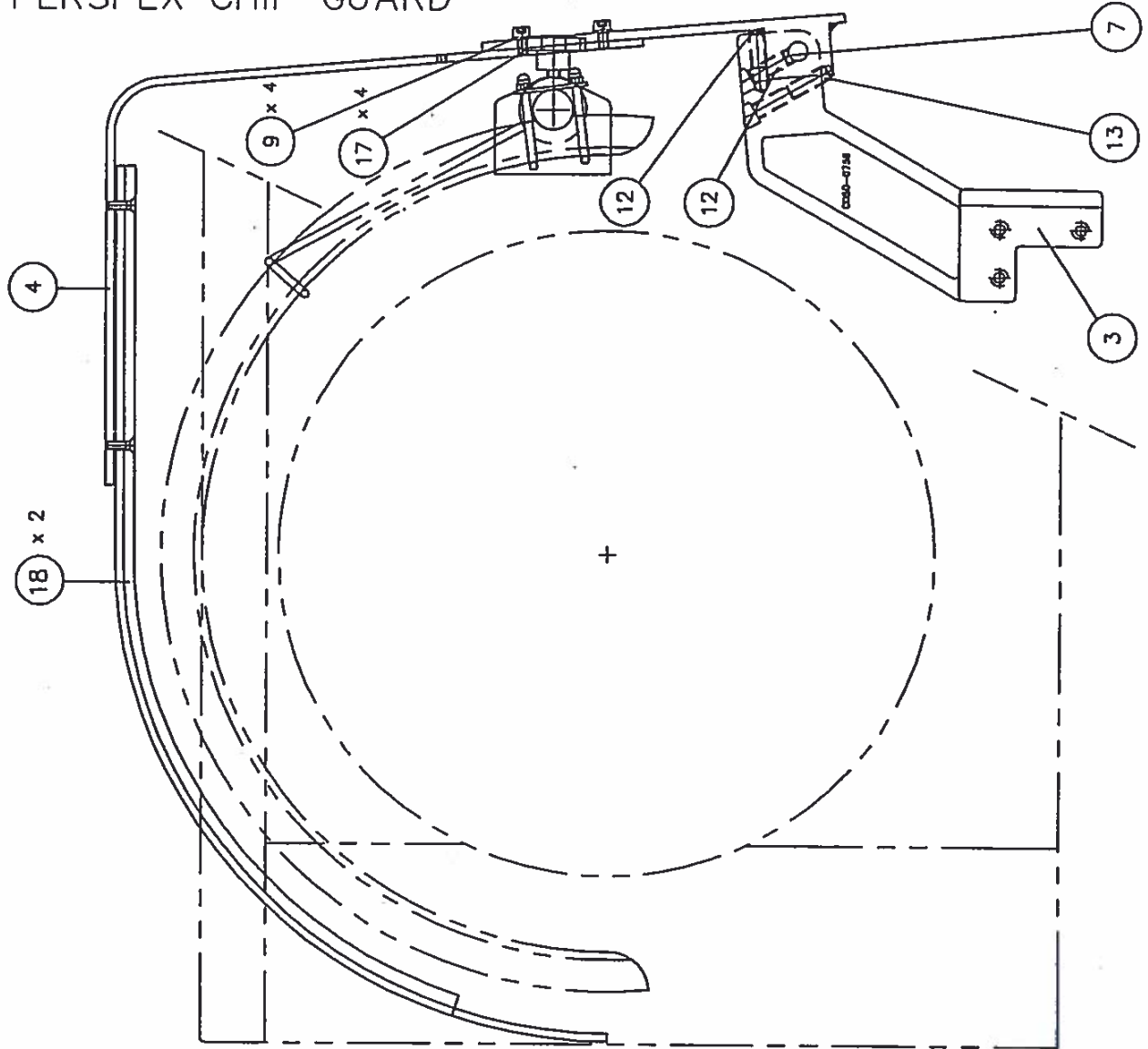

PERSPEX CHIP GUARD ASSEMBLY

A137 - 0622

Item No.	Description	Part No.
1	PERSPEX CHIP GUARD	D346 - 0403
2	LOWER SUPPORT	D718 - 0080
3	BRACKET	D050 - 0759
4	UPPER SUPPORT	D718 - 0081
5	SHAFT	D699 - 0820
7	PLUG	D566 - 0203
8	FIBRE WASHER 1/4" IDx1/2" OD	B411 - 0006
9	WASHER M6	B117 - 0009
10	HEXAGON SOCKET COUNTER SUNK SCREW M5x16	B163 - 1016
12	W/POINT SET SCREW M10x25	B163 - 1598
13	HEXAGON SOCKET DOG POINT SET SCREW M10x30	B163 - 1766
15	HEXAGON SOCKET CAP HEAD SCREW M6x45	B163 - 0043
16	CIRCLIP 1400-12	B363 - 0012
17	HEXAGON SOCKET CAP HEAD SCREW M6x12	B163 - 0036
18	SUPPORT BAR	D041 - 0251

STATIONARY STEADY

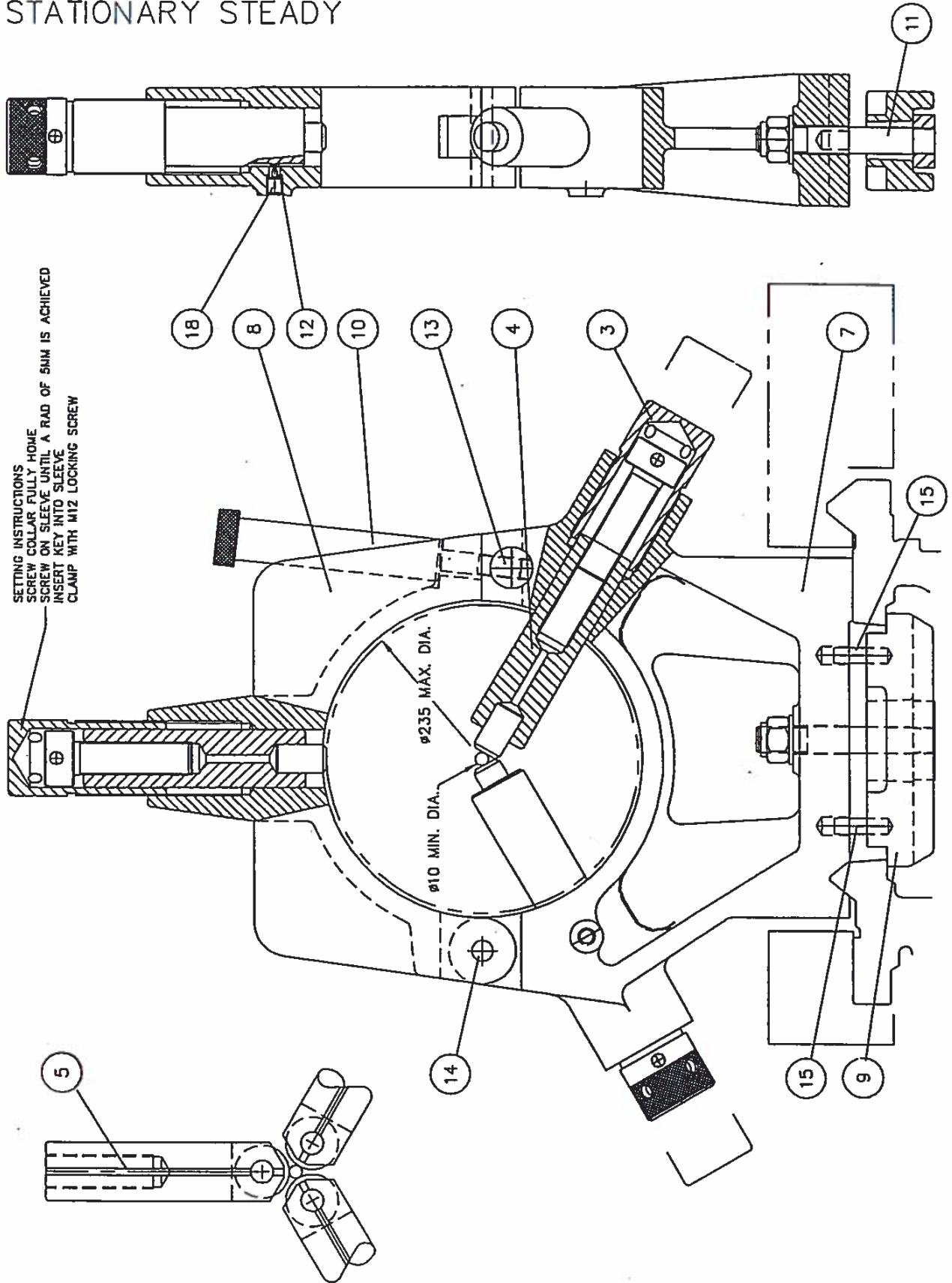

STATIONARY STEADY

A178 - 0714

Item No.	Description	Part No.
3	COLLAR SUB-ASSEMBLY	A820 - 0006
4	PAD TYPE FINGER SUB-ASSEMBLY	A882 - 0068A
5	ROLLER TYPE FINGER SUB-ASSEMBLY	A882 - 0068B
7	STEADY BASE	D722 - 0068
8	STEADY TOP	D722 - 0067
9	CLAMP PLATE	D131 - 0043
10	CLAMP SCREW	D697 - 0388
11	CLAMP STUD ASSEMBLY	A840 - 0053
12	KEY	D441 - 0082
13	PIN	D560 - 0321
14	HINGE PIN	D560 - 0322
15	SPIROL PIN 12x40	B111 - 5167
18	DOG POINT SCREW M12x12	B163 - 1780
19	WASHER M20	B117 - 0014
20	NYLOC NUT M20	B147 - 9010
	COLLAR SUB-ASSEMBLY	A820 - 0006
1	COLLAR	D133 - 0256
2	ADJUSTING SCREW	D697 - 0389
4	STEEL DOWEL 10x55	B111 - 6117
	PAD TYPE FINGER SUB-ASSEMBLY	A882 - 0068A
1	PAD FINGER	D300 - 0036
2	PAD	D421 - 0022
	ROLLER TYPE FINGER SUB-ASSEMBLY	A882 - 0068B
4	ROLLER FINGER	D300 - 0037
5	BEARING INA NATR 17PP	B337 - 1711
6	PIN	D560 - 0323
7	CONCAVE LUBRICATOR 6mm DIA.	B454 - 2004
8	HEXAGON SOCKET SET SCREW M4x8	B163 - 1511
	CLAMP STUD ASSEMBLY	A840 - 0053
1	STUD	D711 - 0206
2	STUD PLATE	D565 - 1056
3	SPIROL PIN 5x36	B111 - 5099

LARGE CAPACITY STATIONARY STEADY

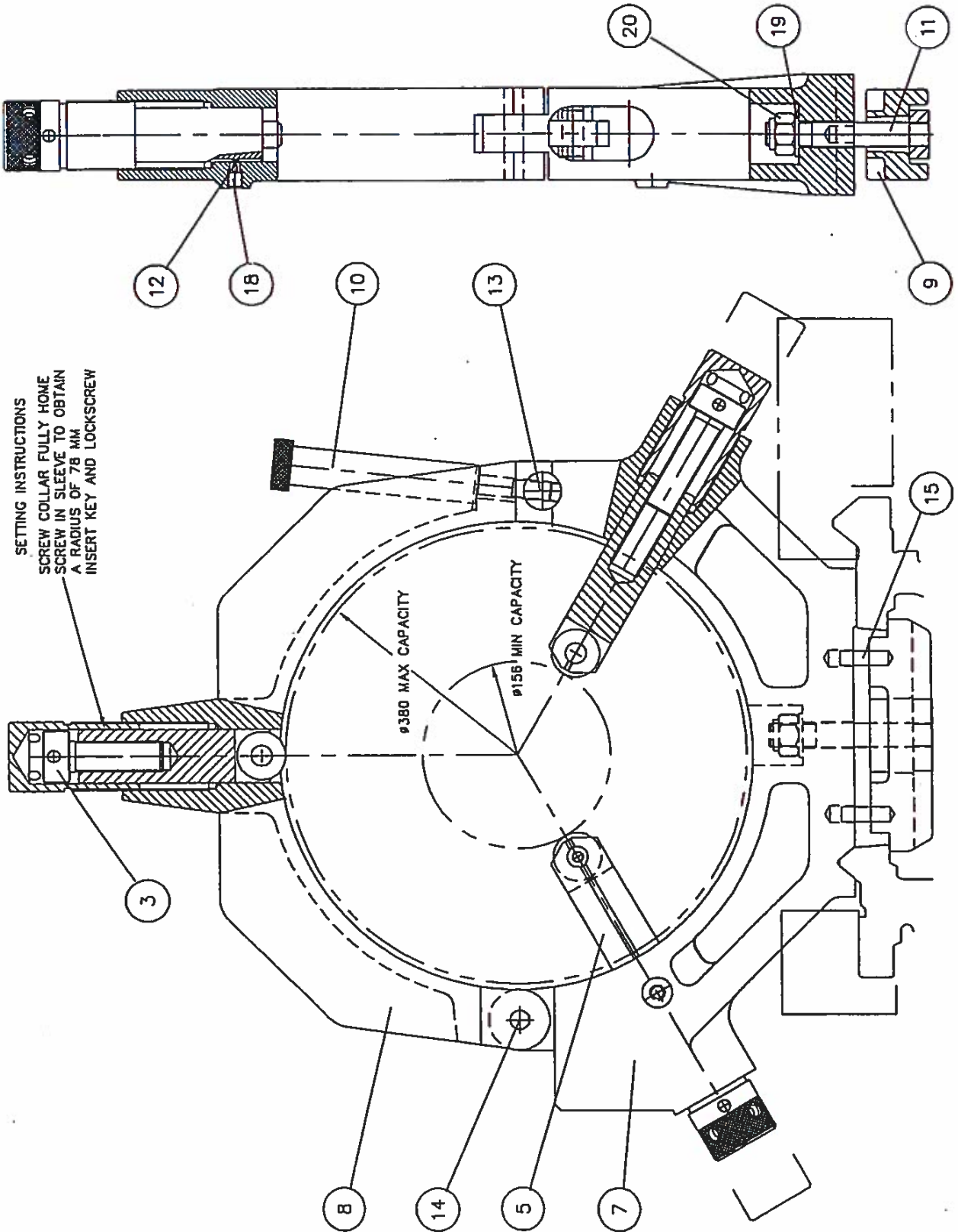

LARGE CAPACITY STATIONARY STEADY

A178 - 0715

Item No.	Description	Part No.
3	COLLAR SUB-ASSEMBLY	A820 - 0006
5	ROLLER TYPE FINGER SUB-ASSEMBLY	A882 - 0068B
7	STEADY BASE	D722 - 0070
8	STEADY TOP	D722 - 0069
9	CLAMP PLATE	D131 - 0043
10	CLAMP SCREW	D697 - 0388
11	CLAMP STUD ASSEMBLY	A840 - 0053
12	KEY	D441 - 0082
13	PIN	D560 - 0321
14	HINGE PIN	D560 - 0322
15	SPIROL PIN 12x40	B111 - 5167
18	DOG POINT SCREW M12x12	B163 - 1780
19	WASHER M20	B117 - 0014
20	NYLOC NUT M20	B147 - 9010
	COLLAR SUB-ASSEMBLY	A820 - 0006
1	COLLAR	D133 - 0256
2	ADJUSTING SCREW	D697 - 0389
4	STEEL DOWEL 10x55	B111 - 6117
	ROLLER TYPE FINGER SUB-ASSEMBLY	A882 - 0068B
4	ROLLER FINGER	D300 - 0037
5	BEARING INA NATR 17PP	B337 - 1711
6	PIN	D560 - 0323
7	CONCAVE LUBRICATOR 6mm DIA.	B454 - 2004
8	HEXAGON SOCKET SET SCREW M4x8	B163 - 1511
	CLAMP STUD ASSEMBLY	A840 - 0053
1	STUD	D711 - 0206
2	STUD PLATE	D565 - 1056
3	SPIROL PIN 5x36	B111 - 5099

TRAVELLING STEADY

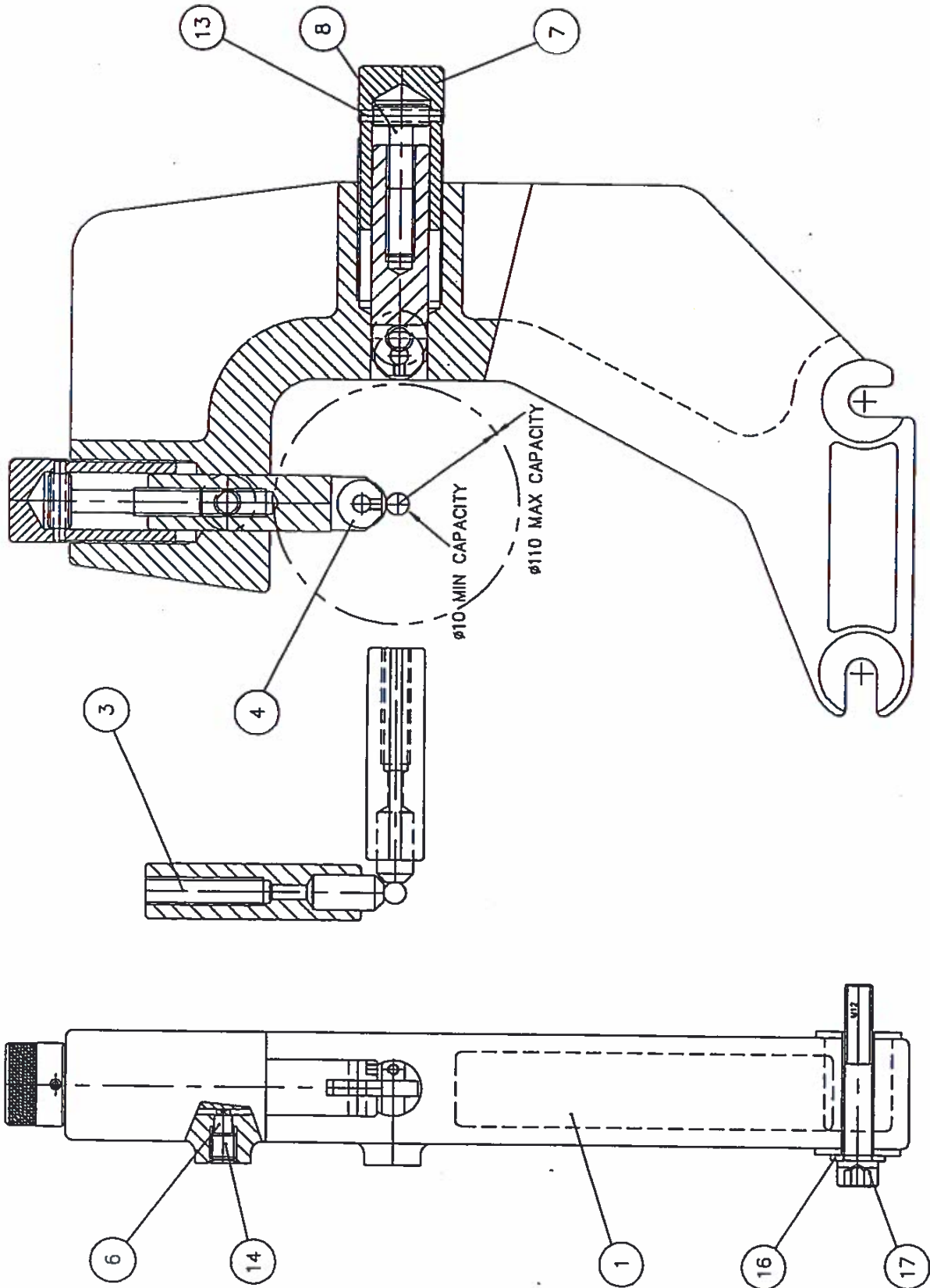

TRAVELLING STEADY

A178 - 0713

Item No.	Description	Part No.
1	TRAVELLING STEADY CASTING	D722 - 0072
3	PAD TYPE FINGER SUB -ASSEMBLY	A882 - 0069A
4	ROLLER TYPE FINGERSUB -ASSEMBLY	A882 - 0069B
6	KEY	D441 - 0082
7	COLLAR	D133 - 0257
8	SCREW	D697 - 0390
13	SPIROL PIN 5x36	B111 - 5099
14	DOG POINT SCREW M12x12	B163 - 1780
16	WASHER M12	B117 - 0012
17	HEXAGON SOCKET CAP HEAD SCREW M12x80	B163Y0094
	<p>PAD TYPE FINGER SUB-ASSEMBLY A882 - 0069A</p>	
1	PLAIN FINGER	D300 - 0038
2	PAD	D421 - 0023
	<p>ROLLER TYPE FINGER SUB-ASSEMBLY A882 - 0069B</p>	
5	ROLLER FINGER	D300 - 0039
6	PIN	D560 - 0324
9	BEARING FAG 6082Z	B315 - 0208
10	HEXAGON SOCKET CUP POINT SET SCREW M5x5	B163 - 1547

REAR TOOLPOST ASSEMBLY

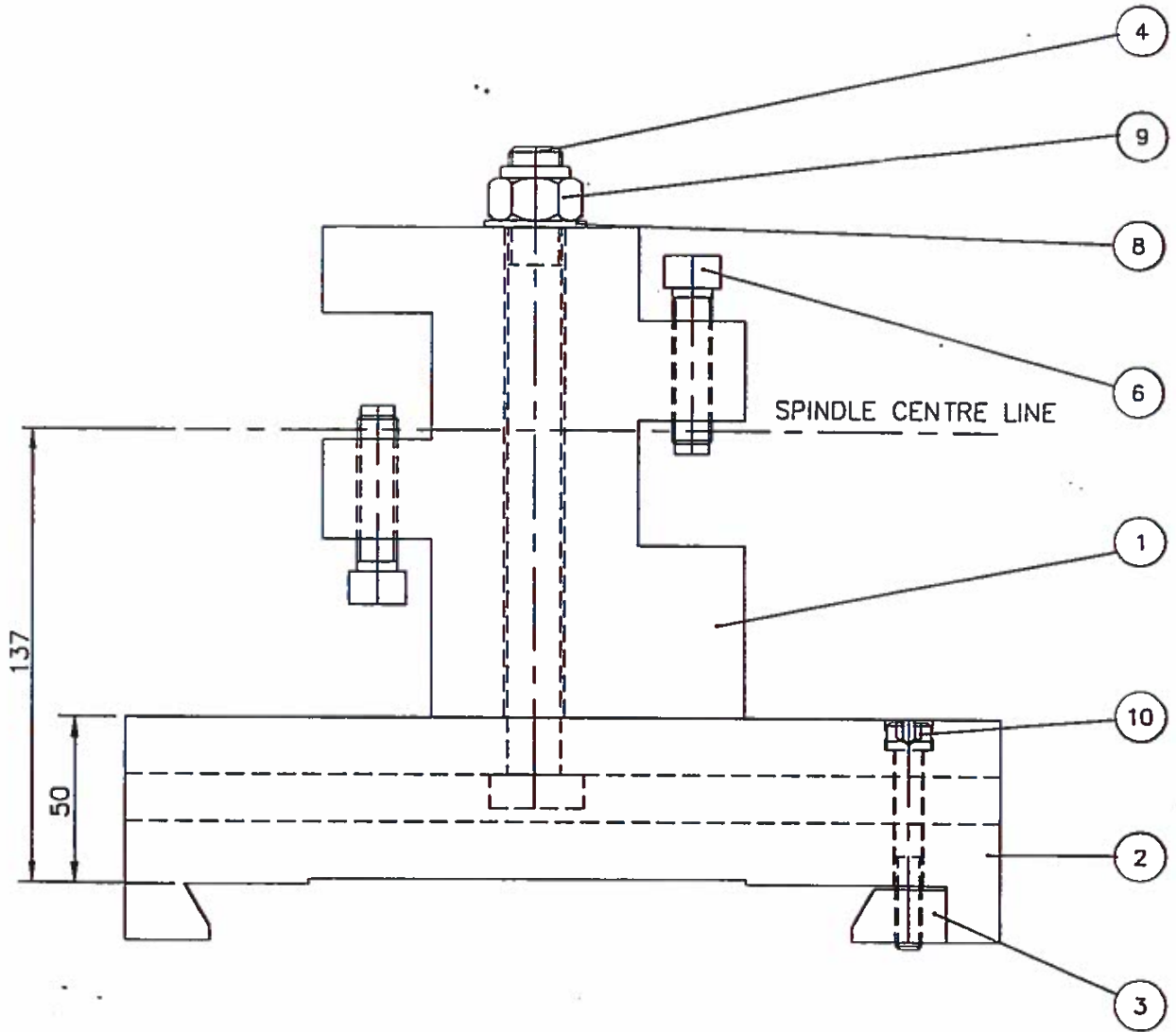

REAR TOOLPOST ASSEMBLY

A182 - 0712

Item No.	Description	Part No.
1	REAR TOOLPOST BODY	D831 - 0065
2	BASE PLATE	D565 - 1086
3	GIB STRIP	D345 - 0094
4	TEE BOLT	D048 - 0168
6	SQUARE HEAD SET SCREW M12x50	B170 - 0005
8	WASHER M16	B117 - 0013
9	NYLOC NUT M16	B147Y9027
10	HEXAGON SOCKET CAP HEAD SCREW M8x60	B163Y0061

NOTES

Customer Service, Parts and Sales, call 800-575-2843

info@harrisonlathe.com



www.harrisonlathe.com