



Harrison M300

13"x40" Geared Head Lathe



**ORIGINAL INSTRUCTIONS
AND
SPARE PARTS MANUAL**

M300 13"x25/40" Geared-head Lathes *The Ultimate Turning Machines*

A quality asset with outstanding features and performance

The only fully geared headstock centre lathe in the range, the M300 has features for easy control of its comprehensive capabilities. It has the power to deal with heavy metal removal, at the same time offering precision for fine tolerance turning.

Features

The M300 is a full-function machine capable of the entire range of turning operations, and through the available range of accessories its scope and versatility can be increased even further. Quality, reliability and response make it one of the most outstanding lathes of its kind especially in industry, the toolroom, training and secondary and tertiary education and it fully complies with all current CE safety legislation.

- Easy to understand headstock mounted speed, threading and feed charts
- Smooth power transmission through a twin vee belt drive and induction hardened and ground headstock gearing
- Large saddle and slide bearing areas for precision and long life
- Deep section top slide with dovetail guides and gib strip adjustment
- The combination box section cast iron bed and rigid steel base provides an incredibly strong structure
- A huge selection of accessories are available

Specifications

		M300
Centers	Height	167mm (6-3/16")
	Admit Between	635/1000mm (25/40")
Swing	Over Bed	330mm (13")
	Over Cross Slide	210mm (8-1/8")
	In Gap Diameter	480mm (19")
Spindle	Length	117mm (4-5/8")
	Bore	40mm (1-9/16")
	Nose	D1-4 Camlock
	Morse Taper in Nose	3 MT
Speeds	Number	12
	Range	40 to 2500rpm
Motor		2.2kW
Leadscrew	Diameter	28mm (1-1/8")
	Thread	6mm pitch or 4 TPI
Threads	Metric Pitches	45 from 0.2 to 14mm
	Imperial Pitches	52 from 2 to 56 TPI
	Module Pitches	18 from 0.3 to 3.5 MOD
	Diametral Pitches	18 from 8 to 56 DP
Feeds	Metric	21 from 0.3 to 2mm/rev
	Imperial	21 from .001 to .080in/rev
Cross Slide	Width	140mm (5-1/2")
	Travel	190mm (7-1/2")
Top Slide	Width	82mm (3-1/4")
	Travel	92mm (7-1/2")
Tailstock	Quill Diameter	42mm (1-5/8")
	Travel	110mm (4-5/16")
	Morse Taper	3 MT
Weight		710/790kg (1562/1738lbs)
Dimensions	L x W x H	1.68x.97x1.4m (66x38x55")
		2.13x1.02x1.45m (84x40x57")

M300

GEARED HEAD CENTRE LATHE

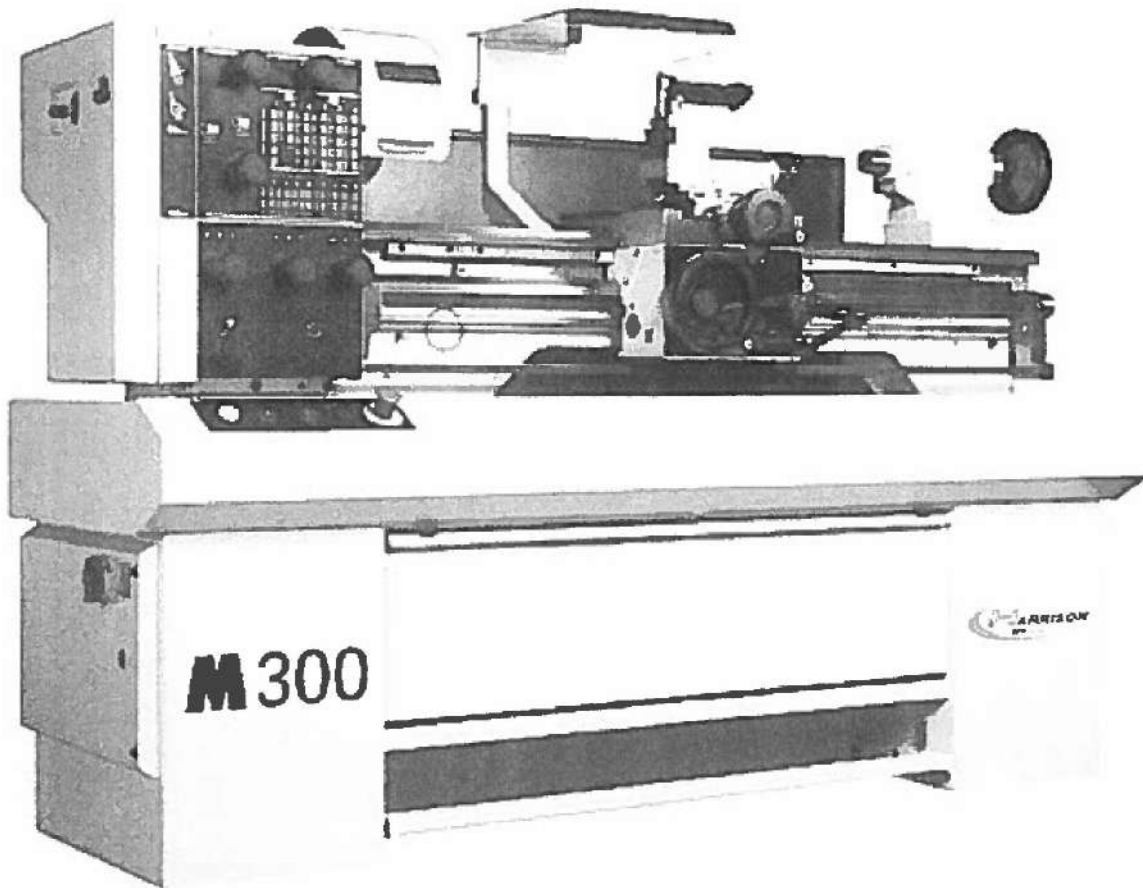

This manual applies only to the machine having the serial number shown; this is stamped on the front of the lathe bed at the tailstock end and **MUST** be quoted in all communications.

Machine Serial Number:

Year of Manufacture:

MANUFACTURED BY:

600 UK, 1 UNION WORKS, UNION STREET, HECKMONDWIKE,
WEST YORKSHIRE, ENGLAND, WF16 OHL



Blank page

Operating Safety	1
Machine Specification	11
Installation	13
General Arrangement and Foundation Plan	13
Installation Instructions	14
Lubrication Chart	16
Operation	17
Lathe Safety	17
Control Layout	18
Operating Instructions	19
Thread Cutting	22
Service and Maintenance	26
Maintenance Instructions	26
Parts Section	29
Parts Ordering Procedure	30
Spare Parts Index	31
Electrical Wiring Diagram	118

Blank page

HEALTH AND SAFETY - GUIDANCE NOTES

PLEASE READ CAREFULLY BEFORE OPERATION OF YOUR LATHE

OPERATOR SAFETY

These Lathes are fast, powerful machines which can be dangerous if used under improper circumstances. Read the following Health and Safety Guidance Notes and observe before and during the use of the machine.

HEALTH AND SAFETY AT WORK ACT 1974 (U.K. ONLY)

In accordance with the requirements of the Health and Safety at Work etc. Act 1974 this manual contains the necessary information to ensure that the machine tool can be operated properly and with safety. It is assumed that the operator has been properly trained, has the requisite skill and is authorised to operate the machine, or, if undergoing training, is under the close supervision of a skilled and authorised person.

Attention is drawn to the importance of compliance with the various statutory regulations which may be applicable, such as "The Protection of Eyes Regulations", It is further stressed that good housekeeping, common sense and the maintenance of good established work shop practice is essential.

Adequate information is also provided to enable the machine to be properly Serviced and maintained by persons with the necessary skills and authority.

ON MACHINES WITH VARIABLE SPEED DRIVE

NOTE THAT THESE MACHINES ARE DESIGNED TO ALLOW FAST AND EASY CHANGE OF THE SPINDLE SPEED. TAKE CARE TO ENSURE THAT THE WORK PIECE IS SECURE AND THE MAXIMUM SAFE SPEED FOR ANY OPERATION IS NOT EXCEEDED.

ALL MACHINES

BECAUSE OF THE POSSIBILITY OF BODILY CONTACT AND WHIPPING, ESPECIALLY WHEN SMALL DIAMETERS OF MATERIAL ARE USED, BAR STOCK MUST NOT, UNDER ANY CIRCUMSTANCES, BE ALLOWED TO EXTEND BEYOND THE END OF THE HEADSTOCK SPINDLE WITHOUT THE USE OF SPECIAL GUARDING AND ADEQUATE SUPPORT.

OPERATING SAFETY

OPERATING SAFETY PRECAUTIONS

- 1 Keep the machine and work area neat, clean and orderly.
- 2 Keep all guards and cover plates in place and all machine cabinet doors closed.
- 3 Never lay anything on the working surfaces of the machine, where it may foul with rotating or moving parts.
- 4 Do not touch or reach over moving or rotating machine parts.
- 5 ENSURE YOU KNOW HOW TO STOP THE MACHINE BEFORE STARTING IT
- 6 Do not operate the machine in excess of its rated capacity.
- 7 Do not wear rings, watches, ties or loose sleeved clothing.
- 8 STOP MACHINE IMMEDIATELY ANYTHING UNEXPECTED HAPPENS.
- 9 DO NOT interchange chucks or other spindle mounting items without checking for correct locking.
- 10 Do not use other workholding devices without checking for compatibility with 600UK Ltd and workholding manufacturer.
- 11 Check load capacity of revolving centres for current application.
- 12 Isolate machine when leaving it unattended.

OPERATING SAFETY

OPERATING HAZARDS

When using the machine be FULLY AWARE of the following operating hazards detailed under the following instructions:

METAL CUTTING FLUIDS

Cancer of the skin may be produced by continuous contact with oil; particularly with straight cutting oils, but also with soluble oils. The following precautions should be taken:

1. Avoid unnecessary contact with oil.
2. Wear Protective clothing.
3. Use protective shields and guards.
4. Do not wear oil soaked or contaminated clothing
5. After work thoroughly wash all parts of the body that have come into contact with oils.
6. Avoid mixing different types of oils.
7. Change oils regularly.
8. Dispose of oils CORRECTLY.

SAFE OPERATION OF LATHE CHUCKS

All workholding devices must be clearly marked indicating the maximum safe RPM. This must not be exceeded. It must be noted that the maximum RPM marking usually assumes ideal working conditions. Lower maximum speeds should be used typically for the following reasons:

They apply only to chucks in sound condition.

If a chuck has sustained damage, high speeds may be dangerous. This applies particularly to chucks with grey cast iron bodies wherein fractures may occur.

The gripping power required for any given application is not known in advance.

The strength of the component being gripped, the area of the grip, the balance of the workpiece etc. will all have a major effect on the safe maximum RPM that can be used.

OPERATING SAFETY

There is the possibility of the work piece becoming insecurely gripped due to the influence; of centrifugal force under certain conditions. The factors involved include:

- (a) Too high a speed for a particular application.
- (b) Weight and type of gripping jaws if non-standard.
- (c) Radius at which gripping jaws are operating.
- (d) Condition of chuck· inadequate lubrication.
- (e) State of balance.
- (f) The gripping force applied to the work piece in the static condition.
- (g) Magnitude of the cutting forces involved.
- (h) Whether the work piece is gripping externally or internally.

Careful attention must be paid to those factors. As they vary with each particular application, a manufacturer cannot provide specific figures for general use, the factors involved being outside his control.

OPERATING SAFETY

GENERAL PRINCIPLES CONCERNING OPERATOR SAFETY FOR ALL TURNING MACHINES

- 1 Do not grip a component with grease or oil on it.
Grip all components firmly.
Do not attempt to hold components that are too awkward or too difficult to hold.
Do not hold components that are too heavy for the machine.
Know how to hold components properly when lifting.
- 2 Be sure to clean oil or grease from hand tools, levers and handles.
Be sure there is enough texture on the surface of the hand tool or lever handle for proper safe hand contact.
- 3 Grip hand tools and lever handles firmly.
Always choose the proper hand tool and appropriate grip position on the lever handle.
Do not use hand tools or lever handles in an awkward position.
Do not apply excessive force.
- 4 Always use the recommended gripping position to grasp hand tools and lever handles.
- 5 Do not allow turning or hand tools to be caught in the chuck or other holding device.
- 6 Do not use broken, chipped or defective tools.
- 7 Be sure work piece cannot move in chuck or other holding device.
- 8 Beware of irregular shaped work pieces.
- 9 Beware of large burrs on work pieces.
- 10 Always select the correct tool for the job.
- 11 Do not run the machine unattended.
- 12 Do not use tools without handles.
- 13 Always support the work piece as necessary using chucks, steadies and centres.
- 14 Correctly locate tool in socket heads and screw slot.
- 15 Beware of obstructions that prevent complete tightening of screws - ensure screw is tight.
- 16 Do not rush work.
- 17 Never substitute the wrong size tools if the correct sized tool is not available or cannot be located in the shop
- 18 Do not move guards while lathe is under power.
- 19 Do not place hand or body in path of moving objects.
Beware of moving lathe parts that can fall.
Be aware of where you are moving your hand or body in relationship to the lathe.
Beware of holding a tool or other parts inserted in or attached to the chuck or work piece.

OPERATING SAFETY

Be aware of where you are moving your hand or body in relationship to the lathe.

Beware of holding a tool or other parts inserted in or attached to the chuck or work piece.

Be aware of hands or other parts of the body that may be in a position to be hit by a chuck or work piece.

- 20 Beware of accidentally moving levers, clutches (where applicable) or turning the power on.
- 21 Know the function of each and every control.
- 22 Never place hand on chuck or work piece to stop rotation of the spindle.
- 23 On machine with clutch drive make sure clutch is completely disengaged on stopping, and kept properly adjusted.
- 24 Make sure power has been turned off when lathe is unused for some time.
- 25 Allow chuck to stop before operating it.
- 26 Always check chuck area for chuck keys and loose items.
- 27 Never start spindle with chuck key in the chuck.
- 28 Do not allow distractions to interfere with lathe operations.
Do not operate lathe whilst talking.
- 29 Beware of lathe dangers when attending to other aspects of lathe operation, e.g. whilst operating tailstock.
- 30 Beware of loose clothing near the rotating parts of the lathe.
- 31 Beware of loose hair near the rotating parts of the lathe.
- 32 Beware of performing another operation while in close proximity to rotating parts on the lathe.
- 33 Always attend to filing and deburring operations.
Always pay attention to file or deburring tools close to the chuck.
Files and deburring tools may catch on chuck.
- 34 Beware of clutch (where applicable) position when jogging the spindle to different positions for gauging .
- 35 Beware of hands resting on clutch levers.
- 36 Be sure lathe is in neutral position when placing gauges on components gripped in the chuck.
- 37 Be sure motor (on machines with clutches) is not running when using gauges on the machine.
- 38 Always wear protection before operating the lathe.
Always wear the correct protection before operating the lathe.
Never remove protection for even a short time when operating the lathe.
Wear protective devices correctly.
Know the correct way to wear protective devices.

OPERATING SAFETY

- 38 Always wear protection before operating the lathe.
Always wear the correct protection before operating the lathe.
Never remove protection for even a short time when operating the lathe.
Wear protective devices correctly.
Know the correct way to wear protective devices.
- 39 Beware of material flying from the lathes.
- 40 Keep protective guards at the point of operation.
Know how to set or attach protective guards properly.
Never use the wrong protective guard.
Know how to select the proper guards.
- 41
- a. When the chuck and work piece are in motion never reach over, under or around a work piece to make an adjustment
 - b. Never reach over, under or around a work piece to retrieve anything.
 - c. Beware of where you leave your tools during set up.
 - d. Never reach over, under or around work piece to move hand tool/lathe to another position.
 - e. Never reach over, under or around the work piece to tighten a lathe part.
 - f. Never reach over, under or around work piece to remove swarf.
- 42 Know the proper procedure for applying loads.
Never apply force from an awkward position.
- 43 Never mount a work piece too large for the lathe.
- 44 Never mount a work piece too large for the operator to handle.
- 45 Use the equipment necessary for handling work pieces.
- 46 Never apply undue force on the accessory or control lever.
- 47 Secure all work pieces.
- 48 Secure all jaws, nuts, bolts and locks.
- 49 Always use the correct equipment
- 50 Never take cuts beyond machine's capability.
- 51 Never use excessive force in polishing, filling and deburring.
- 52 Always use the proper hand tool to remove swarf
Never hurry to remove swarf.
Beware of swarf wrapped around the chuck or work piece.
- 53 Never change gears by moving them with your hands.
- 54 Beware of tools/lathe parts falling on controls.

OPERATING SAFETY

CHUCKS AND CHUCK GUARDS

The lathe is supplied with a fully interlocked chuck guard which is suitable for use with the standard chucks normally supplied with the machine.

The chuck guard must be in the fully closed position before the spindle is permitted to run.

For safe operating practices always ensure that chuck jaws do not extend beyond the outside diameter of the chuck (as interference with chuck guards may occur)

Maximum chuck diameters for this machine are:

3 jaw chucks - 160mm diameter

4 jaw chucks - 200mm diameter

DO NOT run chucks at speeds in excess of those marked on the chuck itself.

DO NOT mount chucks larger than those noted above, as this may result in damage to the machine.

DO NOT run a chuck with nothing gripped in the jaws.

The company has no liability for any damage/injury caused by the above conditions being ignored.

FACEPLATES

In the event of a faceplate being used on the machine the normal chuck guard must be removed from its mounting and if deemed necessary by the user alternative safe guarding facilities provided which are appropriate to the particular situation.

This can only be determined on a case by case basis when using faceplates and is therefore the responsibility of the user.

TAILSTOCK

DO NOT over-extend tailstock during use.

Tailstock barrel should not be wound beyond the red ring on the barrel, as this makes it unsafe to use.

A warning label is present on the tailstock.



Accidents at Metalworking Lathes using Emery Cloth

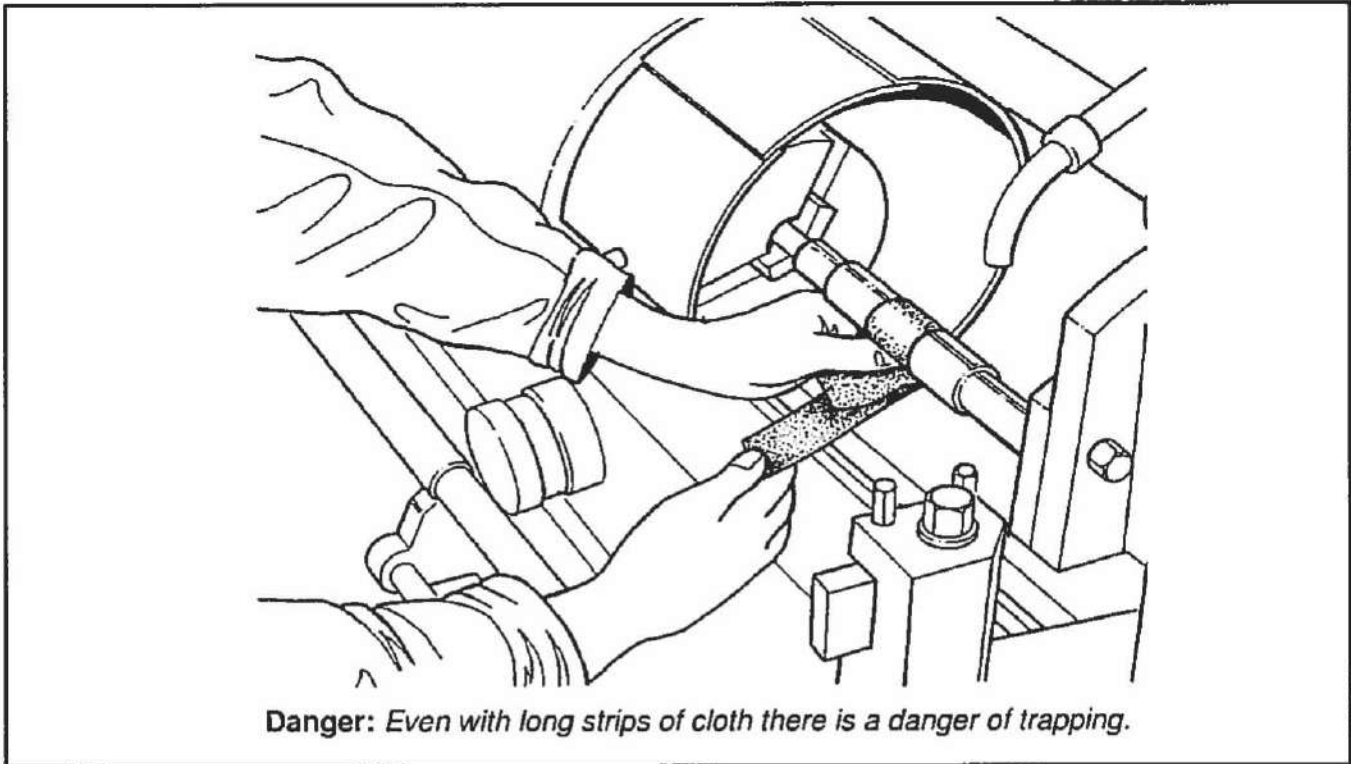

Hazards

A high proportion of all accidents at metalworking lathes involve the use of emery cloth and result in injuries such as broken and, occasionally, amputated fingers. Emery cloth is used to deburr, polish or size a wide range of cylindrical, tapered and threaded metal components while they are rotating in lathes.

Most accidents happen when each end of a strip of emery cloth is held in separate hands and passed around the back of the component being finished. If the cloth is wrapped around the fingers and/or becomes snagged on the component while it is tightly gripped, then a serious injury is the likely result

Precautions

Emery cloth should NEVER be used at CNC lathes. Employers should assess the need to use emery cloth on components rotating in a lathe.

Such operations may not be necessary if :

- (a) The finish being sought is only cosmetic. For such finishes the component may be held in one hand and polished by emery cloth held in the other. Alternatively a finishing belt or machine may be used;
- (b) A sizing operation can be successfully performed either by turning or by further operations in a dedicated polishing, finishing or grinding machine.

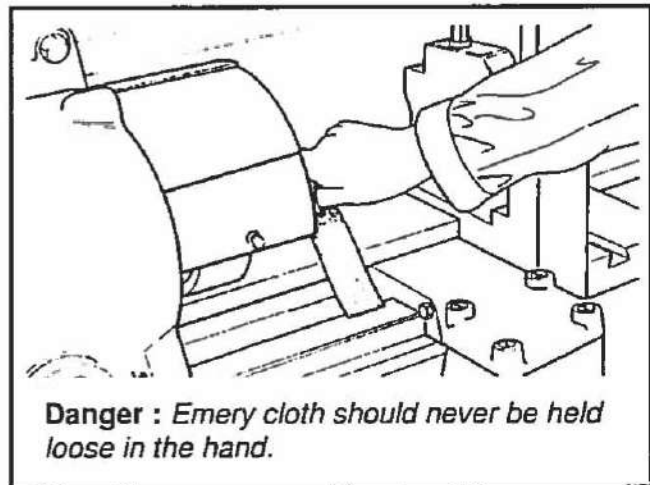

OPERATING SAFETY

If the required tolerance is only achievable by the use of emery cloth against rotating components, then the emery cloth should be applied using either:

- (a) a backing board of good quality wood;
or
- (b) a tool post onto which the emery cloth may be placed;
or
- (c) a 'nutcracker' consisting of two backing boards which are lined with emery cloth and joined at end and shaped so that they may encompass the surface to be finished;
or
- (d) hand-held, abrasive-impregnated wire brushes.

Where none of the above methods is reasonably practicable and it is necessary to use emery cloth for polishing the outside diameters of components, the emery cloth should be used in long strips with one end passed beneath the component.

Force should be applied by pulling both ends of the cloth upwards, never allowing the cloth to go slack or to wrap around either the operator's finger or the components.

For polishing the ends of components, only very short lengths or pads of cloth should be used which are incapable of causing entanglements.

Gloves should never be worn when polishing is being carried out.

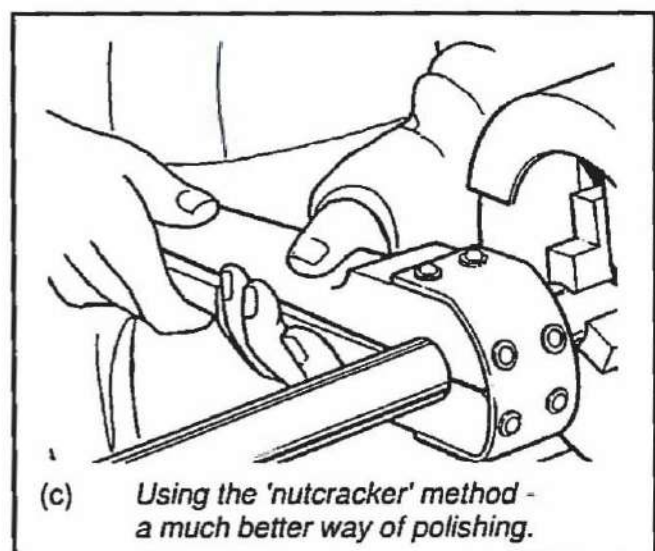
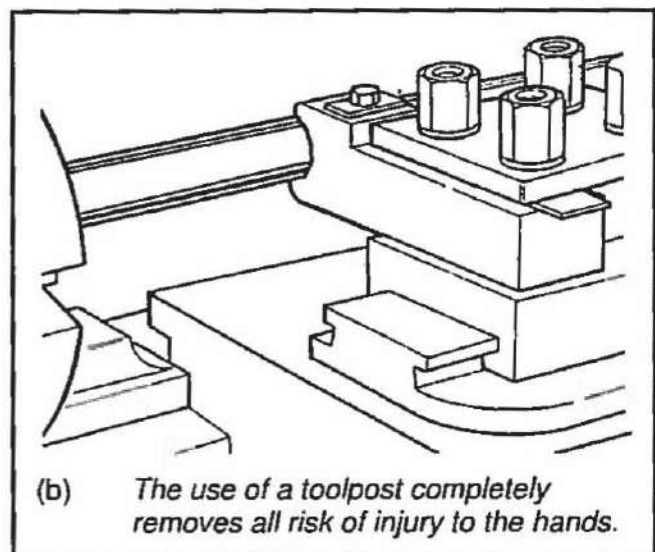
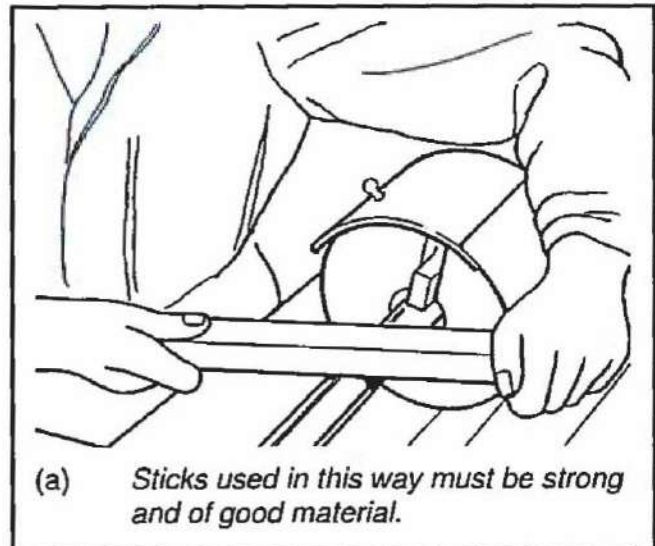

MACHINE SPECIFICATION

330mm (13") swing CENTRE LATHE

630mm MODEL - 630mm (25") between centres
 1000mm MODEL - 1000mm (40") between centres

This machine is manufactured to British metric standards throughout and is available in two bed lengths - each with either gap or straight bed versions.

A left or right hand apron handwheel and other Metric or Imperial drive screws (together with the appropriate dials) are optional variations.

Centres

Height	167mm (6.6")
Distance between	635mm (25") 1000mm (40")

Swing

Over Bed	300mm (13")
Over cross-slide	210mm (8.25")
In gap	480mm (19")
Width in front of faceplate	115mm (4.6")

Spindle

Bored to pass	40mm (1.6")
Nose type	D1-4" Camlock
Morse taper in NOSE	No.5 M.T.
Morse taper in bush	No.3 M.T.

Speeds

Number	12
Progression Ratio	1.45
Range	40 - 2500rpm

Motor (main)

	2.2kW (3 HP)
--	--------------

(1500rpm @50 Hz)

Leadscrew

Diameter	28mm (1.1")
Thread	6mm pitch or 4 TPI

Threads

39 Metric pitches	from 0.2 to 14mm
39 Imperial pitches	from 2 to 56 TPI
18 Module pitches	from 0.3 to 3.5 MOD
18 Diametral pitches	from 5 to 56 DP

Feeds

16 Metric (R10 Series)	from 0.03 to 2mm/rev
16 Imperial (R10 Series)	from 0.001 to 0.080 in/rev

Cross feeds = Approximately half longitudinal values

Cross Slide

Width	140mm (5.5")
Travel	190mm (7.5")

Top Slide

Width	82mm (3.25")
Travel	92mm (3.6")
Tool section	16 x 20mm (0.6" x 0.75")

Tailstock

Quill diameter	42mm (1.6")
Travel	110mm (4.3")
Morse taper	No.3 M.T.
Set over	±12mm (0.5")

Weight

630mm (25") m/c	583kg (1288lb)
1000mm (40") m/c	685kg (1512lb)

Coolant Tank capacity

630mm (25") m/c	20ltr
1000mm (40") m/c	25ltr

For other dimensions see foundation plan

Shipping Data	Gross Weight	Packing Case Dimensions		
		L	W	H
25" centres (630mm)	762kg (1680lb)	1.7m	0.94m	1.47m
40" centres (100mm)	889kg (1960lb)	2.08m	0.94m	1.47m

Illustrated or specified data is not binding in detail. The manufacturers reserve the right to modify design, specification and price without notice

MACHINE SPECIFICATION

NOISE LEVEL

The maximum noise level at the operators position (Fig.1) is within 85 dB(A) and the maximum mean noise level is within 85 dB(A).

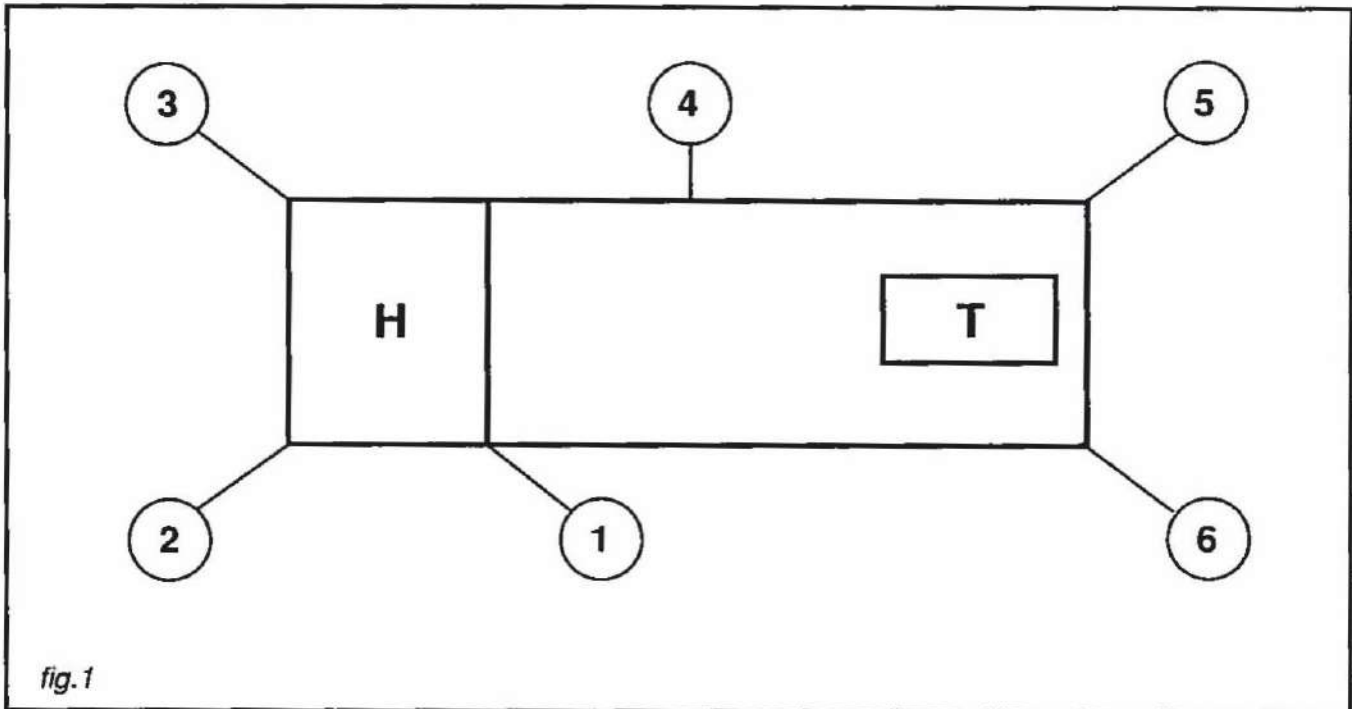

NOTE:

The operators position is position 1 and the mean is taken from the readings at all 6 positions.

The conditions of measurement are with the spindle running at top speed, with a standard chuck fitted, with no feed engagement.

These measurements are in accordance with BS4813: 1972

INSTALLATION

GENERAL ARRANGEMENT AND FOUNDATION PLAN

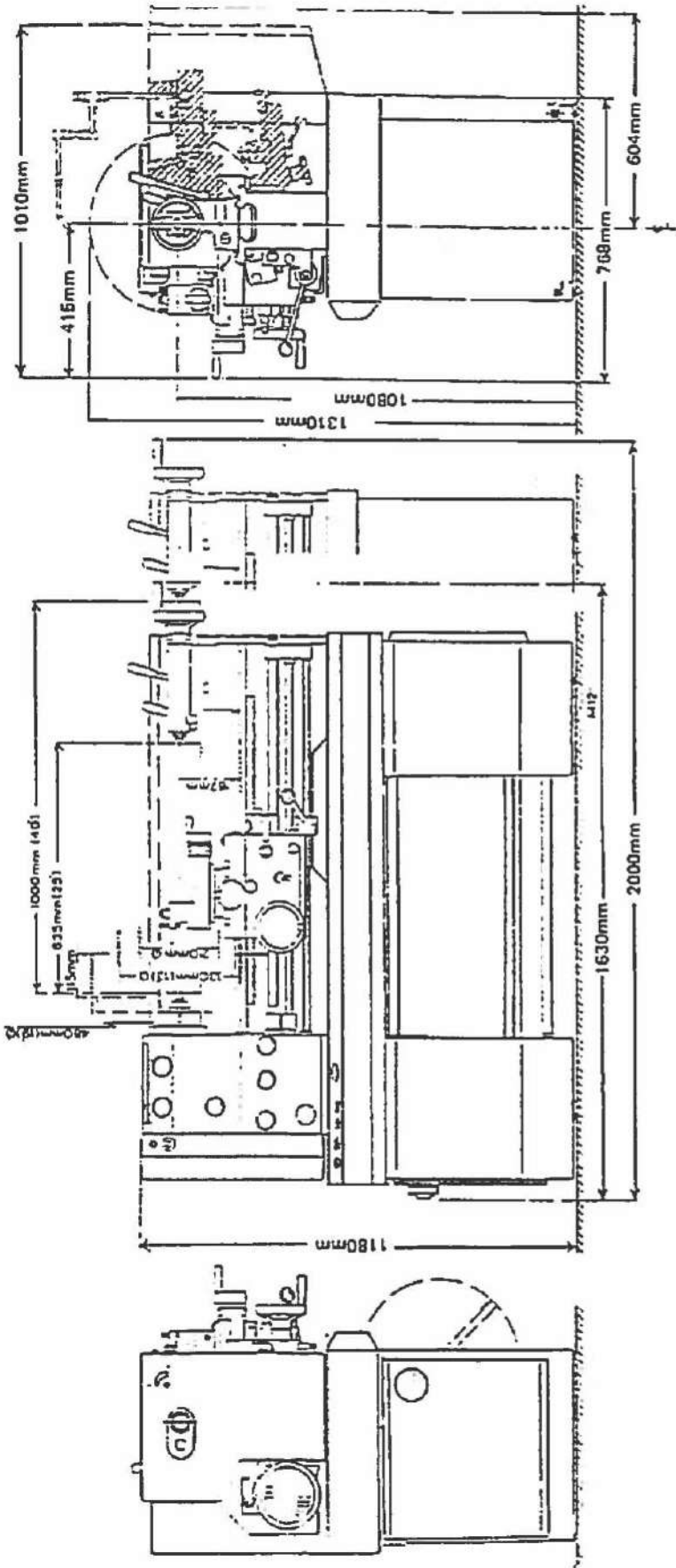

NOTE: 4 X M16 Bolts and Locknuts Supplied

A - M16 tapped holes
B - 18mm Dia. holes

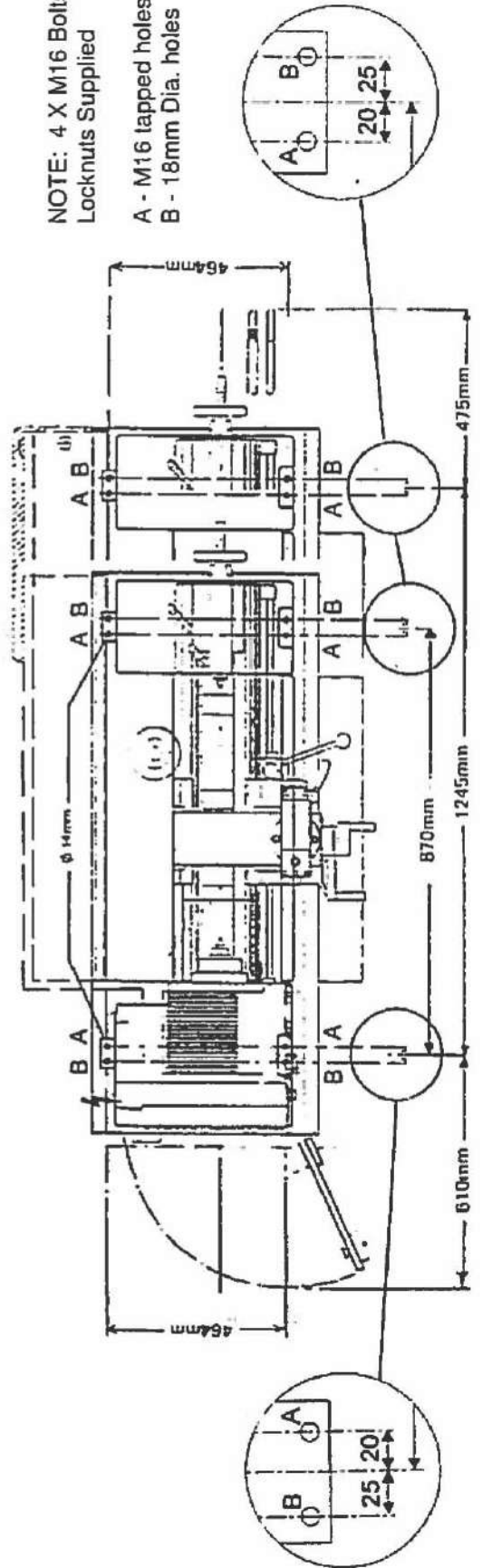

INSTALLATION

LIFTING

The approximate weights of the machine are:

630 mm model (630mm/25" between centres) – 583kg (1285 lb).

1000 mm model (1000mm/40" between centres) – 685kg (1512lb).

The machine should be lifted using a B985-0019, 2 tonne x 1 metre webbing sling. The sling should be used in the choked position on the bed- web nearest the headstock.

Note: The protective sleeve on the sling should be in contact with the web. The machine can be lifted with the splash guard on, but the carriage and the tailstock assemblies displaced (as dispatched) towards the tail end of the bed to give an equilibrium condition on the lifting hook.

CLEANING

Bright surfaces are coated with an anti- corrosive compound dispatch and this must be completely removed using white spirit or paraffin (Kerosene) before operating the controls or moving the slides. **DO NOT USE CELLULOSE SOLVENTS.** Oil the bright surfaces and slideways **AFTER CLEANING** (see lubrication diagram - page 16).

SITING THE MACHINE

The following points should be considered when choosing the site for the machine:

- a. The ground must be suitable for the machine foundations. It is recommended for efficient operation of the machine that it be mounted on steel plates (8) on a concrete or a stone base of 300mm thick on a firm sub- structure.
- b. The machine must not be positioned near any other machinery causing abnormal vibrations, e.g. pressers, guillotines, or near welding and high frequency equipment.
- c. Ensure adequate space is provided around the machine for all ancillary services, e.g. work loading, swarf removal, maintenance, etc.
- d. The ideal ambient temp is 20°C, however, a range from 10°C/30°C can be accommodated.
- e. Ensure that high voltage electrical cables are not in the proposed area.

POSITIONING

Locate the machine on a solid foundation allowing sufficient area for operation and maintenance access. (See Floor plan - page 13).

The Lathe may be used when free standing, but for maximum performance it should be bolted down.

1. Free standing. Position the machine on its foundation and adjust each of the four levelling screws to take an equal share of weight. Then using an engineer's precision level on the bed ways make further adjustments for level conditions.
2. Fixed installation. Position the machine over four 12 mm (1/2") diameter foundation bolts, set to suit the base. (See Floor plan - page 13).

Accurately level the Machine, then tighten the foundation bolts evenly to avoid distortion and finally re- check for level conditions.

ELECTRIC SUPPLY

Power should be supplied through an external fused isolator. Recommended fuses being 25 amp for 220 volts supply and 16 amp for 380 to 440 volts supply. External wiring should be of a permanent character and be undertaken by a competent electrician. Electrical entry is at the rear left hand end of the cabinet. (See Floor plan - page 13).

Line connections should be to the isolator terminals and substantial earth continuity conductor must be connected to the earth terminal on the panel. (See Electrical Wiring diagram at rear of this manual).

Main spindle rotation must be anti-clockwise (looking from tailstock) for a downward movement of the spindle control lever. Interchanging two line connections should rectify wrong direction of rotation.

LUBRICATION CHECKS

(refer to lubrication diagram - page 16)

Ensure that the headstock, gearbox and apron are filled to the relevant level oil sight windows, operate the centralised slideway lubrication system by pulling and releasing the knob at the bottom corner of the apron and oil the cross- slide nut, dials and changewheel stud etc. through the appropriate oil nipples using the oil gun provided.

RUNNING-IN

For optimum bearing life and performance it is recommended that high spindle speeds be avoided during the initial life of the machine.

Alternatively a running- in procedure should be adopted as follows:

Make a low feed rate selection and run the machine:

- light for 3 hours at 540rpm
- then for 2 hours at 800rpm
- then for 1 hour 1200 rpm
- then for 1/2 hour at 1700 rpm

INSTALLATION

LUBRICATION DIAGRAM

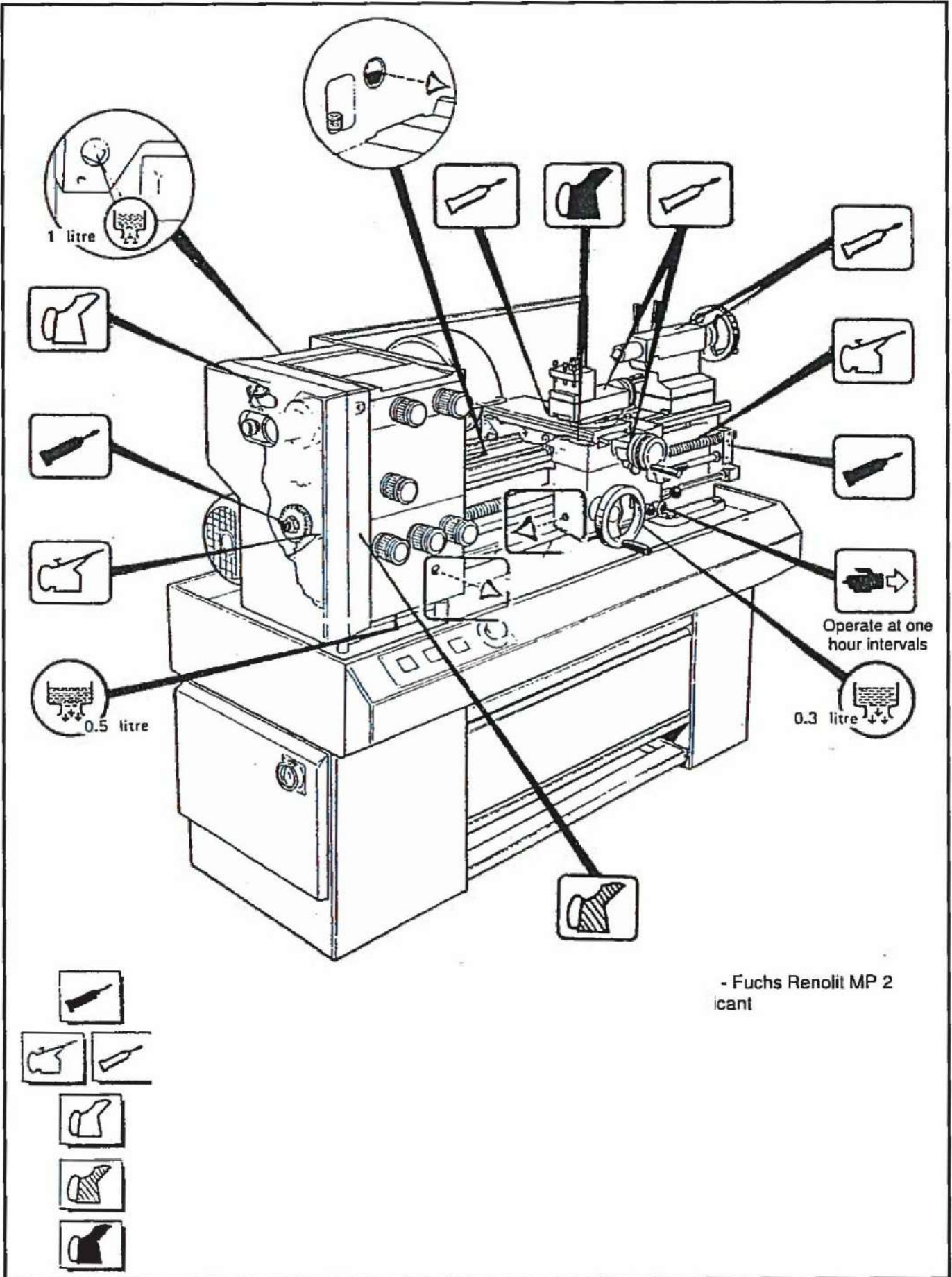

OPERATION

Before attempting to start the machine read carefully the lathe operating instructions on pages 17 to 25 of this manual.

LATHE SAFETY

In the interests of safety please read the Operator Health and Safety Guidance Notes at the beginning of this manual.

Some of the key points are:

1. Ensure you know how to stop the machine before starting it.
2. Stop machine immediately anything unexpected happens.
3. Ensure speeds, feeds and depths of cut are compatible with the component and the holding devices.
4. Do not touch tooling, chuck or work piece when spindle is revolving.
5. Wear and utilise suitable protective clothing and equipment.

OPERATION

CONTROL LAYOUT

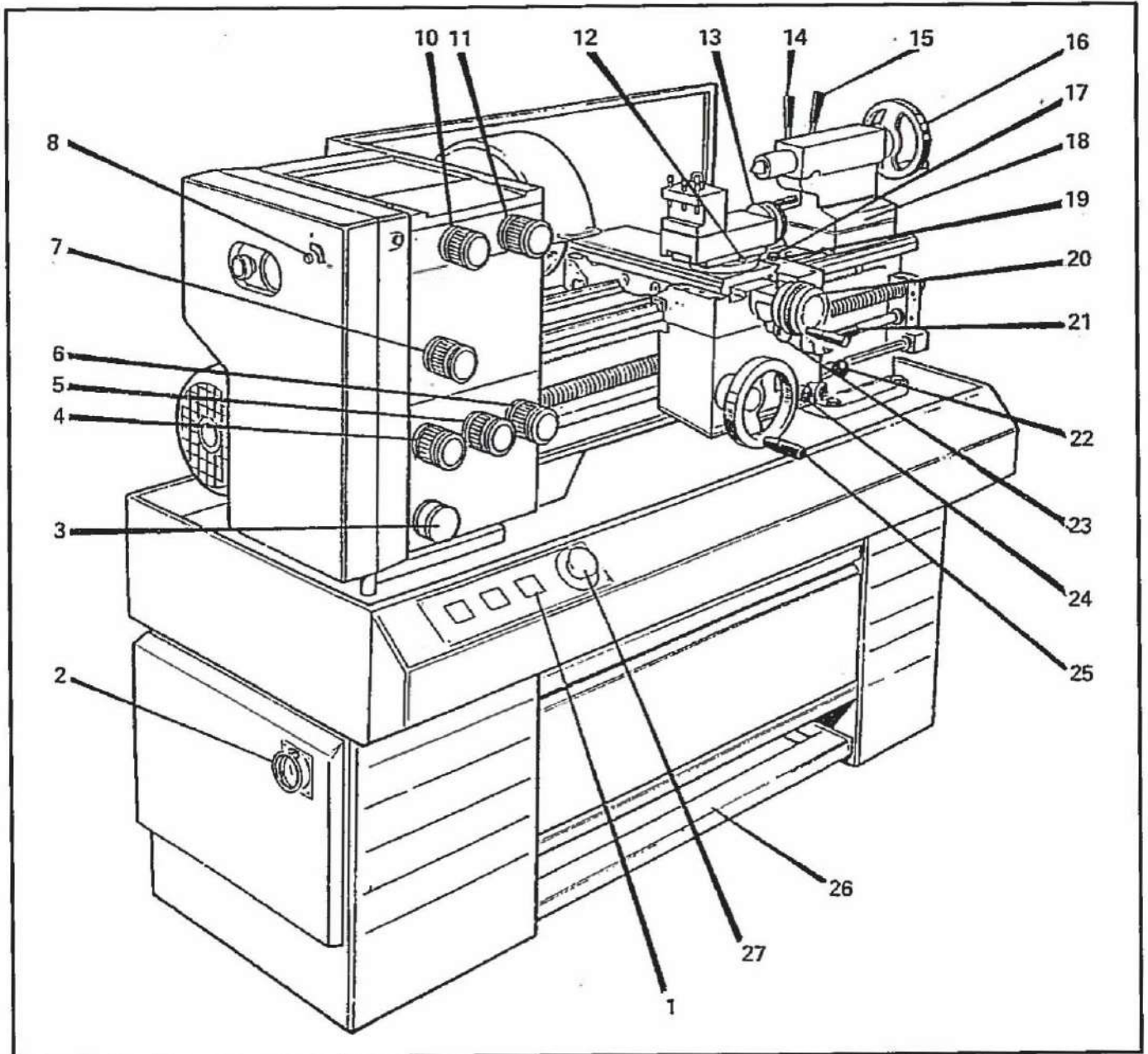

- 1. COOLANT PUMP STARTER
(when fitted)
- 2. MAINS ISOLATOR
- 3. FEED SELECTION DIAL
- 4. FEED SELECTOR HANDLE
- 5. FEED SELECTOR HANDLE
- 6. FEED SELECTOR HANDLE
- 7. FEED DIRECTION SELECTOR
- 8. INTERLOCK SWITCH
- 9. NOT USED

- 10. SPEED SELECTOR
- 11. SPEED SELECTOR
- 12. TOP SLIDE LOCK
- 13. TOP SLIDE TRAVERSE
HANDLE
- 14. QUILL LOCK
- 15. TAILSTOCK CLAMP
- 16. QUILL TRAVERSE
HANDWHEEL
In R H side of cross-slide
- 17. CROSS-SLIDE LOCK

- 18. TAILSTOCK SET-OVER SCREW
- 19. CARRIAGE LOCK
- 20. CROSS TRAVERSE HANDLE
- 21. THREADCUTTING ENGAGEMENT
- 22. SPINDLE CONTROL LEVER
- 23. FEED AXIS SELECTOR
- 24. FEED ENGAGE
- 25. LONGITUDINAL TRAVERSE
HANDWHEEL
- 26. BRAKE PEDAL
- 27. EMERGENCY STOP

OPERATION

STARTING THE MACHINE **

1. Ensure the lubrication has been carried out in accordance with the lubrication diagram.
2. Check that the spindle control lever (22) is in the central (STOP) position, the feed engage lever (24) and thread cutting lever (21) are in the disengaged position and that the changewheel cover is firmly secured in place.
3. Select - Feed axis - i.e. cross or longitudinal by means of the apron push – pull knob (23).
Select - Direction of feed – by means of the headstock lower selector handle (7)
Select - *Feed rate - by referring to the charts on the headstock and selecting (in the sequence listed) the appropriate positions on the gear box selector dial (3) and handles (4), (5) and (6) (engagement of the feed gears may be assisted by turning the main spindle)
Select - *Spindle speed - by means of the selector handles (10) and (11)

NOTE: THE SPINDLE SPEED SELECTORS ARE TO BE PUSHED IN BEFORE TURNING AND THAT SPEED SELECTIONS ARE TO BE MADE ONLY WHEN THE SPINDLE IS STATIONARY.

(Engagement of the drive gears may be assisted by manually turning the spindle).

4. Switch on the electrical supply at the mains isolator (2) which is the red knob at the L.H end of the cabinet.
5. Start the spindle in the direction of rotation required by lifting (FOR REVERSE) or lowering (FOR FORWARD) the "gated" spindle control lever (22) on the apron.
6. Start and stop the feed motion as required by means of the feed engage lever (24).

NOTES:

* Feed selections from the charts automatically disengage the leadscrew drive at the gearbox (i.e. by calling for selector position X) and for minimum wear the thread indicator dial should be disengaged by swinging the pinion out of mesh with the leadscrew when not in use.

** See installation instructions (RUNNING IN) if starting machine for first time

STOPPING THE MACHINE

The machine may be stopped in the following ways:

Return the spindle control lever (22) to its central (STOP) position.

OR

Depress the full length foot brake pedal (26)

OR

Press the emergency stop push- button (27).

OPERATION

OPERATIONAL NOTES

CHUCKS - USE ONLY HIGH SPEED TYPES

FACEPLATES - NOTE MAXIMUM SPEEDS
1200 rpm for 300 mm (12") dia.
and 800 rpm for 460 mm (18") dia.

COARSE FEED RANGE - i.e. (when secondary changewheels are inverted to give 88/44T) SHOULD NOT BE USED WITH SPINDLE SPEEDS ABOVE 540 RPM.

Micrometer dials are direct readings for work piece diameter reduction on the cross-slide) and are of the friction grip type for easy index settings.

Longitudinal traverse handwheel (25) may be disengaged by pulling it away from the apron face.

Tailstock set over adjustment, is provided in the form of socket screws (18) mounted in each side of the tailstock body, a similar but 'Location screw' is fitted in the rear face of the body.

Set over adjustment is made as follows:
Unclamp the tailstock (lever 15)
Slacken the rear 'location screw' half a turn.

Then, alternatively one set-over screw set and tighten the other until the required setting is achieved.

Tighten the rear 'location screw' and re-clamp the tailstock.

DO NOT over-extend tailstock during use.

Tailstock barrel should not be wound beyond the red ring on the barrel, as this makes it unsafe to use.

A warning label is present on the tailstock.

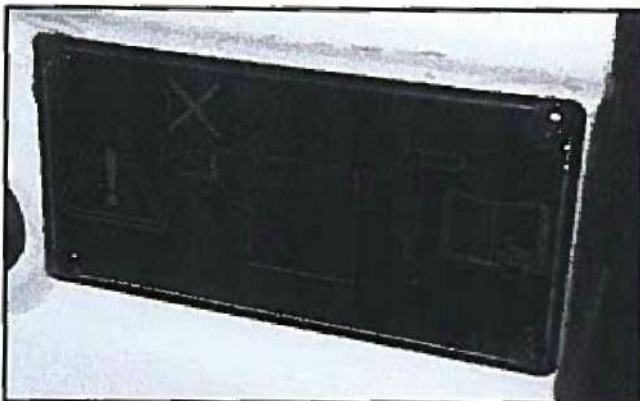

OPERATION

CHUCKS AND CHUCK MOUNTING

When fitting chucks or faceplates, first ensure that the spindle nose and chuck tapers are clean; mount the chuck and ascertain that the cams lock in the correct position. When mounting a new chuck it may be necessary to reset the cam lock studs (A).

To do this, remove the caphead locking screws (B) and set each stud so that the scribed ring (C) is flush with the rear face of the chuck and with the circular scallop in line with the locking screw hole (see inset),

Now remount the chuck or faceplate on the spindle nose and tighten the six cams in turn. When correctly tightened the cam lock line on each cam should be between the two "V" marks on the spindle nose.

If any of the cams do not tighten fully within those marks, remove the chuck or faceplate and re-adjust the stud as indicated in the diagram. Once a chuck has been correctly fitted it may be stamped to align with the spindle reference mark for subsequent re-mounting in the same position.

WARNING

Only high speed chucks to be used with this machine.

Take careful note of speed limitations when using faceplates.

The small and large diameter faceplates (available as accessories) **MUST NOT** be used in the high spindle speed range.

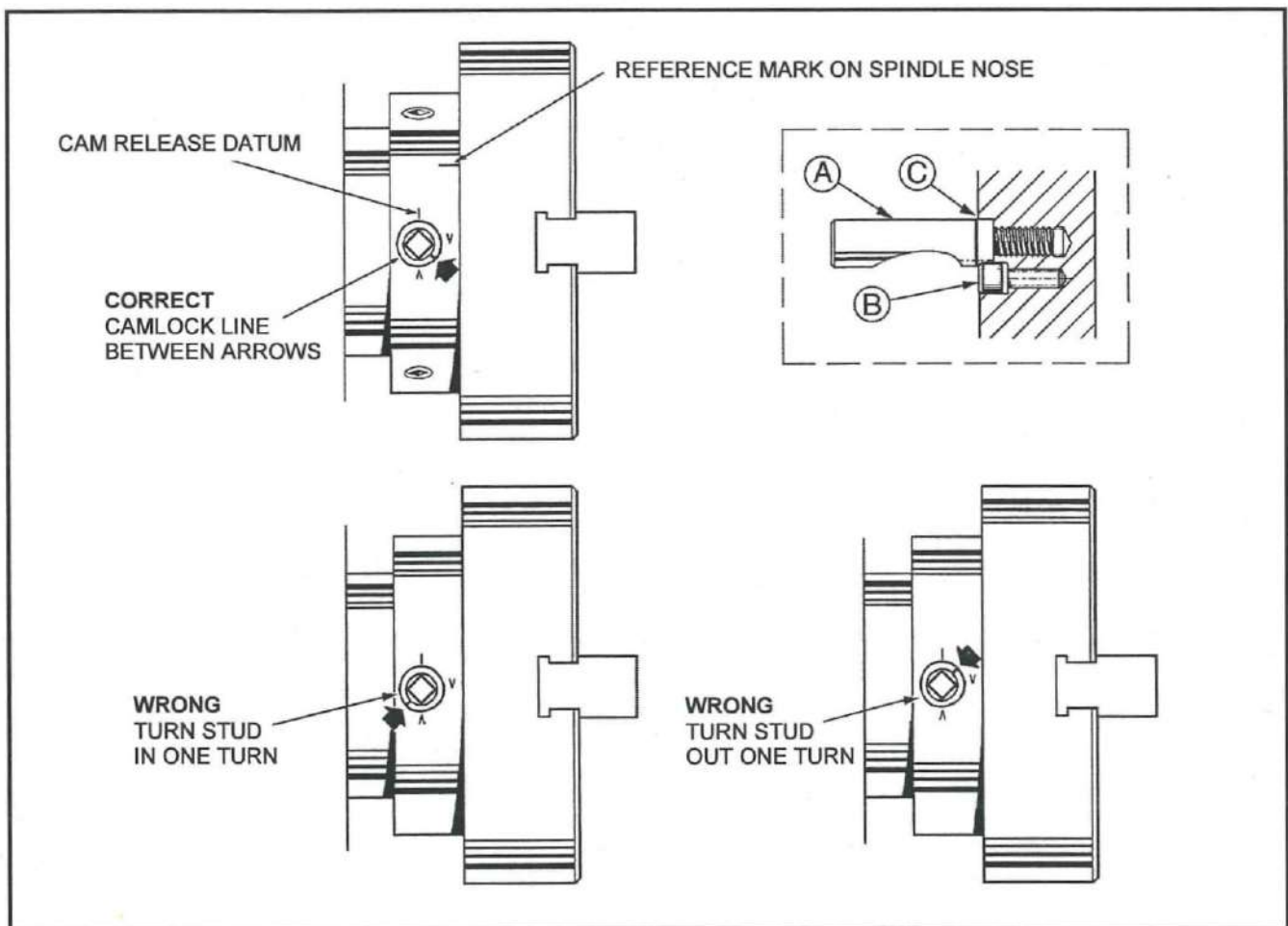

OPERATION

ins						mm					
F		F		G		F		F		G	
56	C8RY	18	C2SY	7	C8SY	.2	AT1W	1	AR3W	4	BS1W
52	C7RY	16	C1SY	6½	C7SY	.225	AT2W	1.1	AR4W	4.5	BS2W
48	C6RY	14	C8TY	6	C6SY	.25	AT3W	1.2	AR6W	5	BS3W
46	C5RY	13	C7TY	5½	C4SY	.3	AT6W	1.25	BS3W	5.5	BS4W
44	C4RY	12	C6TY	5	C3SY	.35	AT8W	1.3	AR7W	6	BS6W
40	C3RY	11½	C5TY	4½	C2SY	.4	AS1W	1.4	AR8W	6.5	BS7W
36	C2RY	11	C4TY	4	C1SY	.45	AS2W	1.5	BS6W	7	BS8W
32	C1RY	10	C3TY	3½	C8TY	.5	AS3W	1.75	BS8W	8	BR1W
28	C8SY	9	C2TY	3¼	C7TY	.55	AS4W	2	BR1W	9	BR2W
26	C7SY	8	C1TY	3	C6TY	.6	AS6W	2.25	BR2W	10	BR3W
24	C6SY			2¾	C5TY	.65	AS7W	2.5	BR3W	11	BR4W
23	C5SY			2¾	C4TY	.7	AS8W	2.75	BR4W	11.5	BR5W
22	C4SY			2½	C3TY	.75	BT6W	3	BR6W	12	BR6W
20	C3SY			2¼	C2TY	.8	AR1W	3.25	BR7W	13	BR7W
19	B2SY			2	C1TY	.9	AR2W	3.5	BR8W	14	BR8W

ins / ⌀		mm / ⌀					
F	G	F	G				
.001	AT1X	.005	AT1X	.03	AT1X	.12	AT1X
.0016	AT4X	.006	AT4X	.04	AT4X	.15	AT4X
.002	AT8X	.008	AT8X	.05	AT8X	.2	AT8X
.0025	AS1X	.010	AS2X	.06	AS1X	.25	AS2X
.003	AS4X	.012	BT1X	.08	AS4X	.3	BT1X
.0035	AS7X	.016	BT4X	.09	AS7X	.4	BT4X
.004	AS8X	.020	BT8X	.1	AS8X	.5	BT8X
.005	AR1X	.025	BS1X	.12	AR1X	.6	BS1X
.006	AR4X	.030	BS4X	.16	AR4X	.8	BS4X
.008	AR8X	.040	BS8X	.2	AR8X	1	BS8X
.010	BS8X	.050	BR2X	.25	BS8X	1.2	BR2X
.012	BR1X	.060	BR4X	.3	BR1X	1.5	BR4X
.016	BR4X	.070	BR6X	.4	BR4X	1.8	BR6X
.020	BR8X	.080	BR8X	.5	BR8X	2.0	BR8X

SPECIAL THREADS NOT SHOWN ABOVE MAY BE CALCULATED ON REQUEST

METRIC LEADSCREWS

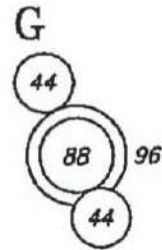
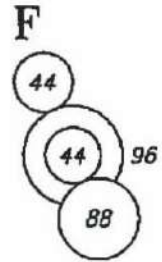

6mm

IMPERIAL LEADSCREWS

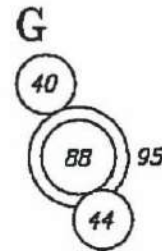
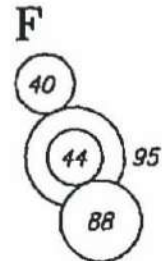

4TPI

OPERATION

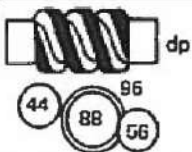
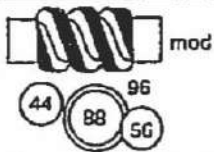
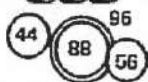
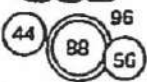
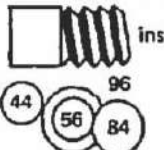
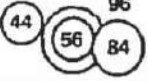
 <p>dp</p>			 <p>mod</p>		
<p>H</p> 			<p>H</p> 		
56 C8RY	24 C6SY	13 C7TY	.3 AT6W	.9 AR2W	2.25 BR2W
48 C6RY	22 C46Y	12 C6TY	.4 AS1W	1 AR3W	2.5 BR3W
40 C3RY	20 C3SY	11 C4TY	.5 AS3W	1.25 BS3W	2.75 BR4W
36 C2RY	18 C2SY	10 C3TY	.6 AS6W	1.5 BS6W	3 BR6W
32 C1RY	16 C1SY	9 C2TY	.7 AS8W	1.75 BS8W	3.25 BR7W
28 C8SY	14 C8TY	8 C1TY	.8 AR1W	2 BR1W	3.5 BR8W
 <p>ins</p>					
<p>I</p> 					
42 C8RY	27 C2RY	13% C2SY	6mm 1029		
39 C7RY	21 C8SY	10% C8TY			
33 C4RY	16% C4SY	7% C3TY			
30 C3RY	15 C3SY	6% C2TY			

METRIC LEADSCREWS

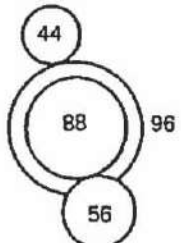

H

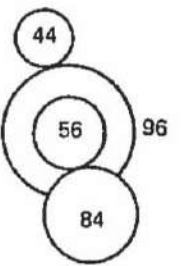

I

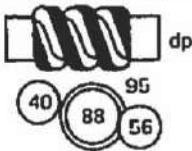
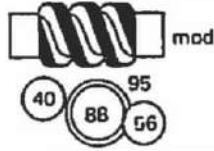
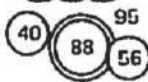

6mm

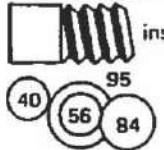
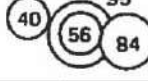
 <p>dp</p>			 <p>mod</p>		
<p>H</p> 			<p>H</p> 		
56 C8RY	24 C6SY	13 C7TY	.3 AT6W	.9 AR2W	2.25 BR2W
48 C6RY	22 C4SY	12 C6TY	.4 AS1W	1 AR3W	2.5 BR3W
40 C3RY	20 C3SY	11 C4TY	.5 AS3W	1.25 BS3W	2.75 BR4W
36 C2RY	18 C2SY	10 C3TY	.6 AS6W	1.5 BS6W	3 BR6W
32 C1RY	16 C1SY	9 C2TY	.7 AS8W	1.75 BS8W	3.25 BR7W
28 C8SY	14 C8TY	8 C1TY	.8 AR1W	2 BR1W	3.5 BR8W
 <p>ins</p>					
<p>I</p> 					
42 C8RY	27 C2RY	13% C2SY	4TPI 1025		
39 C7RY	21 C8SY	10% C8TY			
33 C4RY	16% C4SY	7% C3TY			
30 C3RY	15 C3SY	6% C2TY			

IMPERIAL LEADSCREWS

H

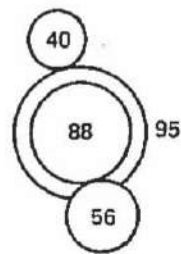

I

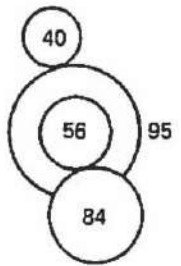





4TPI

SPECIAL THREADS NOT SHOWN ABOVE MAY BE CALCULATED ON REQUEST

OPERATION

THREAD CUTTING CHART

 mm			 ins			 mod		 dp			
0.2	AT1WF	2	BR1WF	2	CT1YG	14	CT8YF	0.2	AT1WH	8	CT1YH
0.225	AT2WF		BT1WG	2.25	CT2YG		CR8YG	0.225	AT2WH	9	CT2YH
0.25	AT3WF		AS3WG	2.5	CT3YG	14.25	BT1YJ	0.25	AT3WH	10	CT3YH
0.275	AT4WF	2.2	AS4WG	2.75	CT4YG	15	CS3YJ	0.275	AT4WH	11	CT4YH
0.2875	AT5WF	2.25	BR2WF	2.875	CT5YG	16	CS1YF	0.2875	AT5WH	11.5	CT5YH
0.3	AT6WF		BT2WG	3	CT6YG	16.5	CS4YJ	0.3	AT6WH	12	CT6YH
0.325	AT7WF	2.3	AS5WG	3.25	CT7YG	18	CS2YF	0.325	AT7WH	13	CT7YH
0.35	AT8WF	2.4	AS6WG	3.5	CT8YG		CS6YJ	0.35	AT8WH	14	CT8YH
0.4	AS1WF	2.5	BR3WF	4	CS1YG	19	BT1YF	0.4	AS1WH	16	CS1YH
0.45	AS2WF		BT3WG	4.5	CS2YG	19.5	CS7YJ	0.45	AS2WH	18	CS2YH
0.5	AS3WF	2.6	AS7WG	4.75	BT1YG	20	CS3YF	0.5	AS3WH	20	CS3YH
	BT1WF	2.75	BR4WF	5	CS3YG	21	CS8YJ		BT1WH	22	CS4YH
0.55	AS4WF		BT4WG	5.5	CS4YG	22	CS4YF	0.55	AS4WH	23	CS5YH
0.5625	BT2WF	2.8	AS8WG	5.75	CS5YG	23	CS5YF	0.5625	BT2WH	24	CS6YH
0.575	AS5WF	2.875	BT5WF	6	CS6YG	24	CS6YF	0.575	AS5WH	26	CS7YH
0.6	AS6WF		BT5WG		CT1YJ	26	CS7YF	0.6	AS6WH	28	CS8YH
0.625	BT3WF	3	BR6WF	6.5	CS7YG	27	CR2YJ	0.625	BT3WH	32	CR1YH
0.65	AS7WF		BS6WG	6.75	CT2YJ	28	CS8YF	0.65	AS7WH	36	CR2YH
0.6875	BT4WF	3.2	AR1WG	7	CS8YG	30	CR3YJ	0.6875	BT4WH	40	CR3YH
0.7	AS8WF	3.25	BR7WF	7.5	CT3YJ	32	CR1YF	0.7	AS8WH	44	CR4YH
0.71875	BT5WF		BT7WG	8	CT1YF	33	CR4YJ	0.7185	BT5WH	46	CR5YH
0.75	BT6WF	3.5	BR8WF		CR1YG	34.5	CR5YJ	0.75	BT6WH	48	CR6YH
0.8	AR1WF		BT8WG	8.25	CT4YJ	36	CR2YF	0.8	AR1WH	52	CR7YH
	AT1WG	3.6	AR2WG	8.625	CT5YJ		CR6YJ	0.8125	BT7WH	56	CR8YH
0.8125	BT7WF	4	BS1WG	9	CT2YF	39	CR7YJ	0.875	BT8WH		
0.875	BT8WF		AR3WG		CR2YG	40	CR3YF	0.9	AR2WH		
0.9	AR2WF	4.4	AR4WG		CT6YJ	42	CR8YJ	1	BS1WH		
	AT2WG	4.5	BS2WG	9.75	CT7YJ	44	CR4YF		AR3WH		
1	BS1WF	4.6	AR5WG	10	CT3YF	46	CR5YF	1.1	AR4WH		
	AR3WF	4.75	CR8WG		CR3YG	48	CR6YF	1.125	BS2WH		
	AT3WG	4.8	AR6WG	10.5	CT8YJ	52	CR7YF	1.15	AR5WH		
1.1	AR4WF	5	BS3WG	11	CT4YF	56	CR8YF	1.1875	CR8WH		
	AT4WG	5.2	AR7WG		CR4YG			1.2	AR6WH		
1.125	BS2WF	5.5	BS4WG	11.5	CT5YF			1.25	BS3WH		
1.15	AR5WF	5.6	AR8WG		CR5YG			1.3	AR7WH		
	AT5WG	5.75	BS5WG	12	CT6YF			1.375	BS4WH		
1.1875	CR8WF	6	BS6WG		CR6YG			1.4	AR8WH		
1.2	AR6WF	6.5	BS7WG		CS1YJ			1.4375	BS5WH		
	AT6WG	7	BS8WG	13	CT7YF			1.5	BS6WH		
1.25	BS3WF	8	BR1WG		CR7YG			1.625	BS7WH		
1.3	AR7WF	9	BR2WG	13.5	CS2YJ			1.75	BS8WH		
	AT7WG	10	BR3WG					2	BR1WH		
1.375	BS4WF	11	BR4WG					2.25	BR2WH		
1.4	AR8WF	11.5	BR5WG					2.5	BR3WH		
	AT8WG	12	BR6WG					2.75	BR4WH		
1.4375	BS5WF	13	BR7WG					2.875	BR5WH		
1.5	BS6WF	14	BR8WG					3	BR6WH		
1.6	AS1WG							3.25	BR7WH		
1.625	BS7WF							3.5	BR8WH		
1.75	BS8WF										
1.8	AS2WG										

OPERATION

THREAD DIAL INDICATORS

METRIC THREADS ON METRIC LEADSCREW MACHINES

or

ENGLISH THREADS ON ENGLISH LEADSCREW MACHINES

For these threads it is recommended that the "thread indicator dial" be used – this allows the leadscrew nuts to be disengaged at the end of each screwcutting pass, provided that they re-engage in accordance with the char mounted on the face of the dial unit.

METRIC LEADSCREW MACHINES - METRIC THREADS ONLY.

The chart shows:

- In column 1. mm pitch to be cut
- In column 2. (*) The number of teeth in the 'pick off gear' arranged to mesh with the leadscrew, (this being selected from the stack, stored on the bottom of the dial spindle).
- In column 3. The dial numbers at which the leadscrew nuts may be engaged.

ENGLISH LEADSCREW MACHINES - ENGLISH THREADS ONLY.

The chart shows:

- In column 1. T.P.I to be cut.
- In column 2. Dial numbers at which the leadscrew nuts must be engaged.

ENGLISH THREADS ON METRIC LEADSCREW MACHINES

or

METRIC THREADS ON ENGLISH LEADSCREW MACHINES.

For these threads the leadscrew nuts are kept engaged throughout the cutting of any one thread. This involves reversing the whole drive by means of the 'spindle control lever' (24) at each end of screwcutting pass whilst at the same time relieving or increasing the cut as required. (Threads 'A' may also be cut by this method).

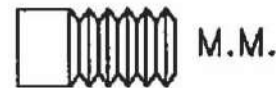
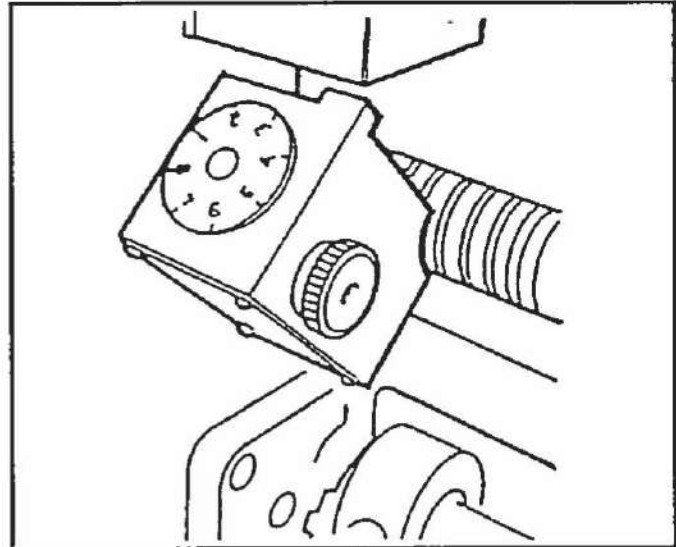

*		*	
.225	18 15	4	16 1-8
.25	16 1-8	4.5	18 15
.75	16 1-8	5	20 1357
1	16 1-8	5.5	22 15
1.25	20 1357	6	16 18
1.5	16 1-8	7	14 15
1.6	16 1357	8	16 1357
1.75	14 15	9	18-15
2	16 1-8	10	20 1357
2.5	20 1357	11	22 15
3	16 1-8	12	16 1-8
3.5	14 15	14	14 14



2	1-8	9	1357	24	1-8
2½	15	10	1-8	26	1-8
2¾	1	11	1357	27	1357
3	1357	11½	15	28	1-8
3¼	1	12	1-8	30	1-8
3½	15	13	1357	32	1-8
4	1-8	14	1-8	36	1-8
4½	15	16	1-8	40	1-8
5	1357	18	1-8	44	1-8
6	1-8	19	1357	48	1-8
7	1357	20	1-8	56	1-8
7½	15	22	1-8		
8	1-8				

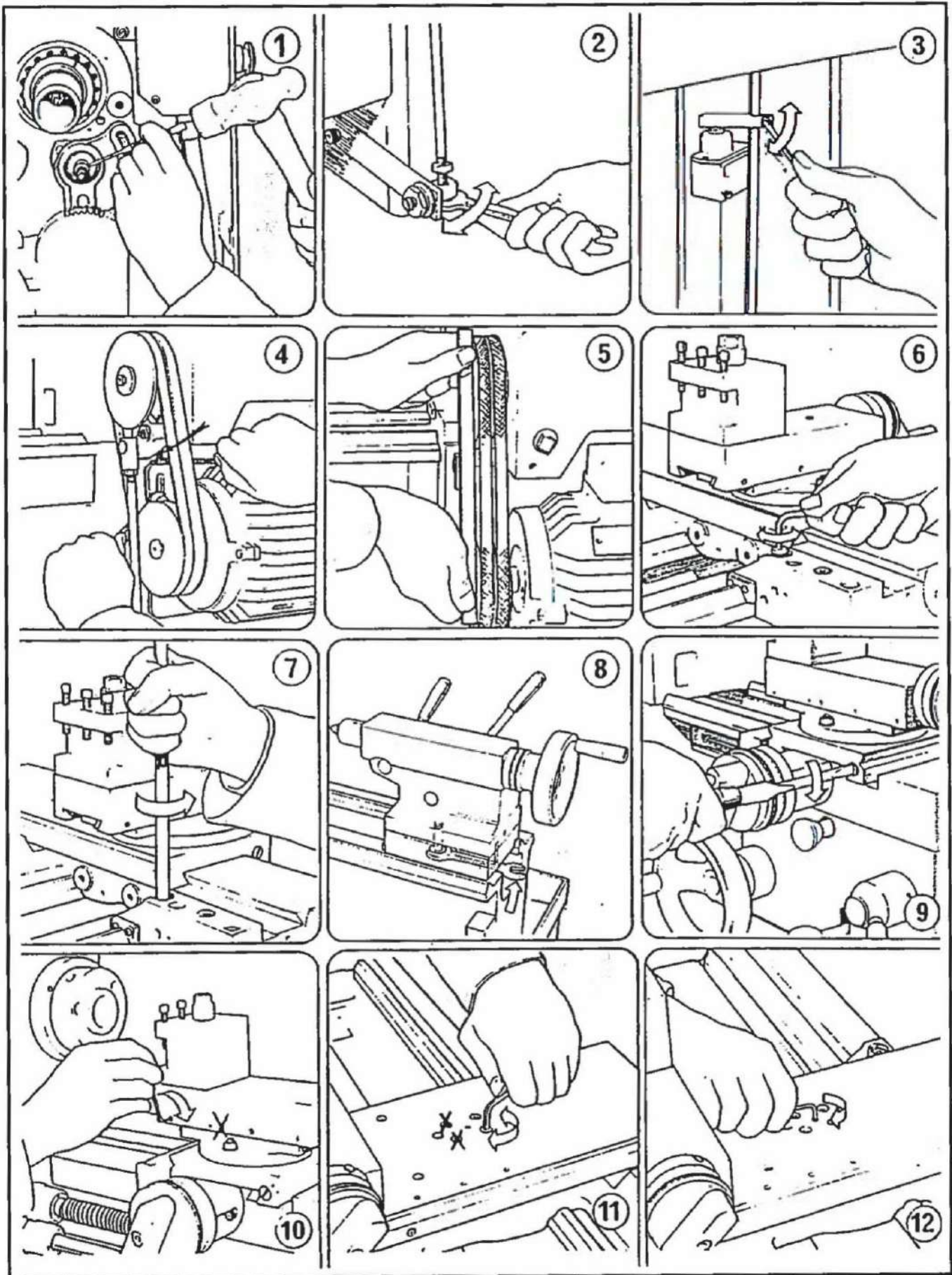

SERVICING AND MAINTENANCE

CHANGEWHEEL SHEAR PIN (fig. 1)

A protection against accidental overlap in the end gear train is provided in the form of a shear pin fitted in the splined sleeve on the top changewheel shaft. In the event of a replacement being necessary a 4mm (5/32") diameter x 20mm (3/4") long mild steel pin should be fitted as follows:

Remove the hexagon nut, washer and changewheel, pull off the splined sleeve and remove the broken pin parts from both sleeves and shaft. Fit new pin.

NOTE: the pin acts in single shear and will only enter the sleeve from the 'big hole' side.

BRAKE ADJUSTMENTS (fig. 2 and 3)

Adjustment for wear on the break pad (which is mounted on the headstock pulley) is made at the pivot connection between the foot brake pedal and the vertical link rod. This is readily accessible from the rear of the machine where adjustment is made by turning the two locknuts on the link rod. A limit switch is mounted on the cabinet higher up the link rod and a slight re-positioning of the contact block may be necessary after adjustment from break pad wear.

NOTE: The function of the limit switch is to cut out the motor drive when the brake pedal is operated, i.e. the plunger should be depressed when the brake pedal is in its free position and released at the moment the brake pedal is operated.

DRIVE BELTS (fig. 4 and 5)

Access to the vee belts is gained by removal of the rear splash guard (when fitted) and the sheet metal drive covers.

The drive motor is bolted to a slotted mounting plate which is vertically adjustable on the rear face of the bed. This is clamped by three hexagon head screws. Belt tension adjustment is achieved adjusting the two vertical screws against the top edge of the mounting plate.

It is important that when making adjustments a straight edge be placed across the face of each pulley to ensure that correct alignment is maintained.

SADDLE STRIPS (fig. 6 and 7)

Wear on the rear and the front saddle strips may be accommodated by adjustment of the retaining sleeves located in the top face of the saddle; two for the rear and one for each of the front strips.

TAILSTOCK BED CLAMP (fig. 8)

The angular lock position of the bed clamp lever is adjusted by mean of the self locking hexagon headed bolt, located on the underside of the tailstock and between the bed ways.

CROSS-SLIDE (fig. 9)

Wear on the taper-gib strip may be adjusted for, by clockwise rotation of the slotted head screw on the front face of the cross-slide. The procedure being to first slacken the similar screw at the rear then re-tighten this after adjustment to clamp strip in new position.

TOP SLIDE (fig. 10)

Take up for wear on the top slide strip is by means of the four (self-locking) socket set screws in the front face of the top slide casting.

CROSS-SLIDE NUT (fig. 11 and 12)

Provision is made for the elimination of the backlash in the cross-slide nut, the procedure for adjustment being as follows:

Slightly release, only the rear pair of socket cap head screws in the top face of the cross-slide, turn the centre socket set screw in a clockwise direction as required then re-clamp the two rear cap screws. Care should be taken to avoid over adjustment, a 120° turn at the centre screw represents approximately 0.1mm (0.004") take up of backlash.

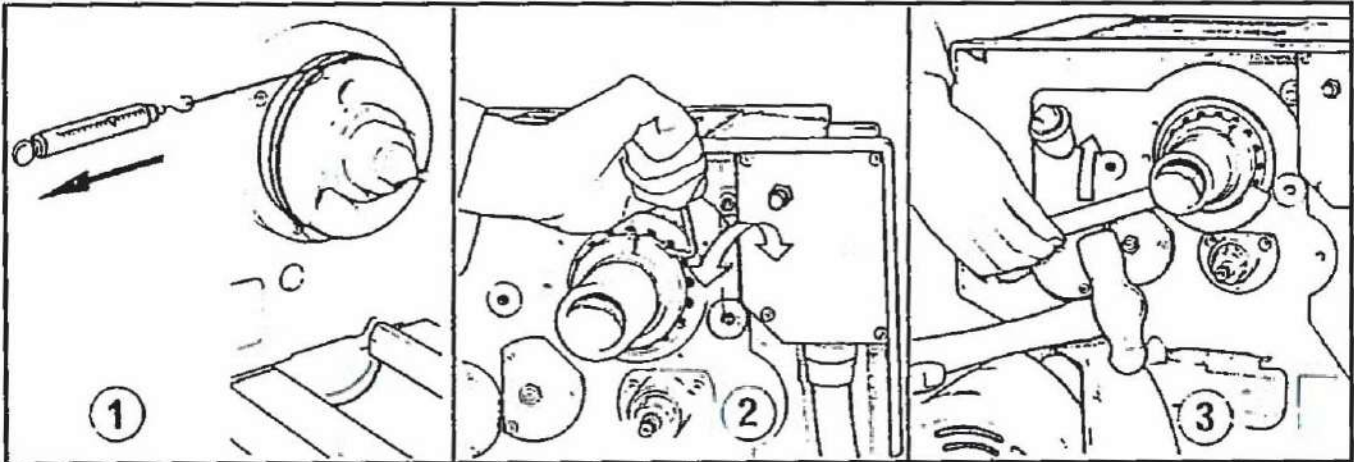

The spindle assembly is carefully set before despatch of the lathe from our works which should ensure a high standard of performance without the need for further attention.

THE USER IS ADVISED NOT TO DISTURB THIS SETTING DURING NORMAL US OF THE MACHINE AND TO CONSULT OUR SERVICE DEPARTMENT IN THE UNLIKELY EVENT OF A BEARING PROBLEM.

WHERE ADJUSTMENT IS UNDERTAKEN THEN IT IS ESSENTIAL THAT THE FOLLOWING PROCEDURES ARE STRICTLY COMPLIED WITH.

TO CHECK FOR CORRECT SETTING

Checks should be carried out with the headstock in a warm condition achieved by running at a spindle speed of 800rpm for approximately ten minutes.

The correct bearing torque setting is 0.9/1.1 Nm (8/10 in/lbs) and can be determined as follows:

Wrap a length of string approximately three turns around the body of the chuck (fig. 1).

To the free end of the string attach a light spring balance and pull gently until spindle commences to turn, continuing to apply a steady load just sufficient to maintain the spindle in motion and noting the steady load registered on the balance.

Example: Using a 160mm (6.5") chuck, the spring balance reading should be 1.14/1.36 kg (2.5/3 lbs)

BEARING ADJUSTMENT

remove end drive guard, change wheels, swing frame and rear bearing cover.

Release locking screw in bearing adjusting nut (fig.2). With a pin key adjust the nut as required, clockwise rotation to increase bearing load (fig.3). As over tightening will seriously impair the life of the bearings it is recommended that adjustment be made in increments not exceeding 3mm (1/8") measured on the nut periphery. After each incremental adjustment, the spindle should be run for a few minutes and bearing load rechecked as previously described..

SPARE PARTS SECTION

IMPORTANT WHEN ORDERING -

1. Quote component's Part Number and description, against each parts illustration for all component parts required.
2. Some parts are standard items which can generally be purchased locally - e.g. nuts, bolts, screws, washers, etc.

In such instances, the component description can be used to provide a suitable replacement.

3. Always quote the Lathe Serial Number in all parts orders or technical enquiries. This number is stamped into the lathe bed at the tailstock end.

NOTE : Part Numbers do not run consecutively in the Spare Parts section.

Parts Section

1

Quote:

Machine Serial Number

which will be found stamped into the front face of the bedways at the tailstock end.

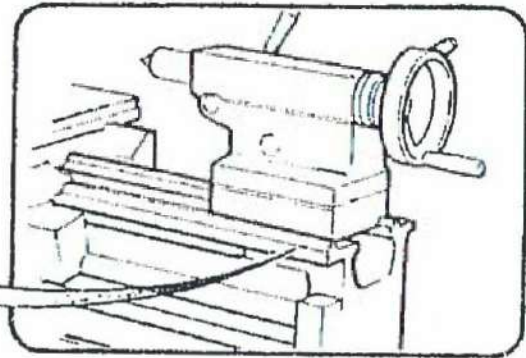

2

For Standard Machine Parts

Refer to the appropriate assembly and Quote the individual Part Numbers taken from the parts list, opposite the illustration, together with the Description and Quantity required.

For Additional Equipment and Attachments

Refer to the appropriate assembly and Quote the individual Part Numbers taken direct from the illustration.

Note: Quantity used, other than one, will be given in a circle following the Part Number.

Where Part Numbers change with Machine Bed length then the machine model number is given, vis.

630mm or 1000mm

Standard / Proprietary Parts (i.e. Parts that can be purchased from a local engineering supplier) may be identified by the "bracketed" letter code included in the Part number, and reference to the appendix at the end of this Manual will provide a full description of the items required.

CONTENTS

BED & CABINET	32
BRAKE & DRIVE ASSEMBLY.....	34
THIRD SHAFT SWITCH ASSEMBLY.....	38
CHANGEWHEEL GUARDS.....	40
HEADSTOCK.....	42
HEADSTOCK SELECTOR.....	50
GEARBOX ASSEMBLY.....	54
GEARBOX GEARS AND SHAFTS.....	58
APRON.....	64
APRON SHAFTS.....	68
APRON WORM GEARING.....	72
LUBRICATING OIL PUMP.....	76
THREAD DIAL INDICATOR.....	78
SADDLE ASSEMBLY.....	82
SLIDES ASSEMBLY.....	86
SHAFT, RACK AND BRACKET ASSEMBLY.....	90
TAILSTOCK ASSEMBLY.....	94
CHANGEWHEELS.....	98
INTERLOCKED CHUCK GUARD	102
ADDITIONAL EQUIPMENT SECTION.....	103
ELECTRICAL SECTION	118

BED AND CABINET ASSEMBLY

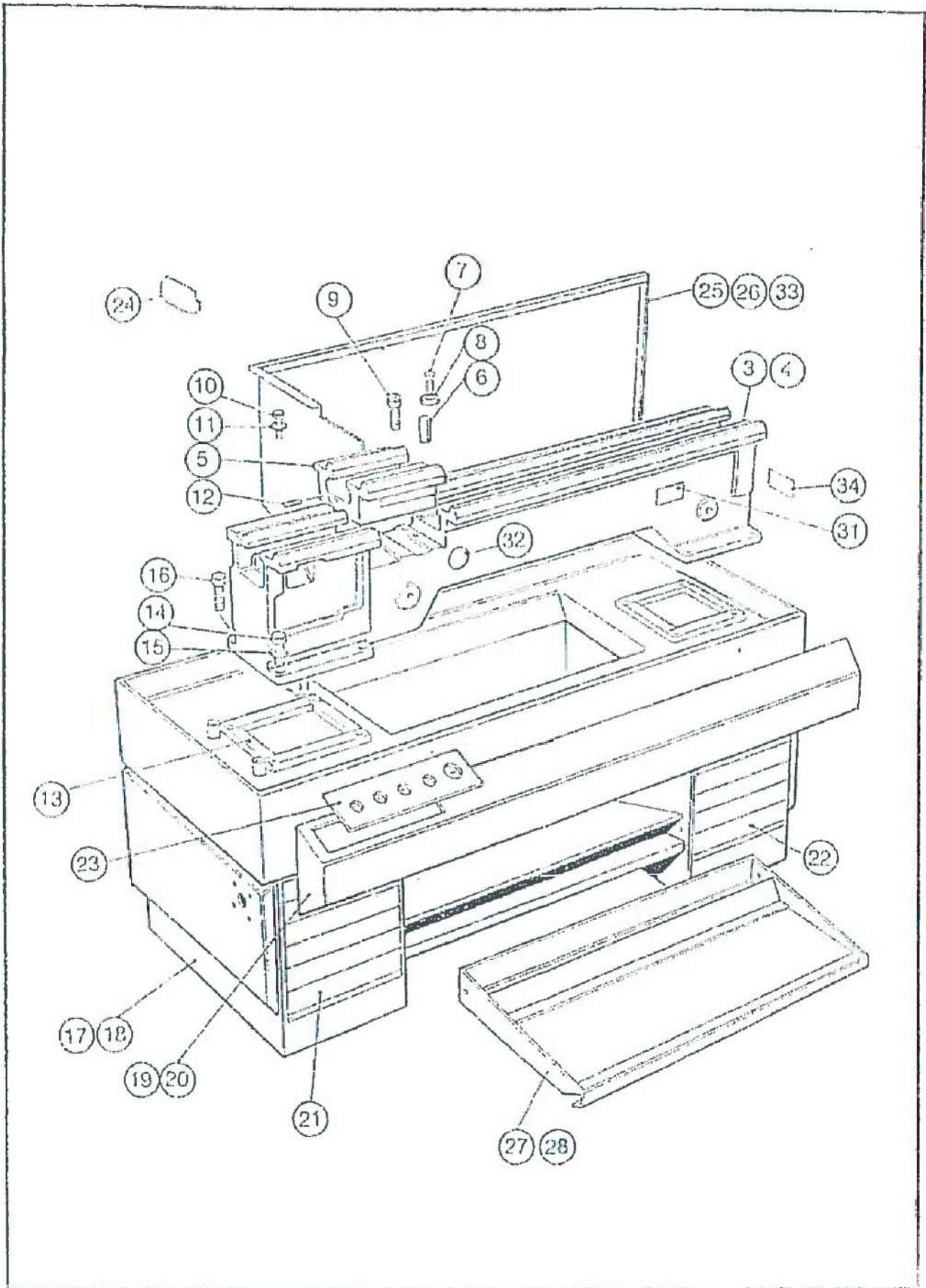

BED AND CABINET ASSEMBLY

ITEM	PART No.	DESCRIPTION	QTY
3	D045-0176J	BED, GAP, 25 in. LG	1
4	D045-0175J	BED, GAP, 40 in. LG	1
5	D850H8001	GAP PIERCE	1
6	FT-0960	PIN, TAPER	1
7	FS-0462	SCREW, M8 X 16 COUNTERSUNK SOCKET	1
8	D001H2093	WASHER	1
9	FS-0188	SCREW, M10 X 35 CAP HD SOCKET	2
10	FS-0636	SCREW, M10 X 25 HEX HD H/T	1
11	FP-0060	WASHER, M10	1
12	FS-0520	SCREW, M8 X 20 CUP POINT	1
13	D700H1010	STRIP, BED SUPPORT	4
14	FS-0608	SCREW, M12 X 45 HEX HD H/T	6
15	FP-0070	WASHER, M12	6
16	FS-0210	SCREW, M12 X 35 CAP HD	2
17	D042-0229	CABINET BASE, 25 in.	1
18	D042-0222	CABINET BASE, 40 in.	1
19	D346-1457	FACIA, 25 in.	1
20	D346-1421	FACIA, 40 in.	1
21	D537-1543	NAMEPLATE 'H ' LOGO	1
22	D537-1546	NAMEPLATE M300	1
23	NA-1207	NAMEPLATE-CONTROLS	1
24	D301H037.1/V	SWARF SHIELD	1
25	D346-1459	SPLASH GUARD, REAR, 25 in.	1
26	D346-1458	SPLASH GUARD, REAR, 40 in.	1
31	NA-0866	INDUCTION HARDENED BEDWAY PLATE	1
32	NA-4251	ISO METRIC THREAD LABEL	1
33	D410H033.1	BRACKET, SPLASH GUARD	2
34	D537-1169	NAMEPLATE 'H' LEGEND	1

BRAKE AND DRIVE ASSEMBLY

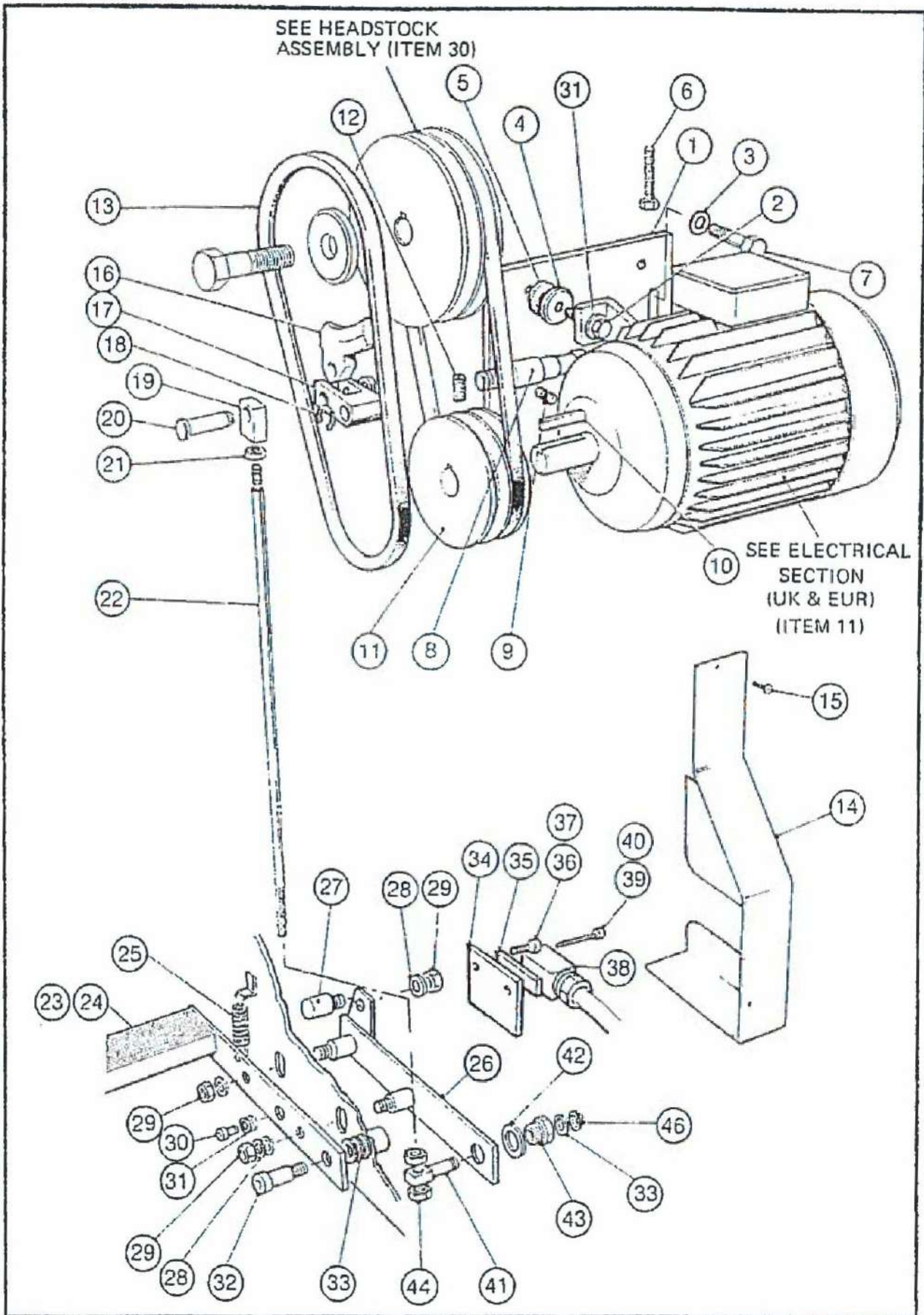

BRAKE AND DRIVE ASSEMBLY

ITEM	PART No.	DESCRIPTION	QTY	
1	D565-2799	BRACKET, MOTOR MOUNTING, UK, EUROPE, CANADA	1	
2	FS-0576	SCREW, M8 X 30 HEX HD	4	
2	FS-0578	SCREW, M8 X 35 HEX HD (USA ONLY)	3	
3	FP-0060	WASHER, M10	4	
4	GC-0070	SPACER, MOUNTING	4	
5	GE-0020	MOUNTING, ANTI VIBRATION	4	
6	FS-0874	SCREW, ADJUSTING, M8 X 50 SQ HD	2	
7	FS-0636	SCREW, M10 X 25 HEX HD	3	
8	D260H1007	SHAFT, MOTORING MOUNTING	1	
9	FS-0366	SCREW, M8 X 12 DOG POINT	1	
10	KA-0072	KEY, MOTORSHAFT, UK, EUROPE, CANADA	1	
10	KA-0212	KEY, MOTOR SHAFT, USA	1	
11	D031H6008	PULLEY DRIVE – UK & EUROPE	1	
11	D031H6009	PULLEY DRIVE-USA	1	
11	D031H6010	PULLEY DRIVE-CANADA	1	
12	FS-0502	SCREW, M6 X 12	1	
13	VA-0075	BELT, DRIVE	2	
14	D301H109.1	COVER, PULLEY MOTOR	1	
15	FS-0284	SCEW, M5 X 10 BUTTON HD	5	
		FOOT BREAK ASSEMBLY		
16	YQ-0010	BLOCK, BRAKE	1	
17	D810H2001	BRACKET , BRAKE	1	
18	RA-0410	CLIP, SPRINGFIX	2	
19	D800H1003	BLOCK, CONNECTING ROD	1	
20	D130H1004	PIN, PIVOT	1	
21	FS-0920	NUT, M8	1	
22	S2501C017	ROD, CONNECTING	1	
23	S2501C003	PEDAL, FOOTBREAK, 1000mm MACHINE	OR	1
24	S2501C004	PEDAL, FOOTBREAK, 635mm MACHINE		1
25	FR-0012	SPRING		2
26	S2501C032	BAR, BRAKE		1

(Contd)

BRAKE AND DRIVE ASSEMBLY

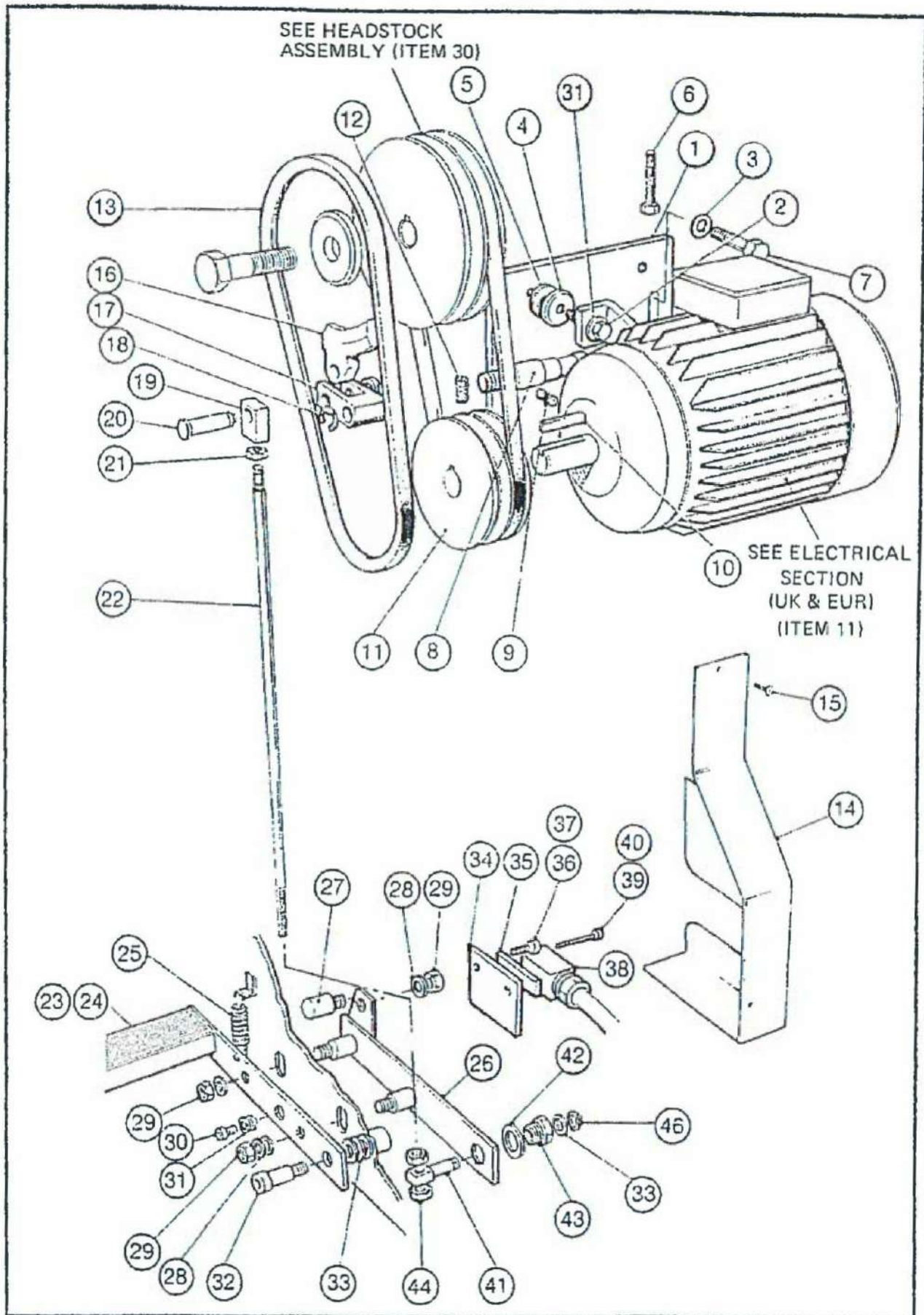

BRAKE AND DRIVE ASSEMBLY - Contd

ITEM	PART No	DESCRIPTION	QTY
27	S2501C035	STUD	1
28	FP-0136	WASHER, M12	3
29	FS-0924	NUT, M12	3
30	FS-0158	SCREW, M8 X 12 CAP HD	2
31	FP-0050	WASHER, M8	8
32	FS-0010	SCREW, SHOULDER, M10 X 12 X 16	2
33	FP-0070	WASHER, M12 BRIGHT STEEL	7
34	S2501C033	PLATE, SWITCH MOUNTING	1
35	S2501C034	PLATE, CLAMPING	1
36	FS-0112	SCREW, M5 X 12 CAP HD SOCKET	2
37	FP-0030	WASHER, M5	2
38	E031-0013	SWITCH, LIMIT	1
39	FS-0102	SCREW, M4 X 30 CAP HD	2
40	FP-0170	WASHER, M4	2
41	S2501C022	STUD, CONNECTING	1
42	FP-0100	WASHER, M20	1
43	S2501C021	BUSH, BEARING	1
44	FS-0922	NUT, 10 mm	2
45	FS-0516	SCREW, M8 X 12 CUP POINT	1
46	RA-0090	CIRCLIP, 12 mm EXT	1

THIRD SHAFT SWITCH ASSEMBLY

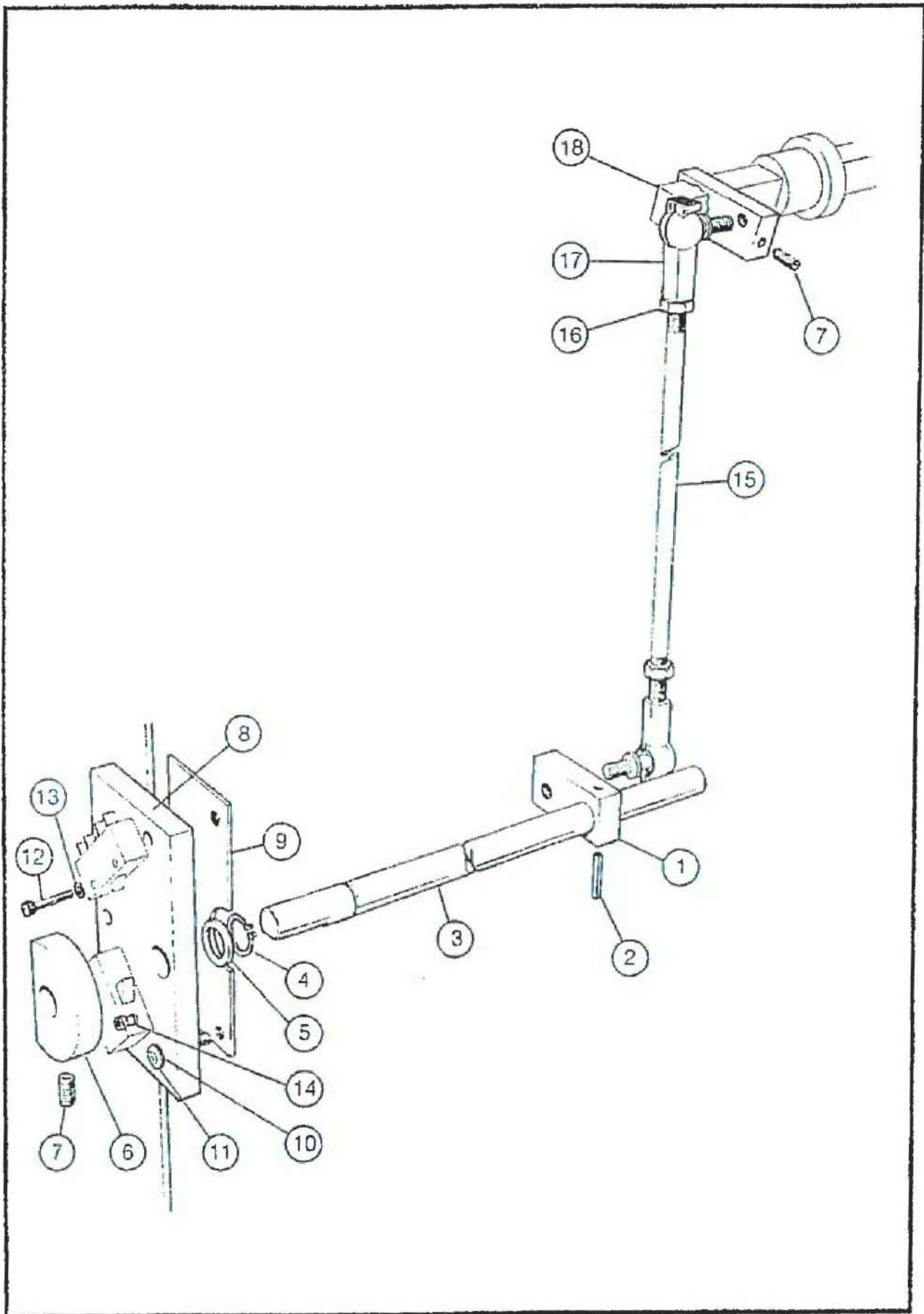

THIRD SHAFT ASSEMBLY

ITEM	PART No.	DESCRIPTION	QTY
1	D800H2007	LEVER, CAMSHAFT	1
2	FT-0170	PIN, SPIROL M4 X 22	1
3	D699-0968	CAMSHAFT	1
4	RA-0090	CIRCLIP	1
5	FP-0070	WASHER, M12	1
6	D011H3014	CAM	1
7	FS-0500	SCREW, M6 X 10 CUP POINT SKT	2
8	YQ-0020	BLOCK, MOUNTING	1
9	D565-2717	CLAMP PLATE	1
10	FP-0130	WASHER, LOC, M6	3
11	FS-0298	SCREW, M6 X 25 BUTTON WHD SKT	3
12	FS-0090	SCREW, M3, X 20 CAP HD	4
13	FP-0020	WASHER, M3	4
14	YR-0010	INSERT, THREAD, M3	4
15	D648-0145	CONNECTING ROD	1
16	FS-0918	NUT, M6	2
17	YN-0020	M10, BALL JOINT	2
18	D306H042.1	LEVER 3 RD SHAFT LINK	1

CHANGEWHEEL GUARDS

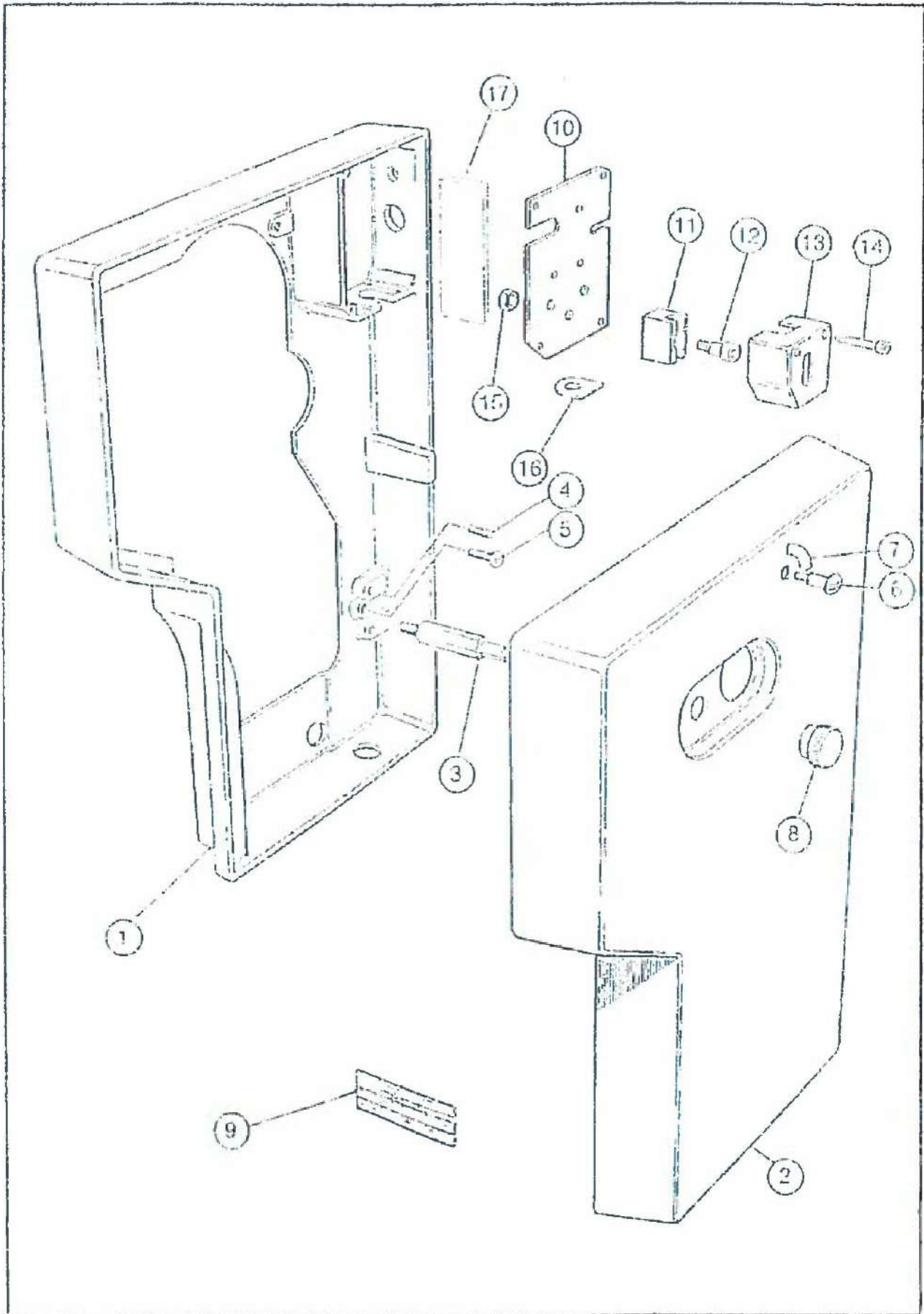

CHANGEWHEEL GUARDS

ITEM	PART No.	DESCRIPTION	QTY
1	S2501C027	GUARD, INNER	1
2	S2501C026	GUARD, OUTER	1
3	D502H1004	STUD	1
4	FS-0786	SCREW, M6 X 16 DOG POINT	2
5	FS-0788	SCREW, M6 X 20 BUTTIN HD DOG POINT	1
6	S2501C019	KEY-INTERLOCK	1
7	NA-1229/S	PLATE-GUARD INTERLOCK SWITCH	1
8	FS-0964	NUT, M10, DOMED	1
9	NC-0050	CHART, LUBRICATION	1
10	S2501C025	PLATE, MTG, INTERLOCK SWITCH	1
11	D901H015.4	BLOCK	1
12	FS-0011	SCREW, SHOULDER, M5 X 6 12	1
13	D901H016.1	CAM, INTERLOCK SWITCH	1
14	FS-0122	SCREW, M5 X 35 CAP HD	2
15	FS-0916	NUT, M5 BRASS LOCKING	2
16	D631H3001	PLATE	1
17	D537-1299	CHANGEWHEEL PLATE - METRIC	1
17	D537-1300	CHANGEWHEEL PLATE - IMPERIAL	1

HEADSTOCK

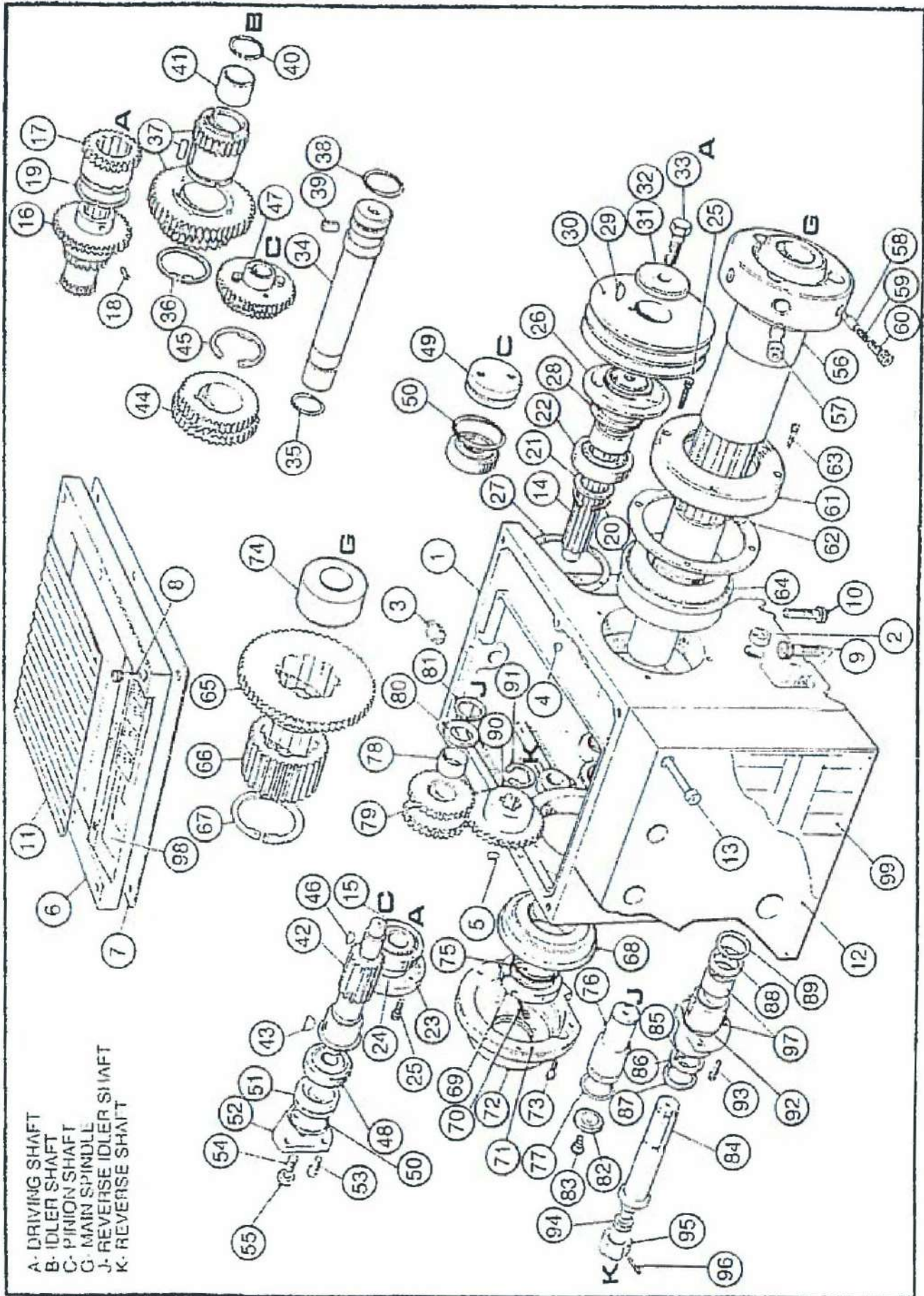

HEADSTOCK

ITEM	PART No.	DESCRIPTION	QTY
1	D384-0115J	HEADSTOCK, CASTING	1
2	WA-0010	WINDOW, OIL	1
3	PB-0030	PLUG, DRAIN, MAGNETIC ¾ in. BSP	1
4	D101H0002	TUBE, OIL FEED	1
5	D101H0002	TUBE, OIL FEED	1
6	S2502C002P	COVER, HEADSTOCK	1
7	GA-0470	GASKET, HEADSTOCK COVER	1
8	FS-0138	SCREW, M6 X 25 CAP HD SKT	6
9	FS-0210	SCREW, M12 X 35 CAP HD SKT	2
10	FS-0212	SCREW, M12 X 40 CAP HD SKT	1
11	GD-0020	MAT, RUBBER	1
12	S2502C001	PIECE, DISTANCE	1
13	FS-0179	SCREW, M8 X 65 CAP HD SKT	4
A	M302-SHAFT A	DRIVING SHAFT ASSEMBLY	1
14	D699-0986J	SHAFT, DRIVE	1
15	BG-0020	BEARING	1
16	A802H0102J	GEAR ASSY	1
17	D344-1453J	GEAR, 31 TEETH	1
18	FT-0290	PIN, TENSION, M6 X 10 (HEAVY DUTY)	1
19	RA-0400	CIRCLIP	1
20	RA-0150	CIRCLIP	1
21	D001H2069	WASHER, SPACING	1
22	BG-0030	BEARING	1
23	D000H5001	CAP, END	1
24	GA-0160	GASKET	1
25	FS-0114	SCREW, M5 X 16 CAP HD SKT	6
26	D011H5011	CAP, END	1
27	GA-0100	GASKET	1
28	OB-0020	SEAL, OIL	1
29	KA-0200	KEY, WOODRUFF	1
30	D031H6011	PULLEY	1
31	D702H111.1	WASHER, RETAINING	1

HEADSTOCK

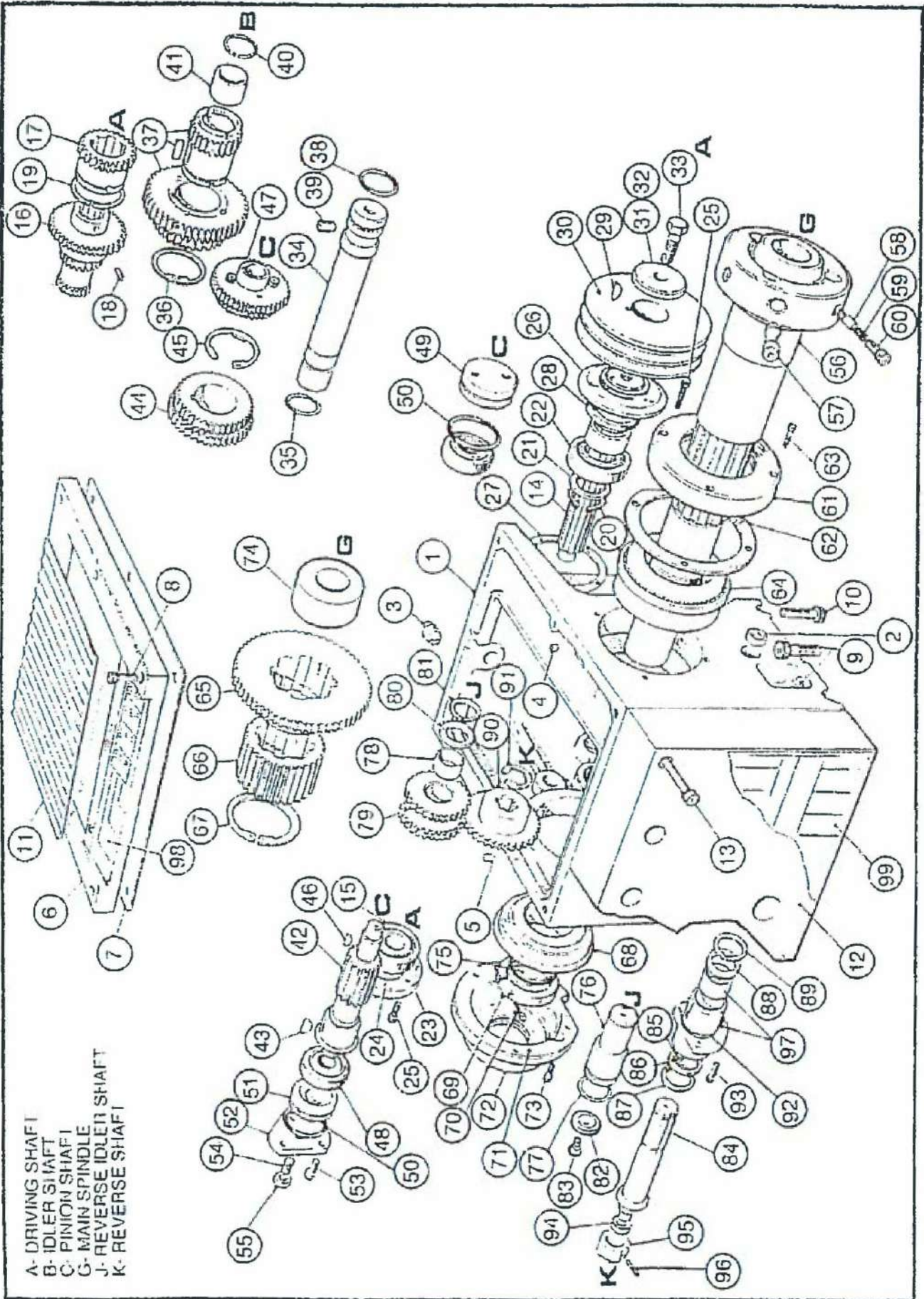

HEADSTOCK - contd

ITEM	PART No.	DESCRIPTION	QTY
32	FO-0060	WASHER, SAFETY	2
33	FS-0560	SCREW, M6 X 20 HEX HD (BLACK)	2
B	M302-SHAFT B	IDLER SHAFT ASSEMBLY	1
34	D232H2005	SHAFT, IDLER	1
35	OA-0110	'O' RING	1
36	RA-0170	CIRCLIP	1
37	A802H0105J	GEAR ASSEMBLY	1
38	OA-0120	'O' RING	1
39	FS-0156	SCREW, M8 X 12 CUP POINT	1
40	RA-0290	CIRCLIP	2
41	BF-0150	BEARING, GLACIER	2
C	M302-SHAFT C	PINION SHAFT ASSEMBLY	1
42	D262H3002	SHAFT, 2 nd	1
43	KA-0190	KEY, WOODRUFF	1
44	A802H0104	GEAR ASSEMBLY	1
45	RA-0350	CIRCLIP	1
46	KA-0180	KEY, WOODRUFF	1
47	A802H0103	GEAR ASSEMBLY	1
48	BG-0020	BEARING	2
49	D031H3006	BUSH, BEARING, LOCATING	1
50	OA-0220	'O' RING	2
51	D031H3005	BUSH, BEARING, LOCATING	1
52	D002H5003	CAP, END	1
53	FS-0114	SCREW, M5 X 16 CAP HD SKT	3
54	FS-0518	SCREW, M5 X 16 CUP POINT	1
55	FS-0920	NUT, M8, BRIGHT	1
G	M302-SHAFT G	MAIN SPINDLE ASSEMBLY	1
56	D709-0126J	MAIN SPINDLE	1
57	D131H1001	CAM	3
58	D101H0004	PLUNGER,DETENT	3
59	FR-0115	SPRING	3
60	FS-0160	SCREW, M8 X 16 CAP HD SKT	1
61	D013H7001	COVER, BEARING	1

HEADSTOCK

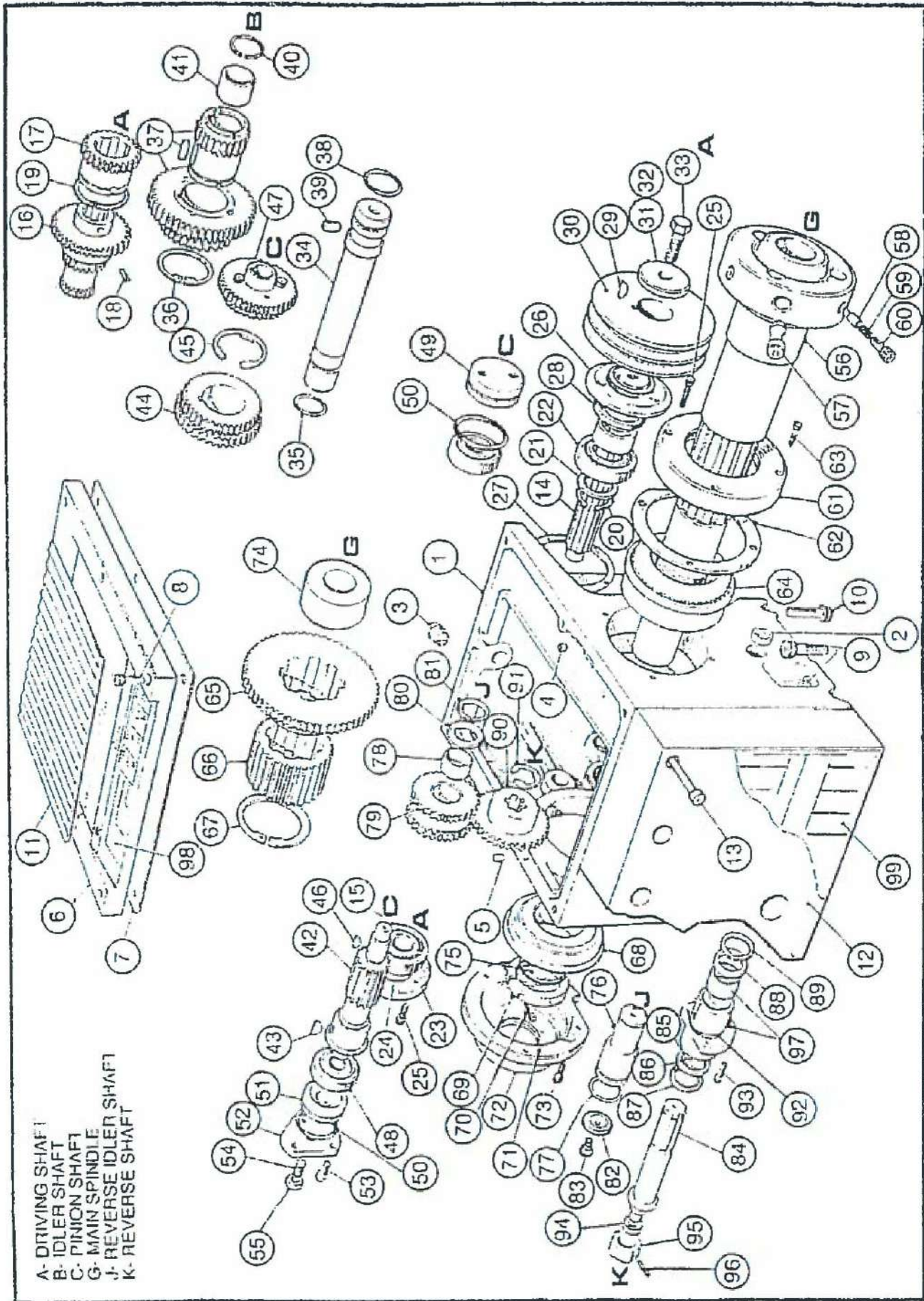

HEADSTOCK - contd

ITEM	PART No.	DESCRIPTION	QTY
62	GA-0110	GASKET, BEARING COVER	1
63	FS-0120	SCREW, M5 X 30 CAP HD SKT	4
64	BA-0040	BEARING	1
65	D344-1458J	GEAR, 81 TEETH	1
66	D344-1457J	GEAR, 41 TEETH	1
67	RA-0040	CIRCLIP	1
68	BA-0050	BEARING	1
69	D001H5004	LOCKNUT	1
70	FS-0118	SCREW, M5 X 25 CAP HD	1
71	GA-0120	GASKET	1
72	D302H101.1	COVER, REAR BEARING	1
73	FS-0114	SCREW, M5 X 16 CAP HD SKT	4
74	D302H103.1	SPACER	1
75	D302H104.1	SLEEVE, FINGER	1
J	M302-SHAFT J	REVERSE IDLER SHAFT ASSEMBLY	1
76	D302H023.1/V	SHAFT, REVERSE IDLER	1
77	OA-0150	'O' RING	1
78	BF-0130	BEARING, GLACIER	2
79	D341H5006	GEAR, 33 TEETH	1
80	D001H2078	SPACER	1
81	RA-0140	CIRCLIP	1
82	D402H020.1	WASHER	1
83	FS-0130	SCREW, M6 X 10 CAP HD SKT	1
K	M302-SHAFT K	REVERSE SHAFT ASSEMBLY	1
84	D260H2011	SHAFT, REVERSE, IMPERIAL	1
85	FT-0050	PIN, SPIROL, M3 X 10	1
86	D001H2078	SPACER	1
87	OB-0040	SEAL, OIL	1
88	D001H2071	SPACER	1
89	RA-0130	CIRCLIP	1
90	D311H6012	GEAR, REVERSE, 46 TEETH	1
91	RA-0340	CIRCLIP	1
92	OA-0160	'O' RING	1

HEADSTOCK

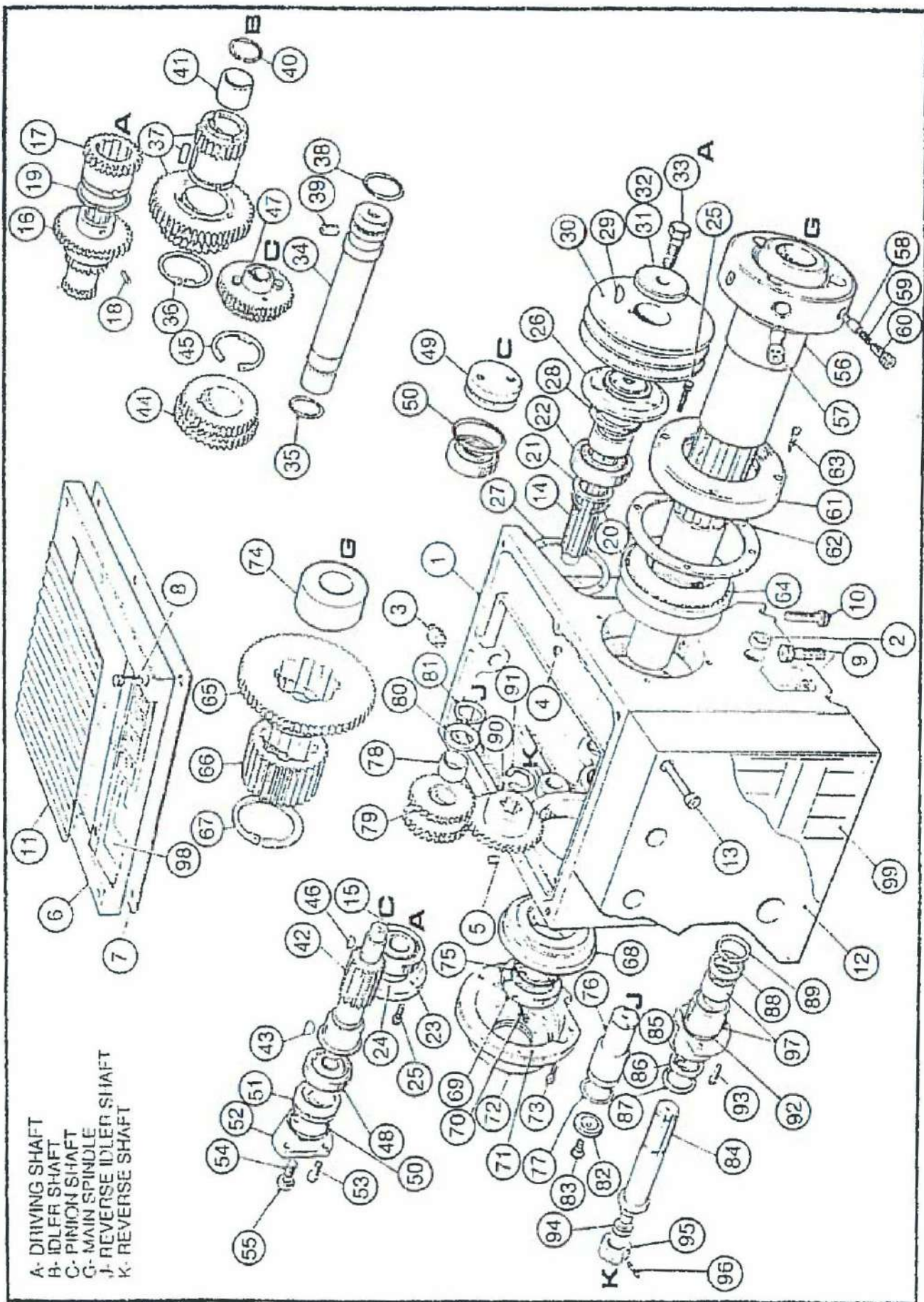

HEADSTOCK - contd

ITEM	PART No.	DESCRIPTION	QTY
93	FS-0114	SCREW, M5 X 16 CAP HD SKT	3
94	D001H2072	SPACER	1
95	D001H2098	SLEEVE, SPLINED - IMPERIAL	1
96	FT-0670	PIN, GROOVED, 5/32 in. X ¾ in.	1
97	A802H0804	SHAFT, BEARING ASSEMBLY	1
98	NA-1443	SPEED PLATE, 40-2500 RPM	1
99	D537-1289	THREAD & FEED PLATE	1
100	D557-0164	SET OVER PAD	1
101	D560-0389	SET OVER PIN	2
102	B111-5160	SPIROL PIN 10 DIA X 40	2
103	B164-0170	M12 X 20 SET SCREW	2
104	FS-0190	M10 X 40 CAP SCREW	1

HEADSTOCK SELECTORS

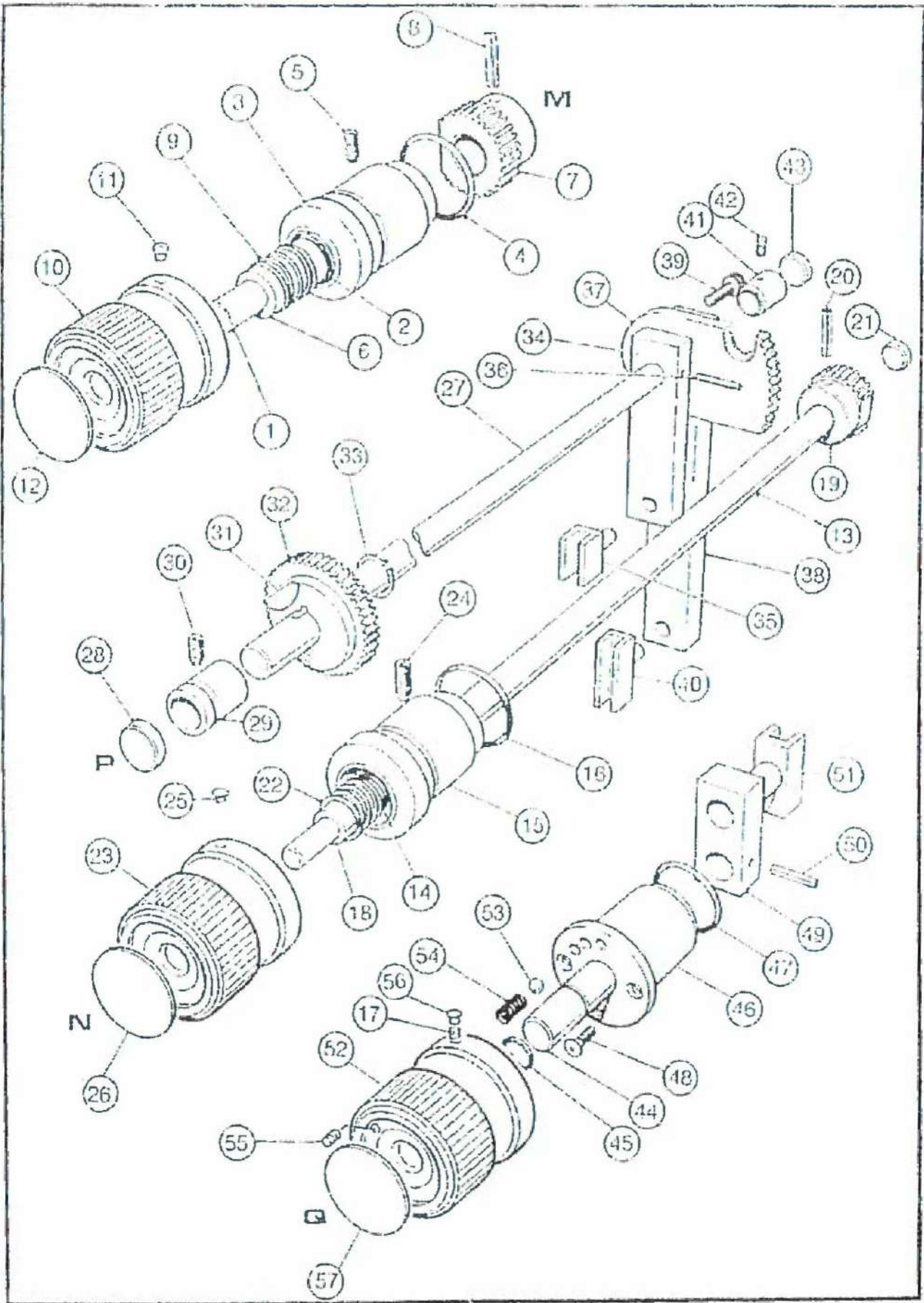

HEADSTOCK SELECTORS

ITEM	PART No	DESCRIPTION	QTY
	M302-SHAFT-M	SELECTOR SHAFT ASSEMBLY, LH	1
1	S2502C004	ROD, SELECTOR, LH	1
2	OB-0050	RING, SOFT	1
3	D131H3008	BUSH, LH	1
4	OA-0170	'O' RING	1
5	FS-0348	SCREW, M6 X 10 DOG POINT SKT	1
6	BD-0020	BEARING, NEEDLE ROLLER	1
7	D311H2018	GEAR, SELECTOR 20 TEETH	1
8	FT-0180	PIN SPIROL 4 X 24 MM	1
9	FR-0002	SPRING	1
10	S2502C008	KNOB SELECTOR	1
11	ED-0275	PLUG, WHITE	1
12	ED-1425	CAP END	1
	M302-SHAFT-N	SELECTOR SHAFT ASSEMBLY, RH	1
13	S2502C003	ROD, SELECTOR, RH	1
14	OB-0050	RING, SOFT	1
15	D131H3007	BUSH, RH	1
16	OA-0170	'O' RING	1
17	FS-0348	SCREW, M6 X 10 DOG POINT	3
18	BD-0020	BEARING, NEEDLE ROLLER	1
19	D311H2018	GEAR SELECTOR 20 TEETH	1
20	FT-0180	PIN, SPIROL 4 X 24 MM	1
21	D000H1002	PLUG	1
22	FR-0002	SPRING	1
23	S2502C008	KNOB, SPEED SELECTOR	1
24	FS-0356	SCREW, M6 X 16 DOG POINT	1
25	ED-0275	PLUG, WHITE	1
26	ED-1425	CAP, END	1
	M302-SHAFT-P	SELECTOR ROD ASSEMBLY	1
27	D230H1011	ROD SELECTOR	1
28	D000H2011	PLUG, HEADSTOCK	1

(Contd)

HEADSTOCK SELECTORS

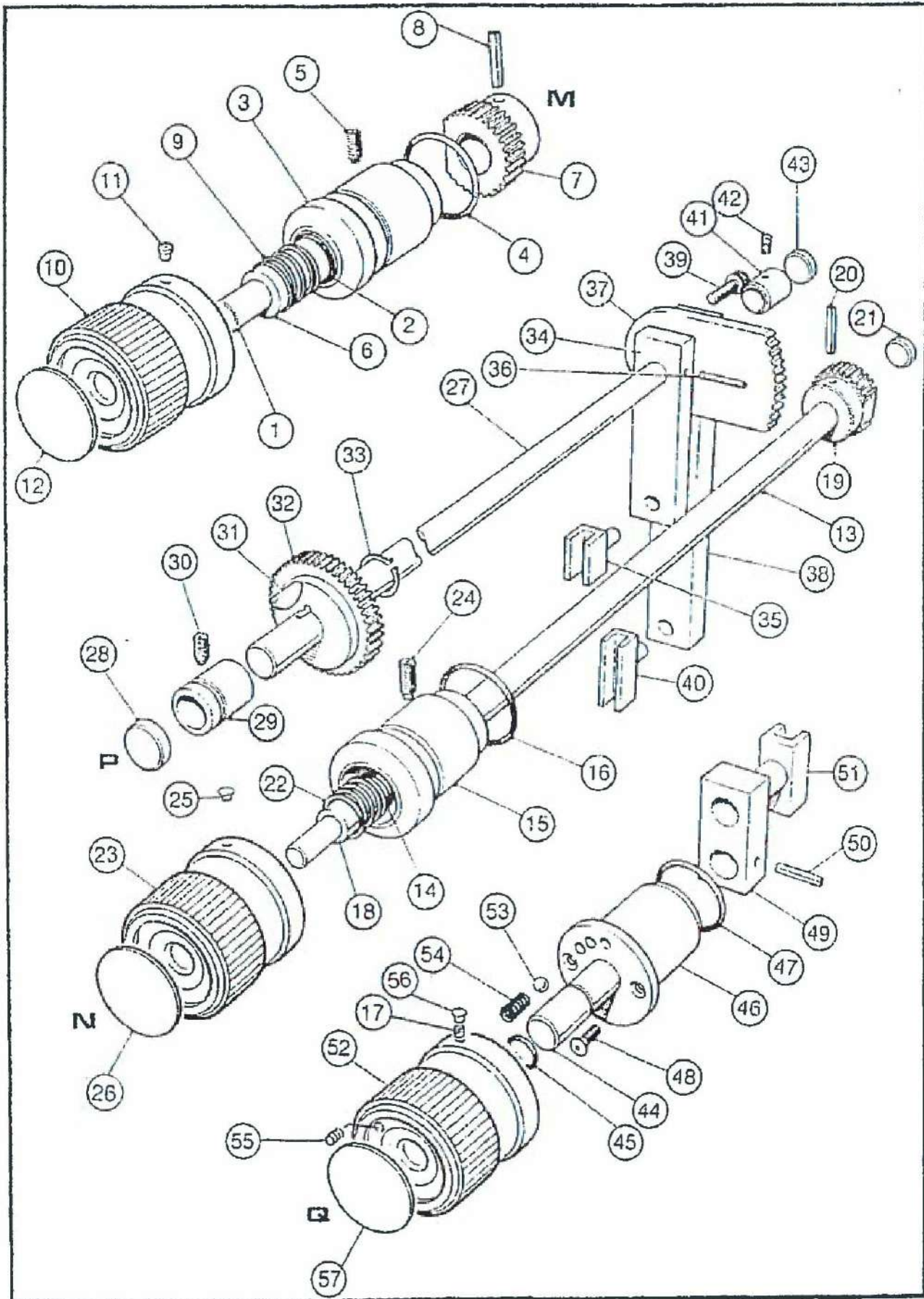

HEADSTOCK SELECTORS - Contd

ITEM	PART No	DESCRIPTION	QTY
29	BE-0150	BEARING, OILITE	1
30	FS-0346	SCREW, M6 X 8 HALF DOG POINT	1
31	KA-0170	KEY, WOODRUFF	1
32	D311H4016	GEAR, SELECTOR	1
33	RA-0100	CIRCLIP	1
34	D700H2007	LEVER, SHIFTER	1
35	D411H2017	SHOE, SELECTOR	1
36	FT-0180	PIN, SPIROL 4 X 24 MM	1
37	D436H6004	QUADRANT, GEAR	1
38	D704H2001	LEVER, SELECTOR	1
39	FS-0114	SCREW, M5 X 16 CAP HD SKT	1
40	D411H2020	SHOE, SELECTOR	1
41	D101H2112	BEARING	1
42	FS-0130	SCREW, M6 X 10 SKT	1
43	D000H2006	PLUG	1
	M302-SHAFT-Q	REVERSE LEVER ASSEMBLY	1
44	S250C005	ROD REVERSE SELECTOR	1
45	OA-0010	'O' RING	1
46	D131H3011	BUSH SELECTOR	1
47	OA-0090	'O' RING	1
48	FS-0426	SCREW, M4 X 10 COUNTERSUNK SKT	2
49	D800H1004	LEVER SELECTOR	1
50	FT-0150	PIN, SPIROL M4 X 20	1
51	D411H2018	SHOE, SELECTOR	1
52	S2502C009	KNOB, FEED SELECTOR	1
53	UB-0005	BALL, STEEL 5 MM	1
54	FR-0009	SPRING	1
55	FS-0500	SCREW, M6 X 10 CUP POINT	3
56	ED-0275	PLUG, WHITE	1
57	ED-1425	CAP, END	1

GEARBOX ASSEMBLY

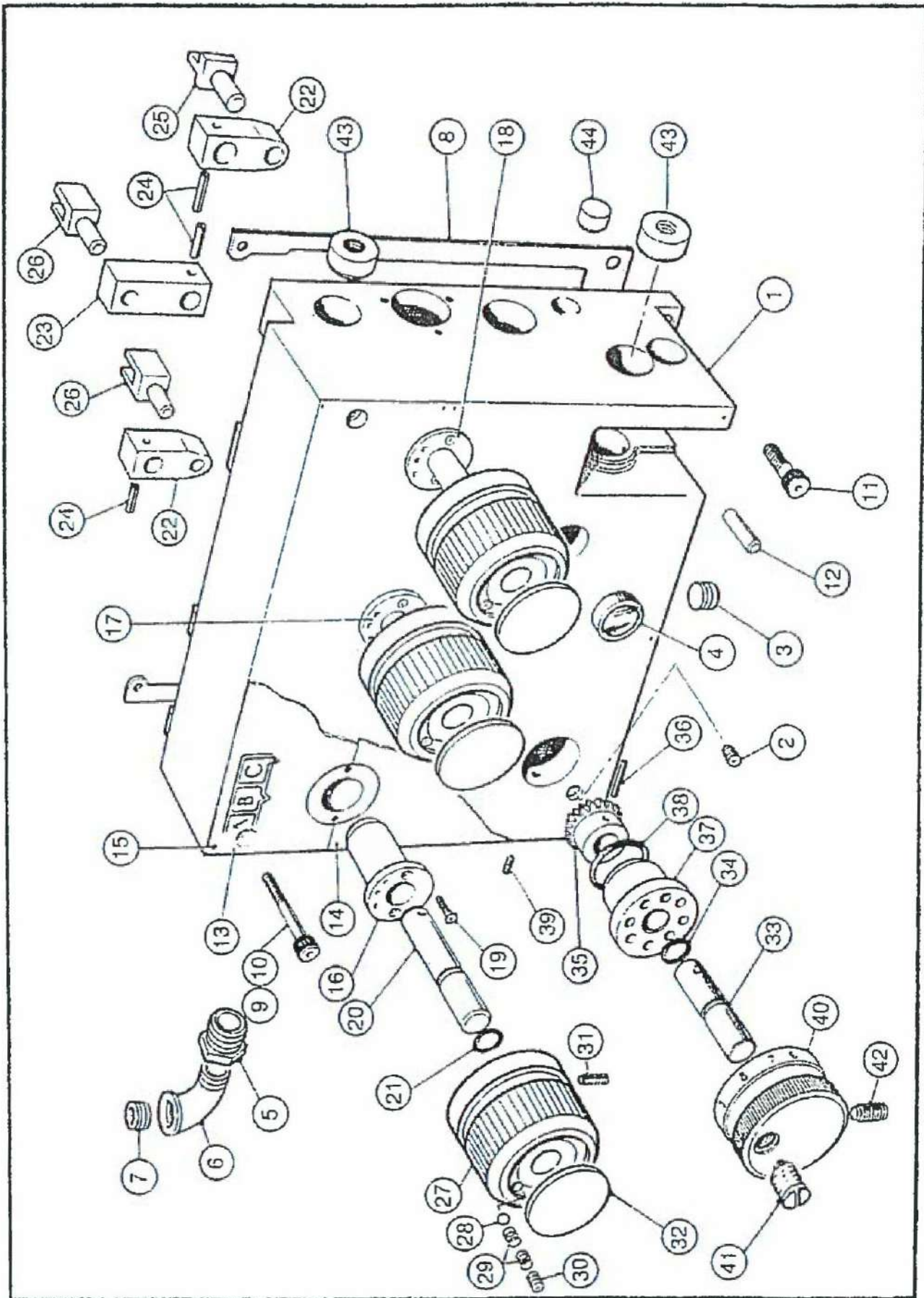

GEARBOX ASSEMBLY

ITEM	PART No.	DESCRIPTION	QTY
1	D303H503.1P	GEARBOX	1
2	PB-0085	PLUG ¼ in. BSP SKT PRESSURE	1
3	PB-0090	PLUG 3/8 in. BSP SKT PRESSURE	1
4	WA-0010	WINDOW, OIL	1
5	D303H002.1/V	CONNECTOR, REDUCING	1
6	PB-0055	ELBOW ½ in. BSPT 90° M/F	1
7	PB-0110	PLUG ½ in. BSPT SKT	1
8	GA-0150	GASKET	1
9	FS-0180	SCREW, M8 X 70 CAP HD	1
10	FS-0178	SCREW, M8 X 60 CAP HD	1
11	FS-0164	SCREW, M8 X 25 CAP HD	3
12	FT-0580	PIN,GROOVED, M8 X 25	2
13	NA-1314	PLATE, TOP BOTTOM	1
14	NA-1315	PLATE, BOTTOM	1
15	B123-6024	SCREW, No. 4 ¼ in. PAN HD SELF TAP	10
	M303-LEVERS	SELECTOR LEVER ASSEMBLY	
16	D111H2017	BUSH, SELECTOR LH	1
17	D111H2018	BUSH, SELECTOR CENTRE	1
18	D111H2016	BUSH, SELECTOR RH	1
19	FS-0426	SCREW, M4 X 10 CSK SKT HD	6
20	D230H0003	SHAFT SELECTOR	3
21	OA-0010	'O' RING	3
22	D800H1002	LEVER, SELECTOR	2
23	D800H1001	LEVER, SELECTOR	1
24	FT-0150	SCREW, M4 X 20 SPIROL	3
25	D411H1003	SHIFTER, GEAR	1
26	D411H1004	SHIFTER, GEAR	2
27	S2502C009	KNOB, FEED REVERSE	3
28	UB-0005	BALL, STEEL 5MM	3
29	FR-0009	SPRING (2 SPRINGS EACH HOLE)	6
30	FS-0502	SCREW, M6 X 12 CUP POINT	3
31	FS-0356	SCREW, M6 X 16 DOG POINT	3
32	ED-1425	CAP, END	3

(Contd)

GEARBOX ASSEMBLY

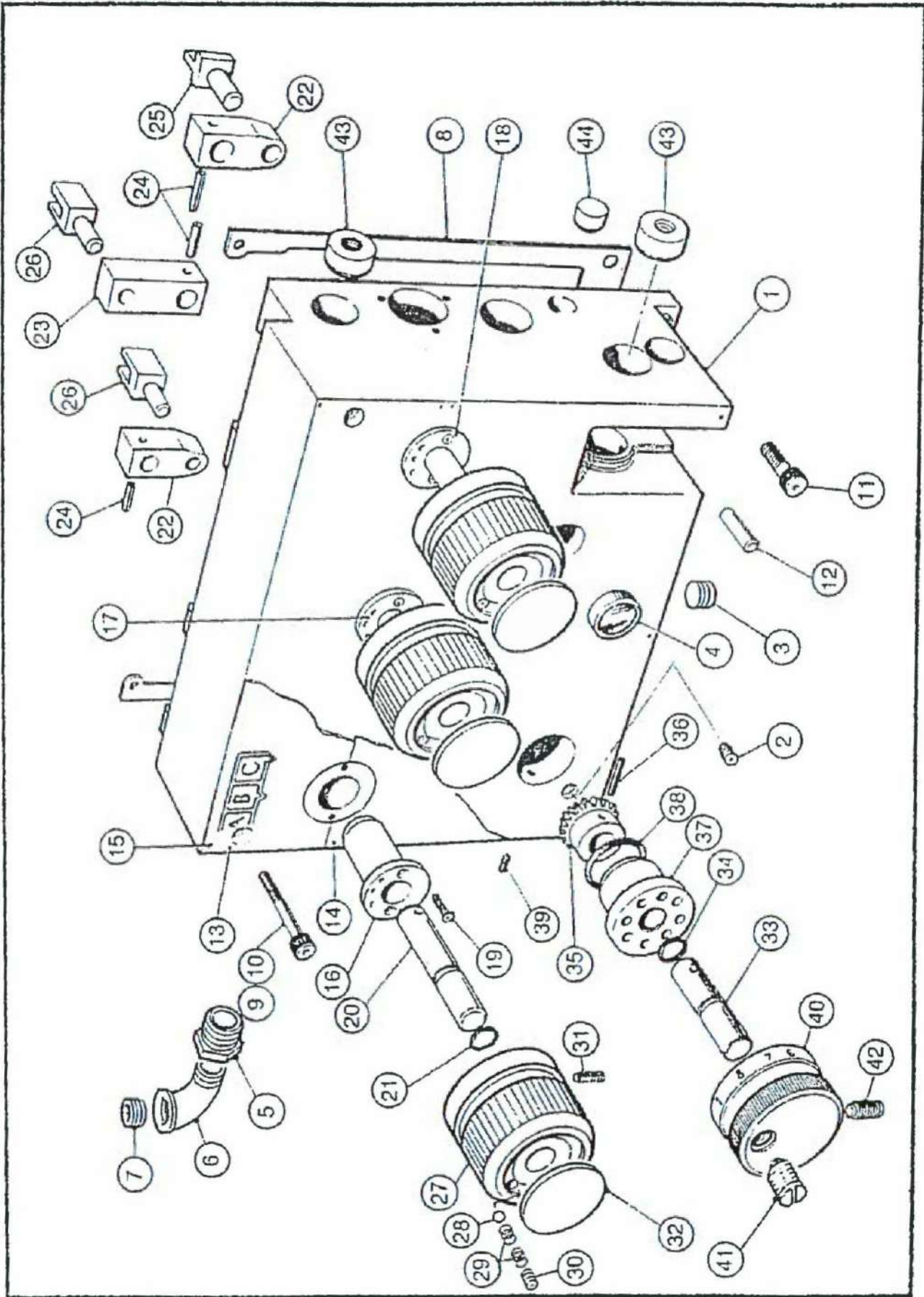

GEARBOX ASSEMBLY - Contd

ITEM	PART No	DESCRIPTION	QTY
	M303-DIAL	SELECTOR DIAL ASSEMBLY	1
33	D230H1012	SHAFT	1
34	OA-0030	'O' RING	1
35	D371H2001	GEAR, BEVEL	1
36	FT-0180	PIN, SPIROL M4 X 24	1
37	D131H3010	BUSH	1
38	OA-0160	'O' RING	1
39	FS-0348	SCREW, M6 X 10 DOG POINT	1
40	D111H3017	DIAL, SELECTOR	1
41	FS-0048	DETENT, BALL SCREW, M10	1
42	FS-0352	SCREW, M6 X 12 DOG POINT	1
43	D102H2005	PLUG - CASTING TOP	2
44	D100H2001	PLUG - CASTING BOTTOM	1

GEARBOX GEARS AND SHAFTS

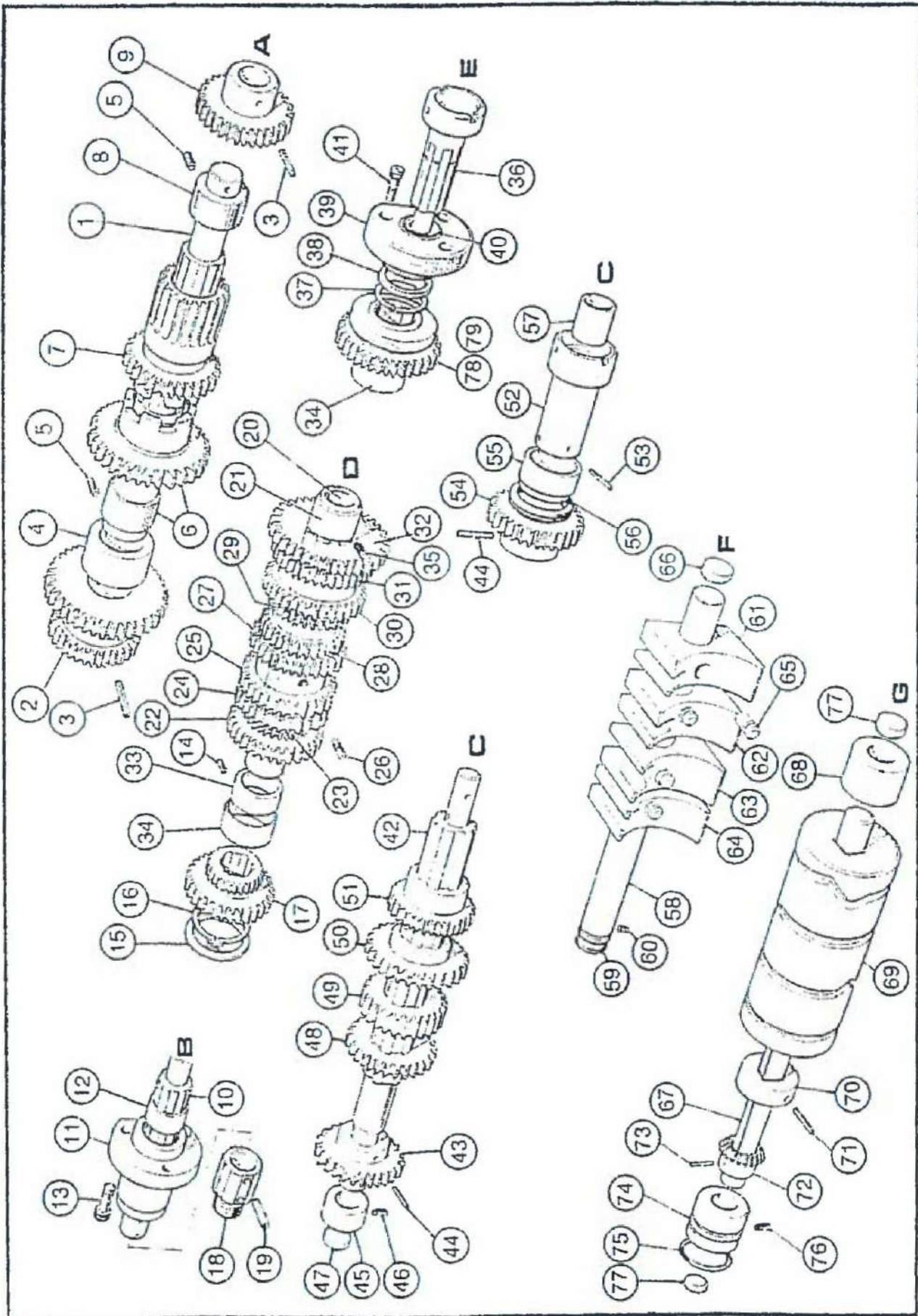

GEARBOX GEARS AND SHAFTS

ITEM	PART No	DESCRIPTION	QTY
	MV03-SHAFT-A	TOP SHAFT ASSEMBLY	1
1	D210H1025	SHAFT, TOP	1
2	D341H5007	GEAR, 19/50 TEETH	1
3	FT-0270	PIN SPIROL, M5 X 32	2
4	D101H2099	BUSH	1
5	FS-0348	SCREW, M6 X 10 DOG POINT	2
6	A803H0102	GEAR ASSEMBLY	1
7	D334H3001	GEAR, 33/19 TEETH	1
8	BE-0230	BUSH, 14 X 25 X 16 PHOSPHOR BRONZE	1
9	D311H3033	GEAR 35 TEETH	1
	M303-SHAFT-B	INPUT SHAFT ASSEMBLY	1
10	D260H2010	SHAFT, INPUT	1
11	D141H4004	HOUSING	1
12	BF-0120	BEARING, GLACIER	2
13	FS-0118	SCREW, M5 X 25 CAP HD	3
14	FS-0508	SCREW, M6 X 25 W POINT SKT	1
15	D001H2080	SPACER	1
16	RA-0110	CIRCLIP	1
17	D361H3001	GEAR, 20/19 TEETH	1
18	D121H2008	SLEEVE, CHANGEWHEEL	1
19	FT-0170	PIN, SPIROL, M4 X 22	2
	M303-SHAFT-D	MIDDLE SHAFT ASSEMBLY	1
20	A803H0103	SHAFT, PINION SLEEVE ASSEMBLY	1
21	BF-0060	BEARING, GLACIER	1
22	D301H3022	GEAR, 22 TEETH	1
23	D301H2012	GEAR, 19 TEETH	1
24	D311H3032	GEAR, 20 TEETH	1
25	D311H4019	GEAR, 24 TEETH	1
26	FS-0348	SCREW, M6 X 10 DOG POINT SKT	1
27	D311H4018	GEAR, 23 TEETH	1
28	D311H3031	GEAR, 27 TEETH	1
29	D311H3030	GEAR, 24 TEETH	1
30	D311H4017	GEAR, 28 TEETH	1

(Contd)

GEARBOX GEARS AND SHAFTS

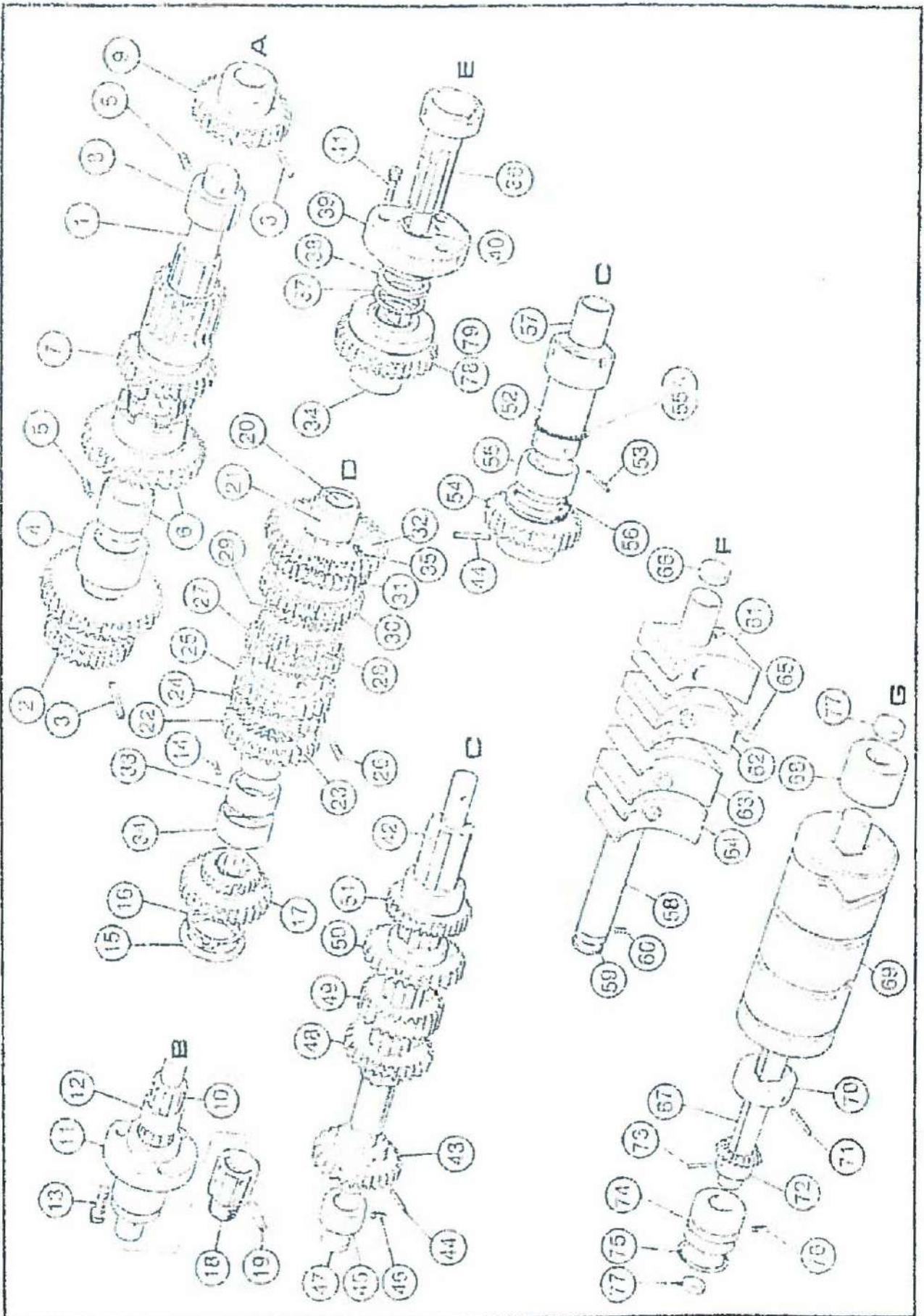

GEARBOX GEARS AND SHAFTS - Contd

ITEM	PART No.	DESCRIPTION	QTY
31	D301H4028	GEAR,26 TEETH	1
32	D311H5014	GEAR,38 TEETH	1
33	D101H2107	BEARING	1
34	D101H2101	BEARING	2
35	FS-0346	SCREW, M6 X 8 HALF DOG POINT SKT	2
	M303-SHAFT-E	OUTPUT SHAFT ASSEMBLY	1
36	D131H3009	SHAFT,OUTPUT	1
37	RA-0130	CIRCLIP	1
38	D001H2081	SPACER	1
39	D303H502.1	CAP,BEARING	1
40	BF-0130	BEARING, GLACIER	1
41	FS-0094	SCREW, M4 X 12 CAP HD	3
	M303-SHAFT-C	BOTTOM SHAFT ASSEMBLY	1
42	D240H1012	SHAFT, BOTTOM	1
43	D311H4020	GEAR, 22 TEETH	1
44	FT-0270	PIN,SPIROL M5 X 32	2
45	BE-0220	BUSH 14 X 25 X 22 PHOSPHOR BRONZE	1
46	FS-0348	SCREW, M6 X 10 DOG POINT	1
47	D000H1002	PLUG	1
48	D311H3034	GEAR, 22 TEETH	1
49	D311H3036	GEAR, 22 TEETH	1
50	D341H4006	GEAR, 33 TEETH	1
51	D311H3035	GEAR, 22 TEETH	1
52	D699-0967	SHAFT DRIVE	1
53	FT-0140	PIN, SPIROL M4 X 18	1
54	D311H3037	GEAR, 36 TEETH	1
55	D046-0089	BUSH	1
55A	OB-0075	SEAL, OIL	1
56	OB-0030	SEAL, OIL	1
57	BF-0080	BEARING, GLACIER	1
	M303-SHAFT-F	SELECTOR SHAFT ASSEMBLY	1
58	D230H1020	SHAFT SELECTOR	1
59	OA-0030	'O' RING	1
60	FS-0348	SCREW, M6 X 10 DOG POINT SKT	1

(Contd)

GEARBOX GEARS AND SHAFTS

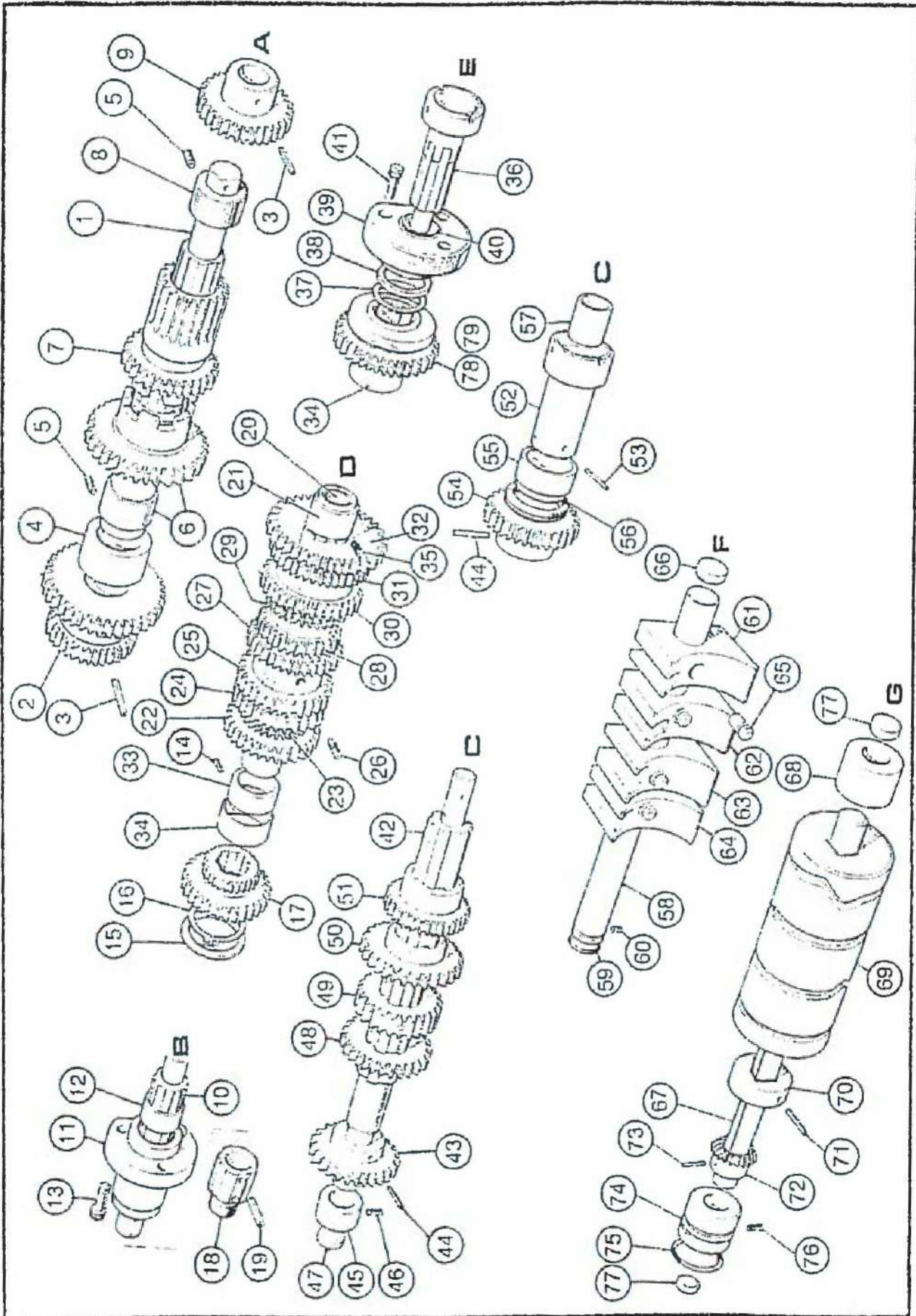

GEARBOX SHAFTS AND GEARS - Contd

ITEM	PART No	DESCRIPTION	QTY
61	D801H3005	BLOCK, CAM FOLLOWER 1	1
62	D801H3006	BLOCK, CAM FOLLOWER 2	1
63	D801H3007	BLOCK, CAM FOLLOWER 3	1
64	D801H3008	BLOCK, CAM FOLLOWER 4	1
65	D130H0003	PIN	4
66	D100H2001	PLUG	1
	M303-SHAFT-G	CAMSHAFT ASSEMBLY	1
67	D240H1013	CAM SHAFT	1
68	BE-0220	BUSH 14 X 25 X 22 PHOSPHOR BRONZE	1
69	CE-0050	CAM, FEED SELECTOR (SET OF 8 CAMS)	1
70	D001H2083	COLLAR, DRIVE	1
71	FT-0190	PIN, SPIROL M4 X 30	1
72	D371H2001	GEAR, BEVEL	1
73	FT-0180	PIN, SPIROL M4 X 24	1
74	D131H2008	BUSH	1
75	OA-0160	'O' RING	1
76	FS-0348	SCREW, M6 X 10 DOG POINT	2
77	D000H1002	PLUG	2
78	D331H3003	GEAR METRIC GEARBOX OR	1
79	D331H3004	GEAR ENGLISH GEARBOX	1

APRON

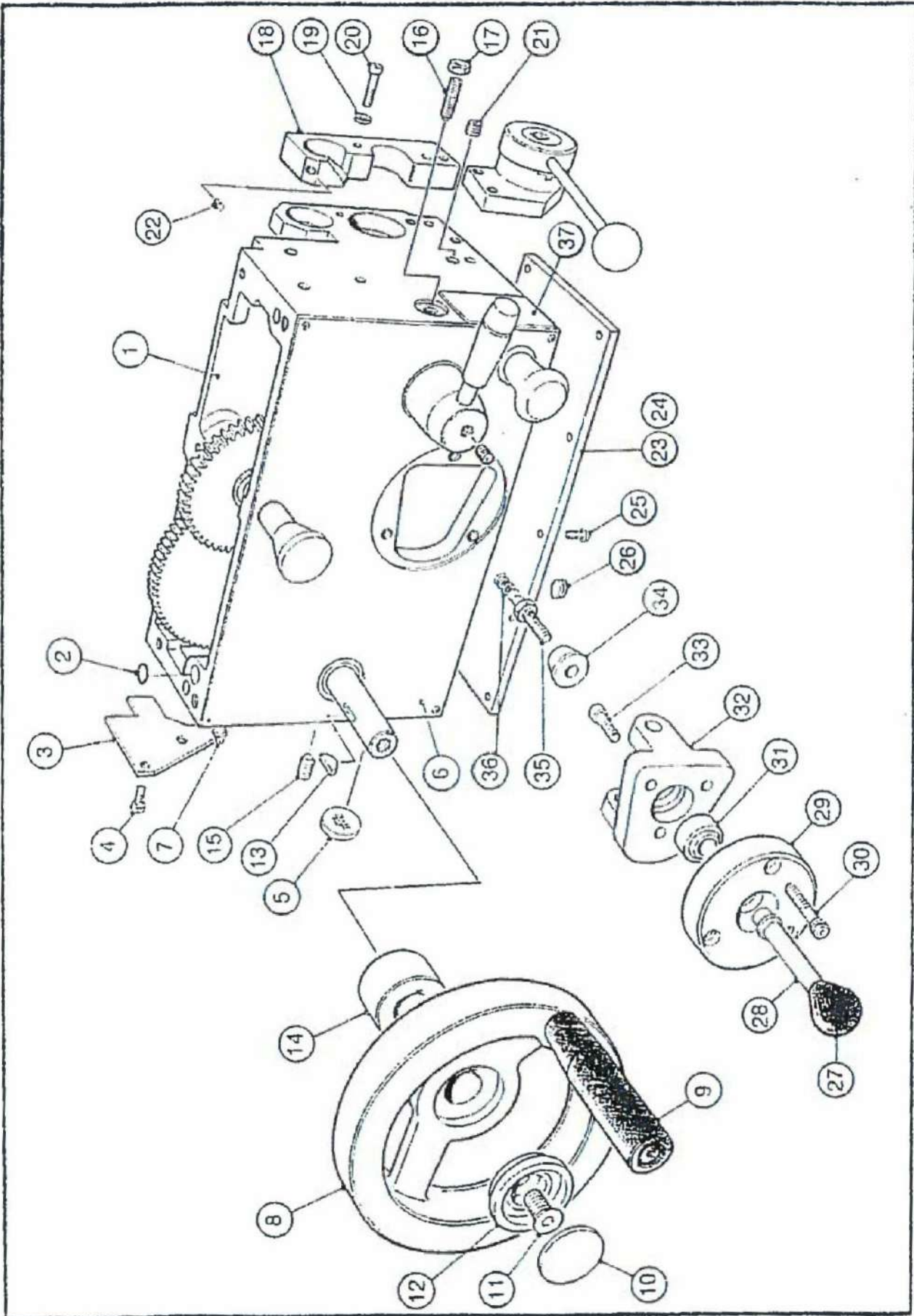

APRON

ITEM	PART No.	DESCRIPTION	QTY
1	D304H007.2	APRON	1
2	OA-0050	'O' RING (APRON TO SADDLE)	1
3	D304H024.2	PLATE, BAFFLE	1
4	FS-0704	M5 X 10 S/STEEL PAN HEAD SCREW	3
5	WA-0010	OIL WINDOW, 7/8"	1
6	NA-1446	NAME PLATE	1
7	B123-0624	No.4 X 1/4" SELF TAPPING, PAN HEAD SCREW	4
8	S2504C007	HANDWHEEL	1
9	HB-0030	HANDLE	1
10	ED-1425	CAP, BLACK	1
11	FS- 0784	M8 X 20 C/SUNK LOCKING SCREW	1
12	S2504C008	SPACER	1
13	KA-0180	KEY 5 X 7.5 X 19	1
14	S2504C006	SPACER	1
15	FS-0368	M8 X 16 DOG POINT SCREW	2
16	FS-0920	M8 X 35 DOG POINT SCREW	1
17	FS-0920	HEX NUT	1
18	D304H037.1	LEADSCREW SUPPORT BRACKET	1
19	FP-0040	WASHER, M6 BRIGHT	2
20	FS-0142	M6 X 35 CAP HEAD SCREW	2
21	PB-0170	PLUG, 1/8" BSPT	1
22	FS-0488	M4 X 5 CUP POINT SCREW	1
23	D304H011	BOTTOM COVER	1
24	GA-0680	GASKET	1
25	FS-0286	M5 X 12 BUTTON HEAD SCREW	12
26	PB-0085	PLUG, 1/4" BSP	1
27	HA-0050	KNOB	1
28	D704H018.1	LEVER, WORM BOX	1

(Contd)

APRON

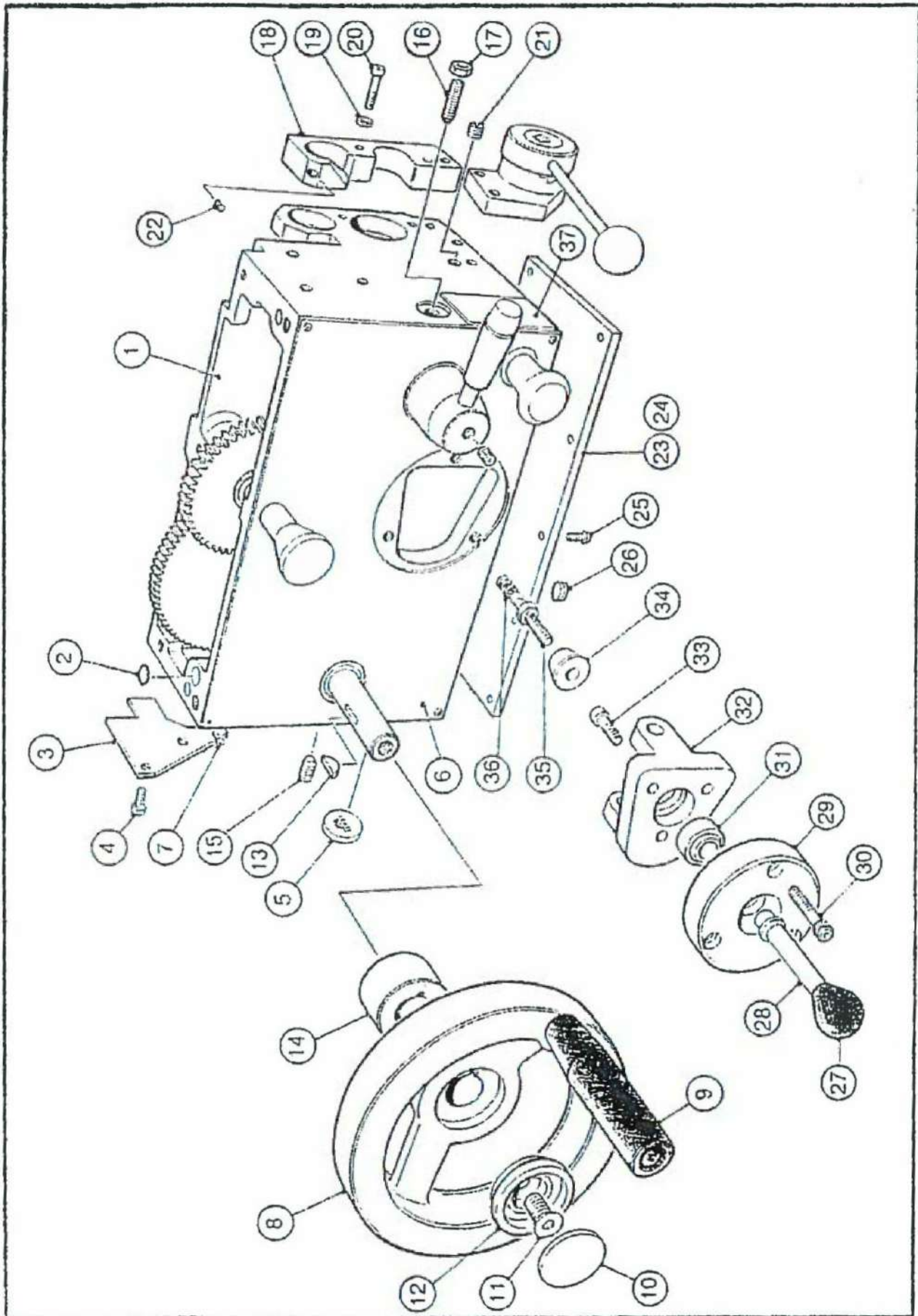

APRON - Contd

ITEM	PART No	DESCRIPTION	QTY
29	D304H027.1	COVER	1
30	FS-0138	SCREW, M6 X 25 CAP HD	3
31	YN-0015	BALL JOINT, RADIAL	1
32	D304H038.1	HOUSING, BALL JOINT	1
33	FS-0134	SCREW, M6 X 16 CAP HD	3
34	D304H036.1	SPACER, BALL STUD	1
35	YN-0005	BALL, STUD	1
36	FR-0185	SPRING	1
37	NA-0944	NAMEPLATE	1

APRON SHAFTS

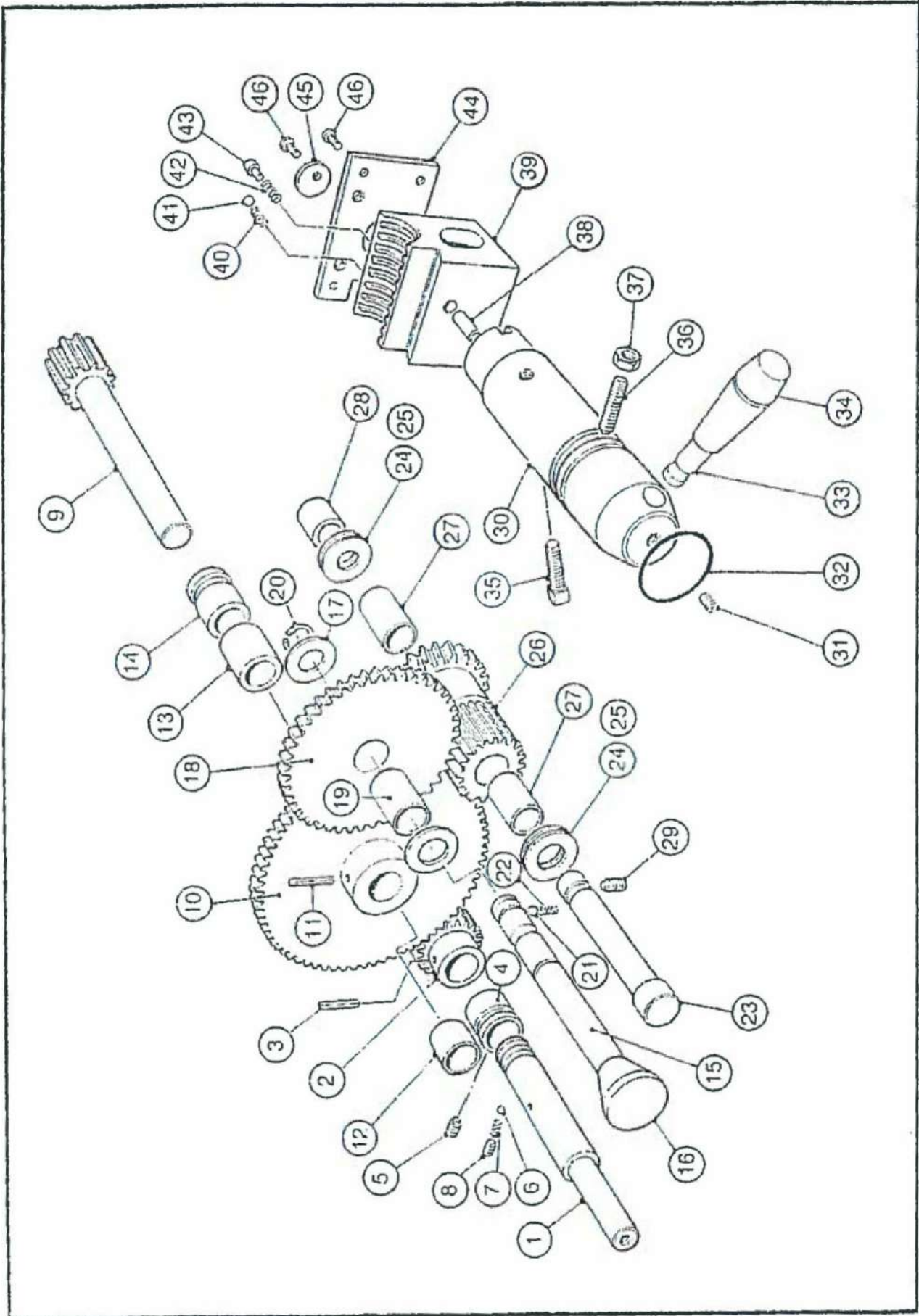

APRON SHAFTS

ITEM	PART No	DESCRIPTION	QTY
1	D232H1007	SHAFT, HANDWHEEL	1
2	D311H3038	PINION	1
3	FT-0260	PIN, SPIROL, M5 X 30	1
4	D031H2001	BUSH, PINION SHAFT	1
5	FS-0368	SCREW, M8 X 16 DOG POINT	1
6	UB-0006	BALL, STEEL, M6	1
7	FR-0125	SPRING	1
8	FS-0512	SCREW, M8 X 6 CUP POINT	1
9	D304H019.1	PINION, RACK	1
10	D341H6002	GEAR, RACK PINION	1
11	FT-0280	PIN, SPIROL, M5 X 36	1
12	BF-0120	BEARING, DU	1
13	BE-0130	BEARING, OILITE	1
14	D304H034.1	BEARING, PLAIN	1
15	D232H1005	SHAFT	1
16	D120H2023	KNOB	1
17	D001H2070	SPACER	1
18	D311H6013	GEAR, SLIDING	1
19	BF-0100	BEARING, DU	1
20	RA-0110	CIRCLIP, EXTERNAL	1
21	UB-0006	BALL, STEEL, M6	2
22	FR-0008	SPRING	1
23	D304H018.1	SHAFT, STUD	1
24	BC-0080	RACE, THRUST	2
25	BC-0090	WASHER, THRUST	4
26	D304H017.1	GEAR	1
27	BF-0100	BEARING, DU	2
28	D304H026.1	BUSH	1
29	FS-0356	SCREW, M6 X 16 DOG POINT	1
30	D304H020.1	SHAFT, LH	1
30	D304H041.1	SHAFT, RH	1
31	FS-0498	SCREW, M6 X 8 CUP POINT	1
32	OA-0190	'O' RING	1

(Contd)

APRON SHAFTS

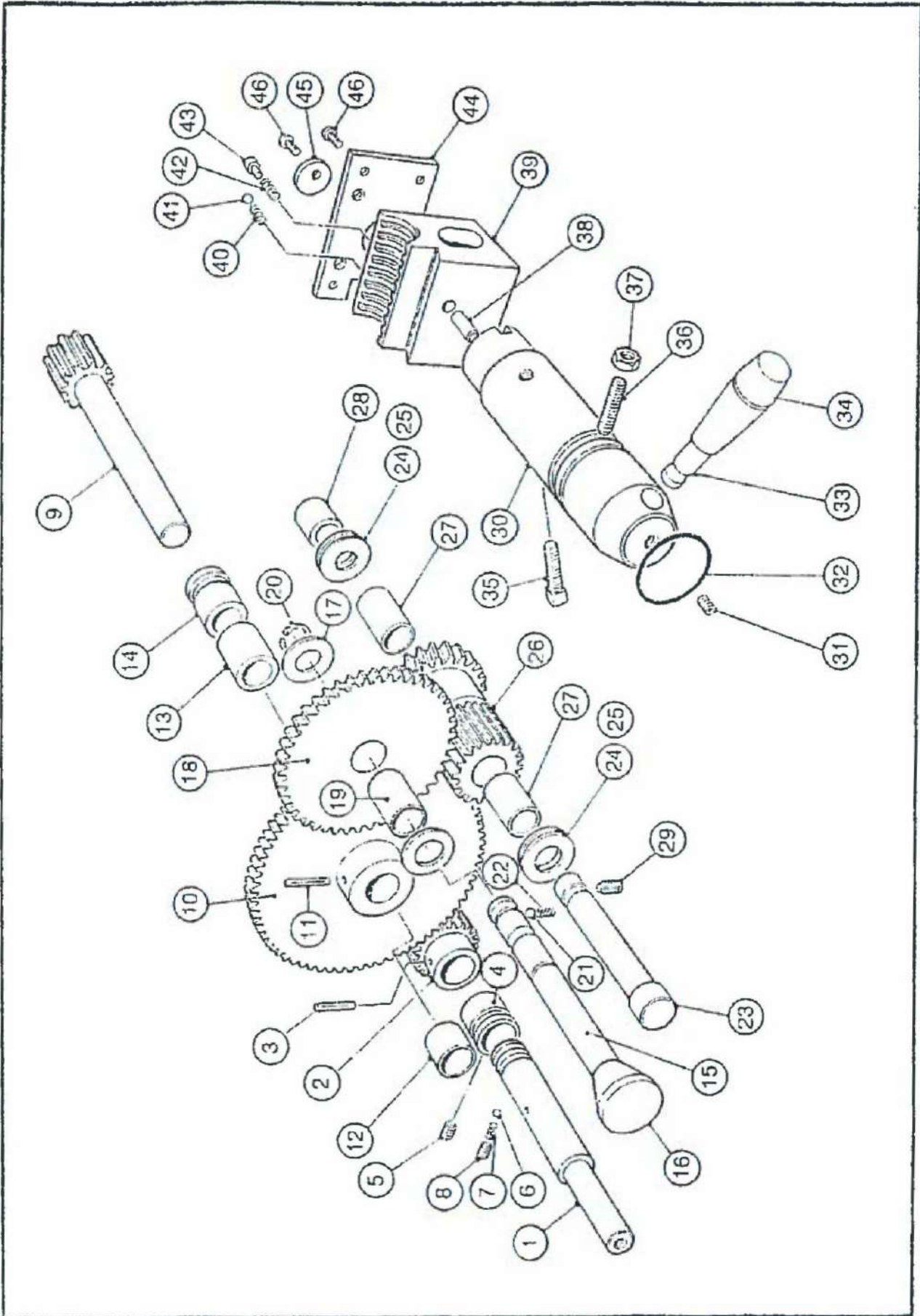

APRON SHAFTS - Contd

ITEM	PART No	DESCRIPTION	QTY
33	D304H046.1	STEM, OPERATING SHAFT	1
34	HA-0180	HANDLE	1
35	FS-0672	SCREW, M8 X 40 SQ HD, FLAT HT	1
36	FS-0369	SCREW, M8 X 35 DOG POINT	1
37	FS-0920	NUT, M8 LOCKING	1
38	FT-0547	PIN, DOWEL	1
39	D304H009.1	NUT, HALF (METRIC) OR	1
39	D304H010.1	NUT, HALF (IMPERIAL)	1
40	FR-0060	SPRING	2
41	UB-0008	BALL, STEEL, M8	2
42	FR-0080	SPRING	1
43	D304H033.1	PAD, BEARING	1
44	D304H021.1	PLATE, BRIDGE, LH OR	1
44	D304H045.1	PLATE, BRIDGE, RH	1
45	D304H022.1	WASHER, STOP	1
46	FS-0294	SCREW, M6 X 12 BUTTON HD	3

APRON WORM GEARING

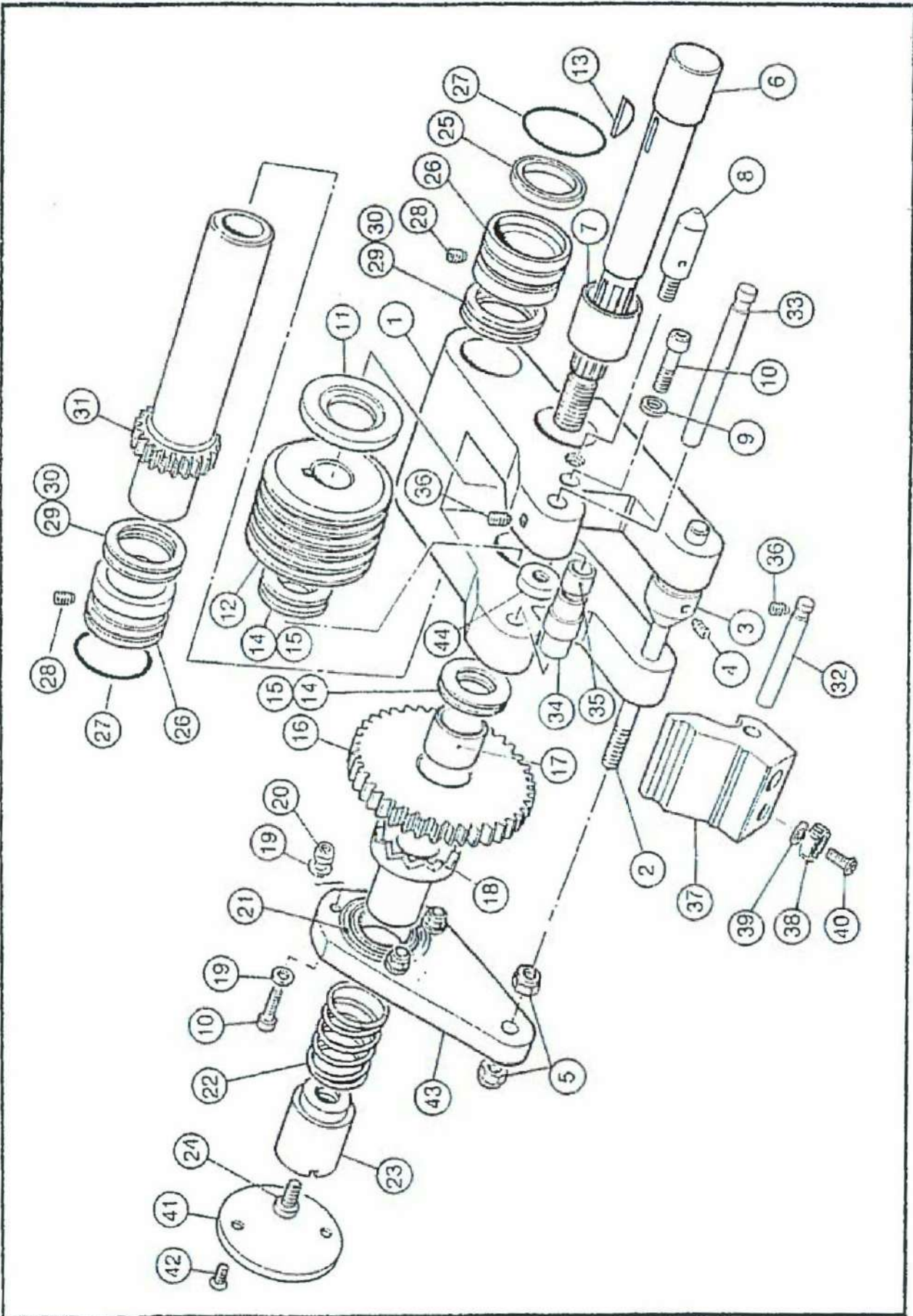

APRON WORM GEARING

ITEM	PART No	DESCRIPTION	QTY
1	D304H008.1	WORM BOX, LH OR	1
1	D304H042.1	WORM BOX, RH	1
2	D704H016.1	STUD	1
3	D304H032.1	COLLAR	1
4	FS-0530	SCREW, M5 X 5 CUP POINT	1
5	FS-0944	LOCKNUT, M6	2
6	D704H012.1	SHAFT, WORM BOX	1
7	BF-0130	BUSH	1
8	D304H023.1	STUD, INTERLOCK	1
9	FP-0030	WASHER, M5	1
10	FS-0116	SCREW, M5 X 20 CAP HD	4
11	D704H044.1	SPACER	1
12	D304H014.1	GEAR, HELICAL	1
13	KA-0180	KEY, WOODRUFF	1
14	BC-0080	RACE, THRUST	2
15	BC-0090	WASHER, THRUST	4
16	D704H010.1	GEAR, CLUTCH, 39T	1
17	BF-0095	LONG BUSH, 15 mm X 17 mm X 12 mm	1
18	D704H011.1	CLUTCH	1
19	FP-0025	WASHER, M5	6
20	FS-0974	NUT, LOCK	3
21	BG-0280	BEARING, BALL	1
22	FR-0320	SPRING	1
23	D304H015.1	NUT	1
24	FS-0704	SCREW, M5 X 10 PAN HD S/STEEL	1
25	OB-0010	SEAL, OIL	2
26	D031H3007	BEARING, END	2
27	OA-0210	'O' RING	2
28	FS-0346	SCREW, M6 X 8 DOG POINT	2
29	BC-0070	RACE, THRUST	2
30	BC-0060	WASHER, THRUST	4
31	D304H013.1	GEAR, FEEDSHAFT	1
32	D304H035.1	PIN, CLIP HINGE	1

(Contd)

APRON WORM GEARING

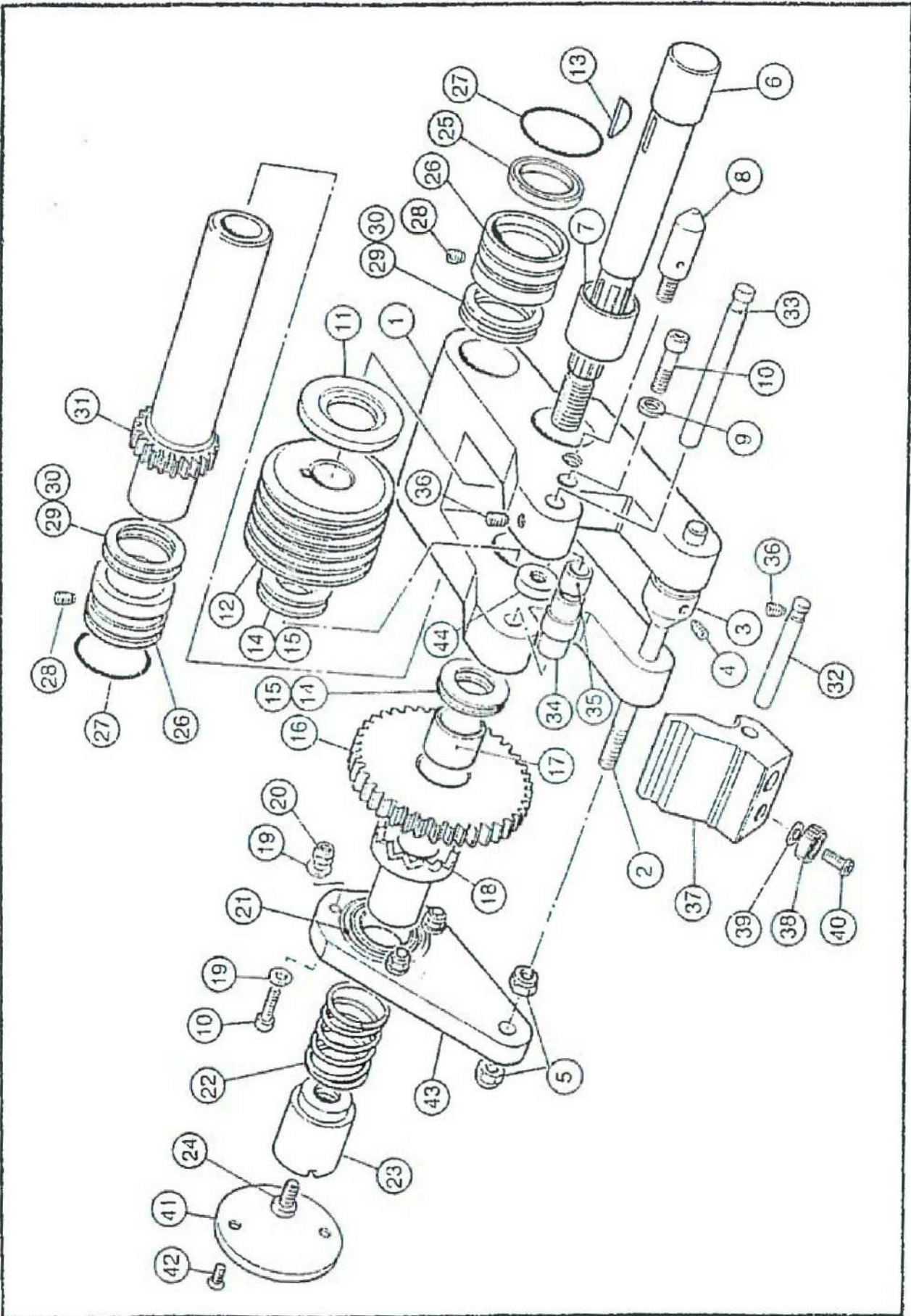

APRON WORM GEARING - Contd

ITEM	PART No	DESCRIPTION	QTY
33	D704H008.1	PIN, LOCATING BUSH	1
34	D904H025.1	CLIP, LOCATING BUSH	1
35	D704H047.1	SPACER	1
36	FS-0490	SCREW, M5 X 6 CUP POINT	2
37	D304H043.1	CLIP, WORM BOX, LH	1
37	D304H044.1	CLIP, WORM BOX, RH	1
38	BG-0290	BALL BEARING	1
39	FP-0030	WASHER, M5 BRIGHT	1
40	FS-0286	SCREW, M5 X 12 BUTTON HD	1
41	D304H025.1	DISC, ACCESS	1
42	FS-0424	SCREW, M4 X 8 C/SUNK SOCKET	2
43	D704H004.1	PLATE,TRIP	1
44	D704H045.1	WASHER,TRIP	1

LUBRICATING OIL PUMP

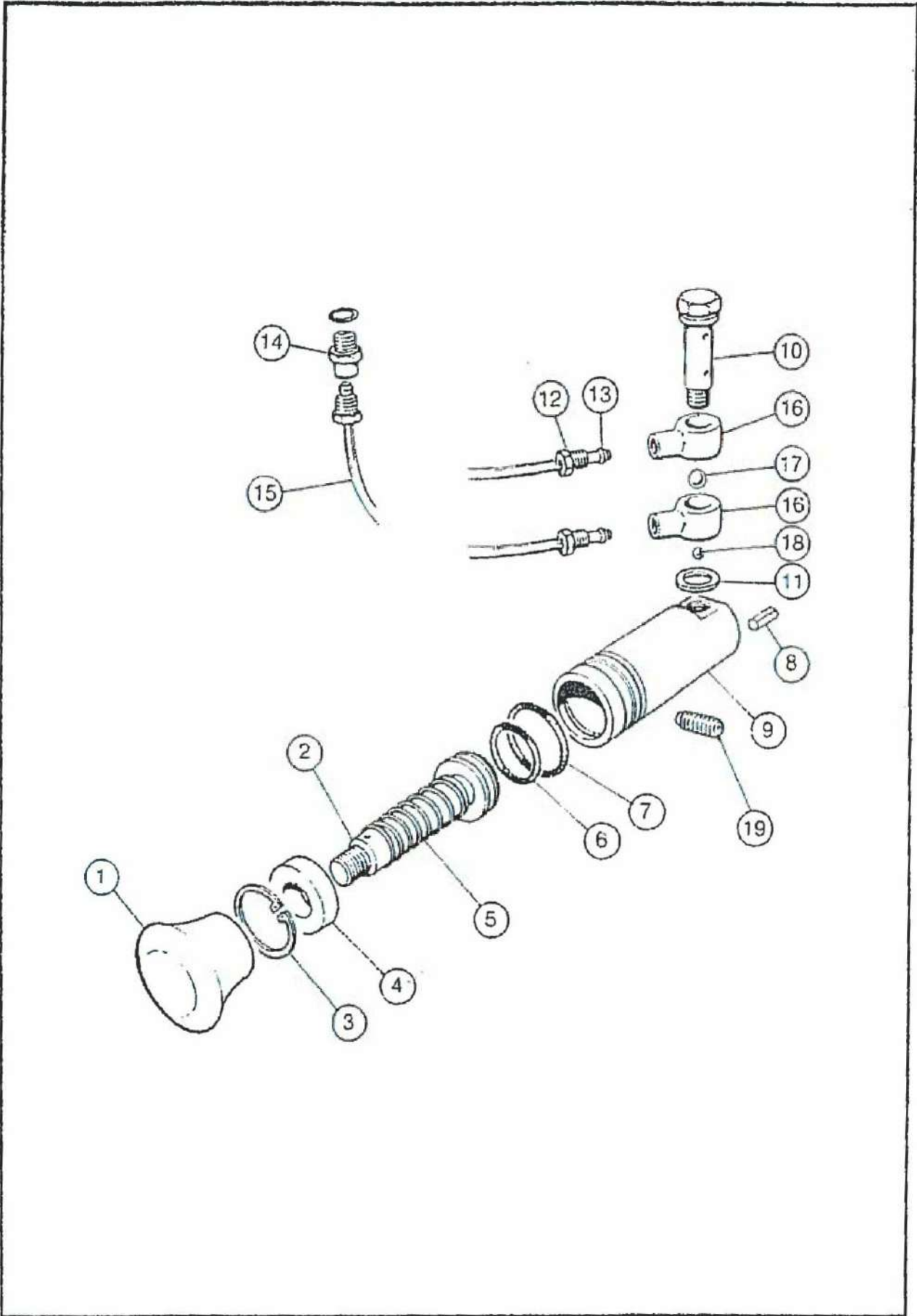

LUBRICATING OIL PUMP

ITEM	PART No	DESCRIPTION	QTY
1	HA-0040	KNOB, BLACK	1
2	D230H1015	PISTON	1
3	RA-0270	CIRCLIP, INTERNAL	1
4	D001H1010	CAP, END	1
5	FR-0003	SPRING	1
6	OA-0070	'O' RING (SMALL)	1
7	OA-0120	'O' RING (LARGE)	1
8	D404H039.1	PIN	1
9	D231H2001	BODY, PUMP	1
10	D304H039.1	BOLT, BANJO	2
11	PA-0200	WASHER, SEALING	5
12	PA-0230	NUT, TUBING	4
13	PA-0220	SLEEVE, TUBING	4
14	PA-0050	ADAPTOR	2
15	PF-0010	TUBE, NYLON	2
16	PA-0185	BANJO, BODY	1
17	UB-0007	BALL, STEEL, 7 mm	1
18	UB-0005	BALL, STEEL, 5 mm	1
19	FS-0368	SCREW, DOG POINT, M8 X 16	1

THREAD DIAL INDICATOR

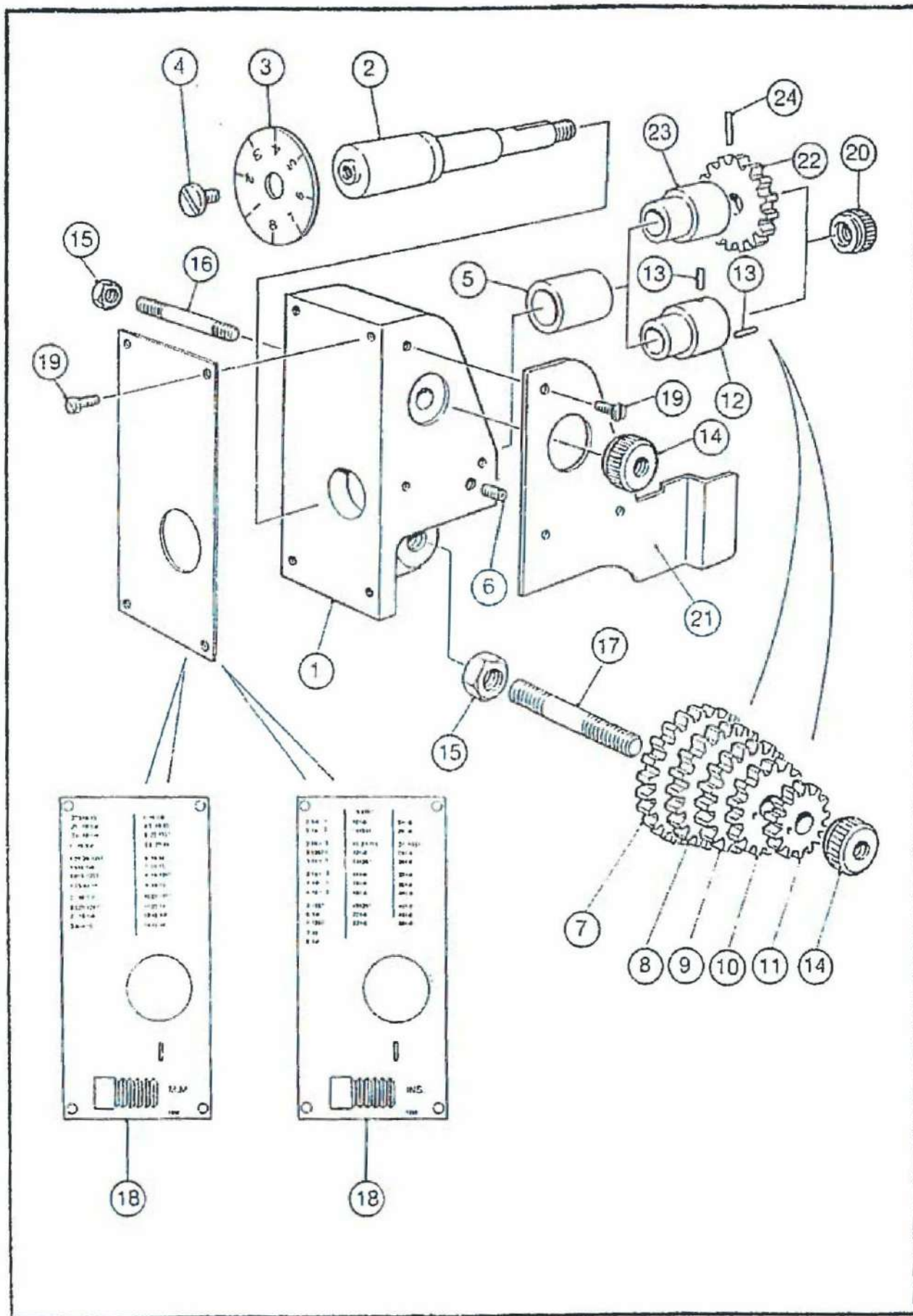

THREAD DIAL INDICATOR

ITEM	PART No	DESCRIPTION	QTY
	A143-0509	THREAD DIAL INDICATOR ASSEMBLY (METRIC)	1
1	D704H077.1	HOUSING	1
2	D704H078.1	SPINDLE	1
3	D001H3036	DIAL	1
4	FS-0704	SCREW, M5 X 10 PAN HD	1
5	BE-0080	BEARING, OILITE	1
6	FS-0344	SCREW, M5 X 12 DOG POINT	1
7	D301H3026	GEAR, 22 TEETH	1
8	D301H3025	GEAR, 20 TEETH	1
9	D301H3024	GEAR, 18 TEETH	1
10	D301H2016	GEAR, 16 TEETH	1
11	D301H2015	GEAR, 14 TEETH	1
12	D704H080.1	SPACER, METRIC	1
13	FT-0647	PIN, MILLS 3 mm X 10	2
14	D112H2008	NUT, KNURLED	2
15	FS-1040	LOCKNUT, M8	2
16	D250H0003	STUD	1
17	D704H079.1	STUD	1
18	NA-1358	PLATE, METRIC	1
19	B123-6024	SCREW, SELF-TAPPING, PAN HD, No 4 X 1/4in.	7
20	D704H083.1	NUT, KNURLED	1
21	D704H095.1	COVER	1
-	A143-0510	THREAD DIAL INDICATOR ASSEMBLY (ENGLISH)	1
1	D704H077.1	HOUSING	1
2	D704H078.1	SPINDLE	1
3	D001H3036	DIAL	1
4	FS-0704	SCREW, M5 X 10 PAN HD	1
5	BF-0080	BEARING OILITE	1
6	FS-0344	SCREW, M5 X 12 DOG POINT	1
14	D112H2008	NUT, KNURLED	1
15	FS-1040	LOCKNUT, M8	1
16	D250H0003	STUD	1
18	NA-1359	PLATE, IMPERIAL	1

(Contd)

THREAD DIAL INDICATOR

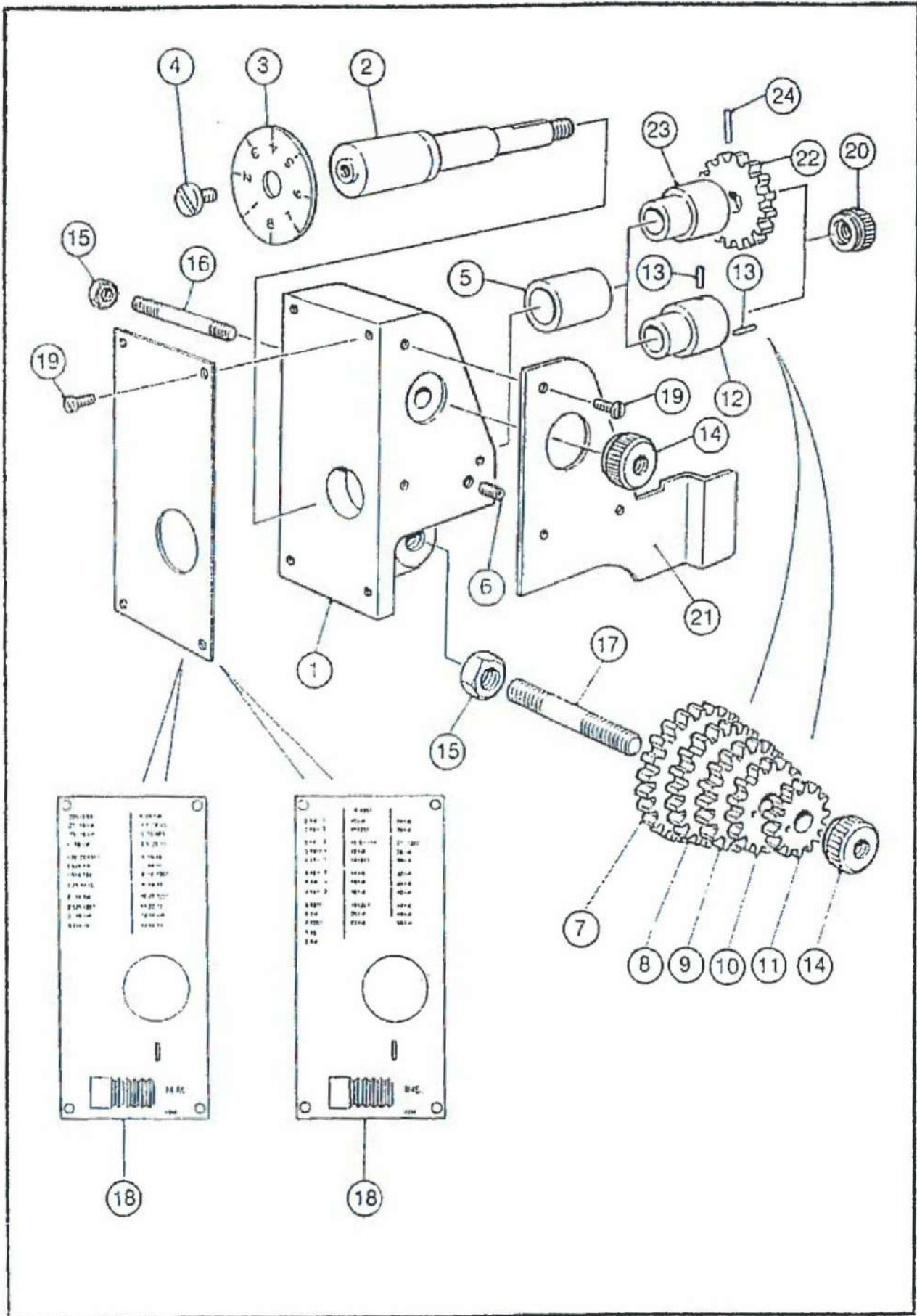

THREAD DIAL INDICATOR - Contd

ITEM	PART No	DESCRIPTION	QTY
19	B123-6024	SCREW, SELF TAPPING, No 4 X 1/4 in.	7
20	D704H083.1	NUT, KNURLED	1
21	D704H095.1	COVER	1
22	D301H3023	GEAR, 16 TEETH	1
23	D704H081.1	SPACER, ENGLISH	1
24	FT-0648	PIN, MILLS M3 X 12	1

SADDLE ASSEMBLY

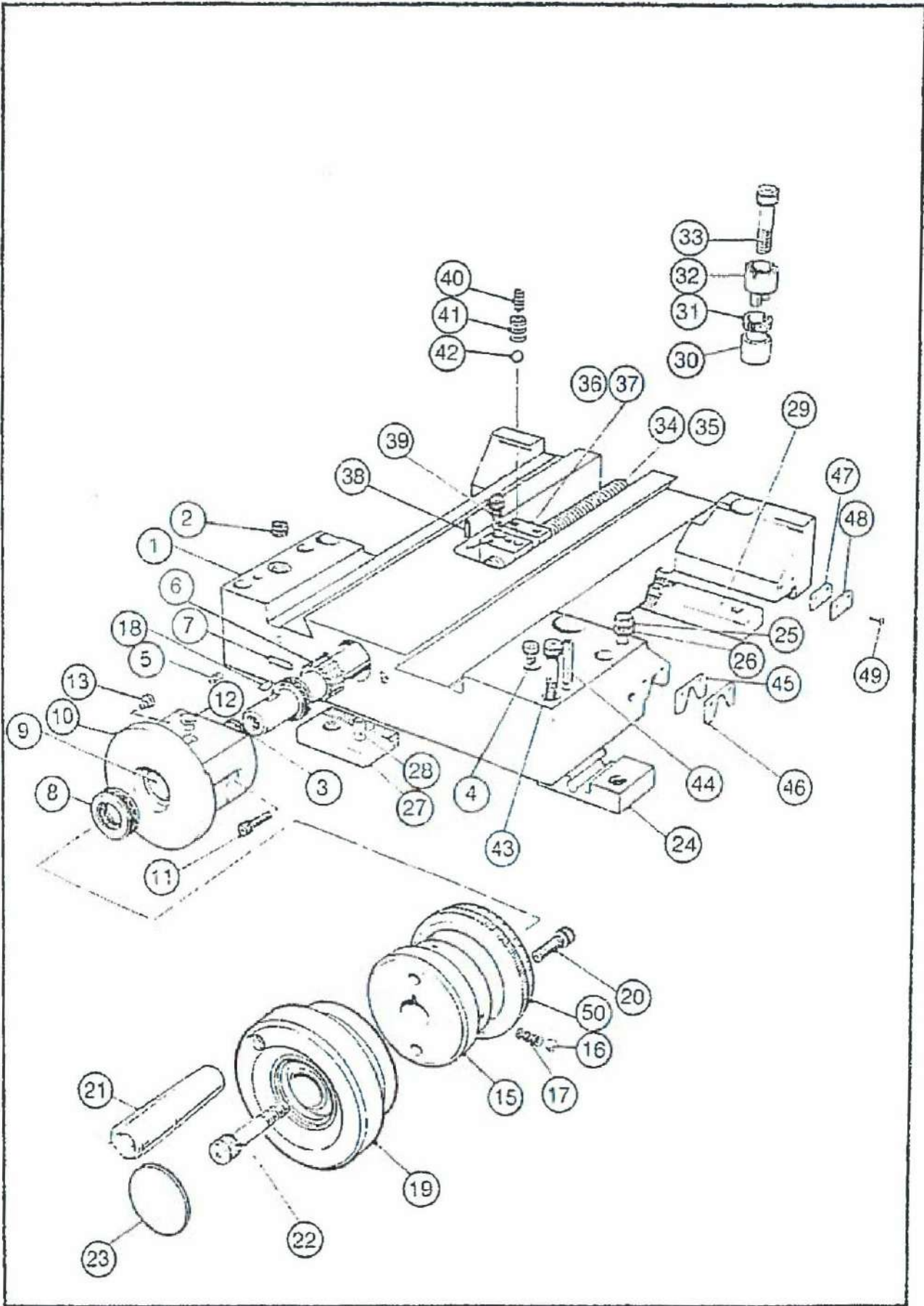

SADDLE ASSEMBLY

ITEM	PART No	DESCRIPTION	QTY
1	D305H004.1	SADDLE	1
2	PB-0110	PLUG, 1/2 in. BSP SKT	1
3	FP-0165	WASHER, M10	1
4	FS-0704	SCREW, M5 X 10 PAN HD, STAINLESS STEEL	1
5	FS-0498	SCREW, M6 X 8 CUP POINT	5
6	D301H2014	GEAR, DRIVE, 13 TEETH	1
7	FT-0250	PIN, M5 X 28 SPIROL	1
8	BG-0040	BEARING	2
9	BE-0100	BEARING, 25 X 20 OILITE	2
10	D305H005.1	HOUSING, BEARING	1
11	FS-0136	SCREW, M6 X 20 CAP HD SKT	2
12	OC-0010	NIPPLE, OIL 6mm DRIVE	1
13	ED-0265	GROMMET	1
14		NOT USED	
15	S2505C005	BOSS, HANDWHEEL	1
16	UB-0006	BALL, 6mm STEEL	3
17	FR-0005	SPRING, SG344	3
18	KA-0170	KEY, WOODRUFF	1
19	S2505C001	HANDWHEEL, CROSS SLIDE	1
20	FS-0140	SCREW, M6 X 30 CAP HD SKT	2
21	HB-0030	HANDLE, REVOLVING	1
22	FS-0770	SCREW, M8 X 30 CAP HD SKT	1
23	ED-1425	CAP, END	1
24	D800H2003	PLATE, CLAMP	1
25	FS-0596	BOLT, M10 X 70 HEX HD, HIGH TENSILE	1
26	FP-0060	WASHER, M10	1
27	D800H2005	PLATE, FRONT KEEP	1
28	FT-0340	PIN, M6 X 20 SPIROL	1
29	D905H012.1	PLATE, REAR KEEP	1
30	D101H1038	SLEEVE, ADJUSTING	4
31	D121H1007	SCREW, ADJUSTING	4
32	D111H1005	ADJUSTER, CLAMP	4
33	FS-0178	SCREW, M8 X 60 CAP HD SKT	4

(Contd)

SADDLE ASSEMBLY

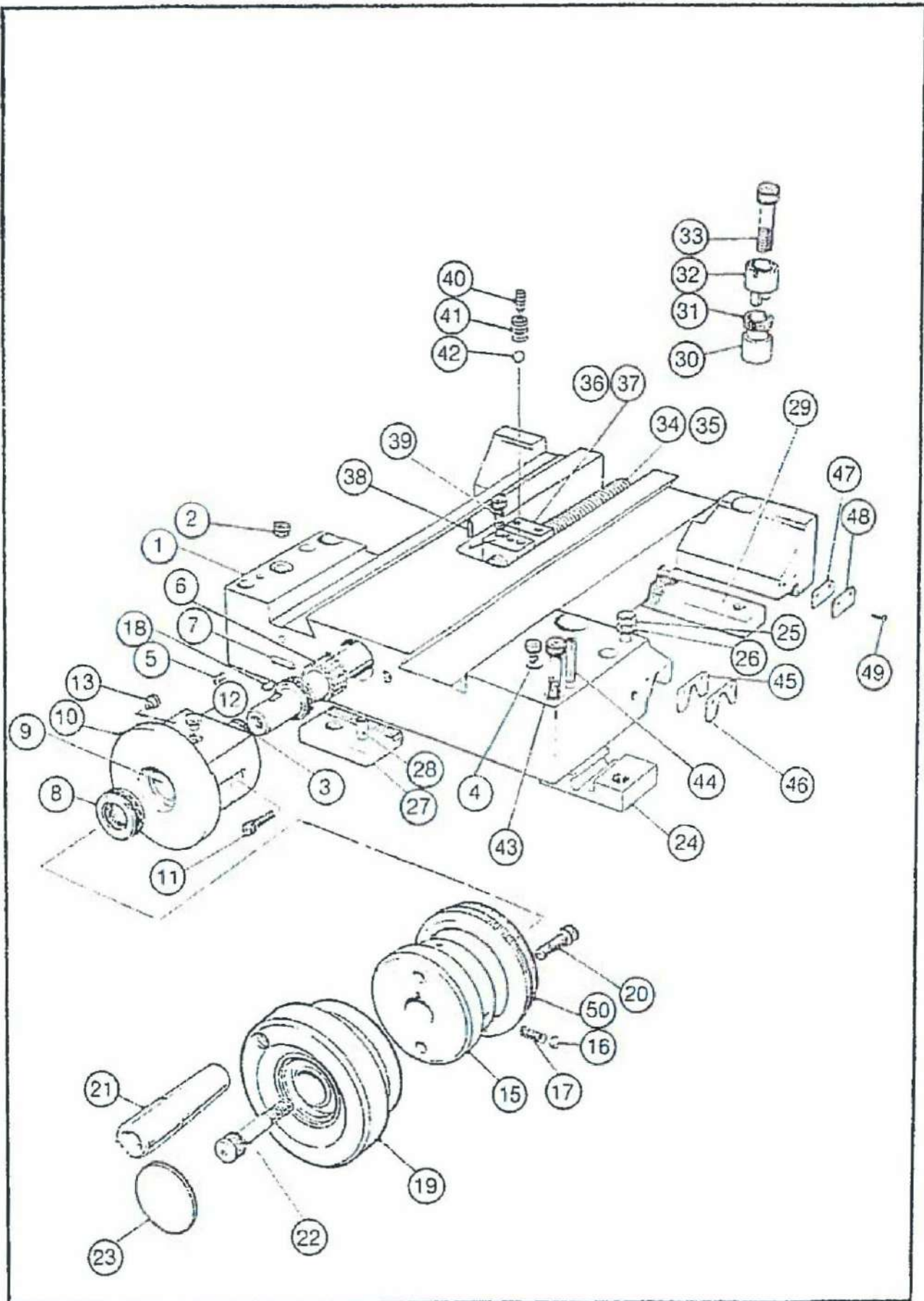

SADDLE ASSEMBLY - Contd

ITEM	PART No	DESCRIPTION		QTY
34	D305H015.1	SHAFT, SCREW, SADDLE METRIC	OR	1
35	D305H016.1	SHAFT, SCREW, SADDLE ENGLISH		1
36	D831H2004	NUT, SADDLE METRIC		1
37	D831H2005	NUT, SADDLE ENGLISH		1
38	FT-0350	PIN, M6 X 26 SPIROL		1
39	FS-0116	SCREW, M5 X 20 CAP HD SKT		4
40	FS-0862	SCREW		1
41	FR-0165	DISC, SPRING		3
42	UB-0008	BALL, STEEL		1
43	FS-0178	SCREW, M8 X 60 CAP HD SKT		4
44	FT-0460	PIN, SPIROL Ø 8 X 50		2
45	GB-0010	WIPER, VEE		2
46	GC-0010	BACKPLATE, WIPER		2
47	GB-0030	WIPER, SEAL		2
48	GC-0030	BACKPLATE		2
49	FS-0278	SCREW, M4 X 12 BUTTON HD SKT		8
50	SA-0060	DIAL, METRIC	OR	1
50	SA-0070	DIAL, ENGLISH		1

SLIDES ASSEMBLY

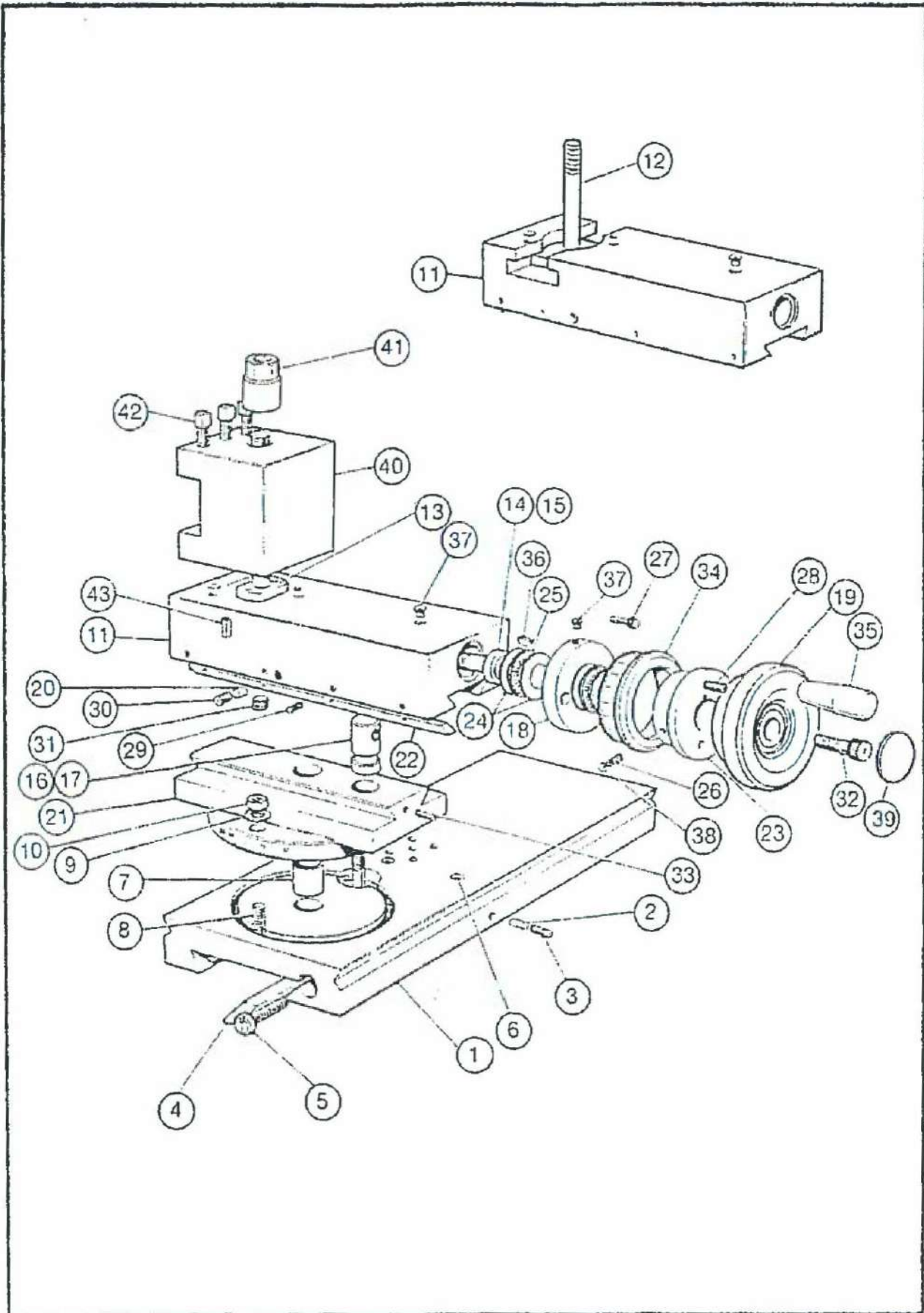

SLIDES ASSEMBLY

ITEM	PART No	DESCRIPTION	QTY
1	D678H7001	CROSS SLIDE	1
2	D100H0010	PIN LOCK	1
3	FS-0516	SCREW, M8 X 12 CUP POINT	1
4	D740H1002	STRIP, CROSS SLIDE	1
5	FS-0868	SCREW, ADJUSTING	2
6	OC-0010	NIPPLE, OIL, 6mm DRIVE	3
7	D110H1011	PIN, SWIVEL	1
8	D512H1001	BOLT, TEE	2
9	FP-0050	WASHER, M8	2
10	FS-0920	NUT, M8	2
11	D831H6002	TOP SLIDE, SOLID	1
		OR	
11	D831H6001	TOP SLIDE, TEE SLOTTED	1
12	A805H0101	TEE PIECE & STUD ASSY	1
13	D001H2091	RING, LOCATING	1
14	D282H1008	SCREW, TOP SLIDE (ENGLISH)	1
15	D282H1007	SCREW, TOP SLIDE (METRIC)	1
16	D517H1002	NUT, TOP SLIDE (ENGLISH)	1
17	D517H1001	NUT, TOP SLIDE (METRIC)	1
18	D001H5013	HOUSING, BEARING	1
19	S2505C002	BOSS, HANDLE	1
20	D100H0009	PAD, CLAMP	1
21	D664H7001	SLIDE, SWIVEL	1
22	D710H1001	STRIP	1
23	S2505C006	BAR, FINGER	1
24	BC-0030	WASHER, THRUST	4
25	BC-0040	RACE, THRUST	2
26	FR-0005	SPRING	3
27	FS-0114	SCREW, M5 X 16 CAP HD	2
28	FS-0116	SCREW, M5 X 20 CAP HD	2
29	FS-0504	SCREW, M6 X 16 CUP POINT	1
30	FS-0514	SCREW, M8 X 8 CUP POINT	1
31	FS-0526	SCREW, M12 X 12 CUP POINT	1
32	FS-0764	SCREW, M6 X 25 CAP HD NYLOC	1

(Contd)

SLIDES ASSEMBLY

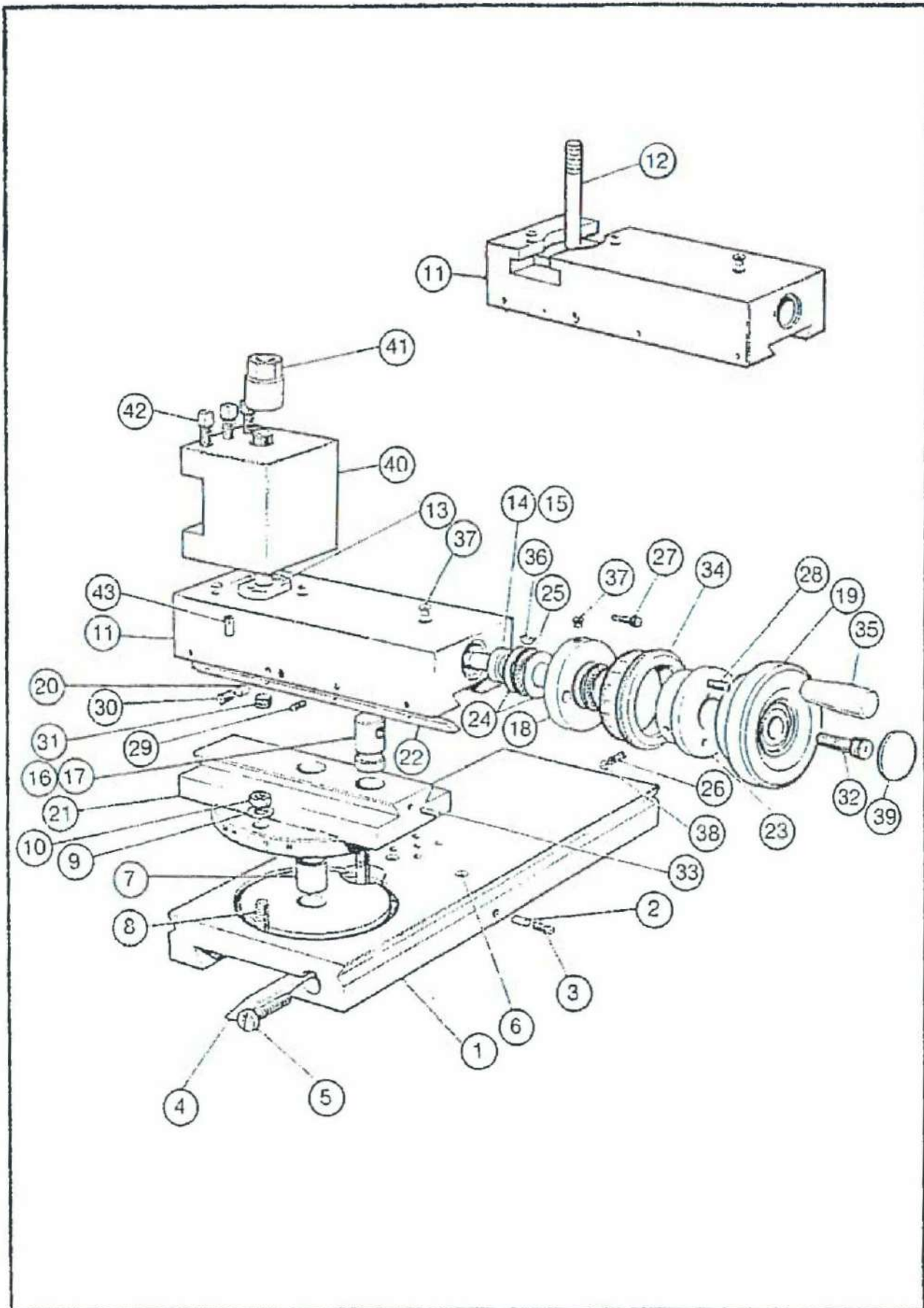

SLIDES ASSEMBLY - Contd

ITEM	PART No.	DESCRIPTION	QTY
33	FS-0786	M6 X 16 DOG POINT NYLOC SCREW	4
34	SA-0070	DIAL -- IMPERIAL	1
34	SA-0080	DIAL -- METRIC	1
35	HA-0140	KNOB	1
36	KA-0170	KEY, WOODRUFF	1
37	OC-0010	NIPPLE, OIL, 6mm drive	2
38	UB-0006	BALL, M6 STEEL	1
39	ED-1425	END CAP	1
41	D112H2010	TOOLPOST NUT	1
42	FS-0672	SCREW, CLAMP, M8 X 40	3
43	FT-0130	PIN, SPIROL, M4 X 16	2

SHAFTS RACK AND BRACKET ASSEMBLY

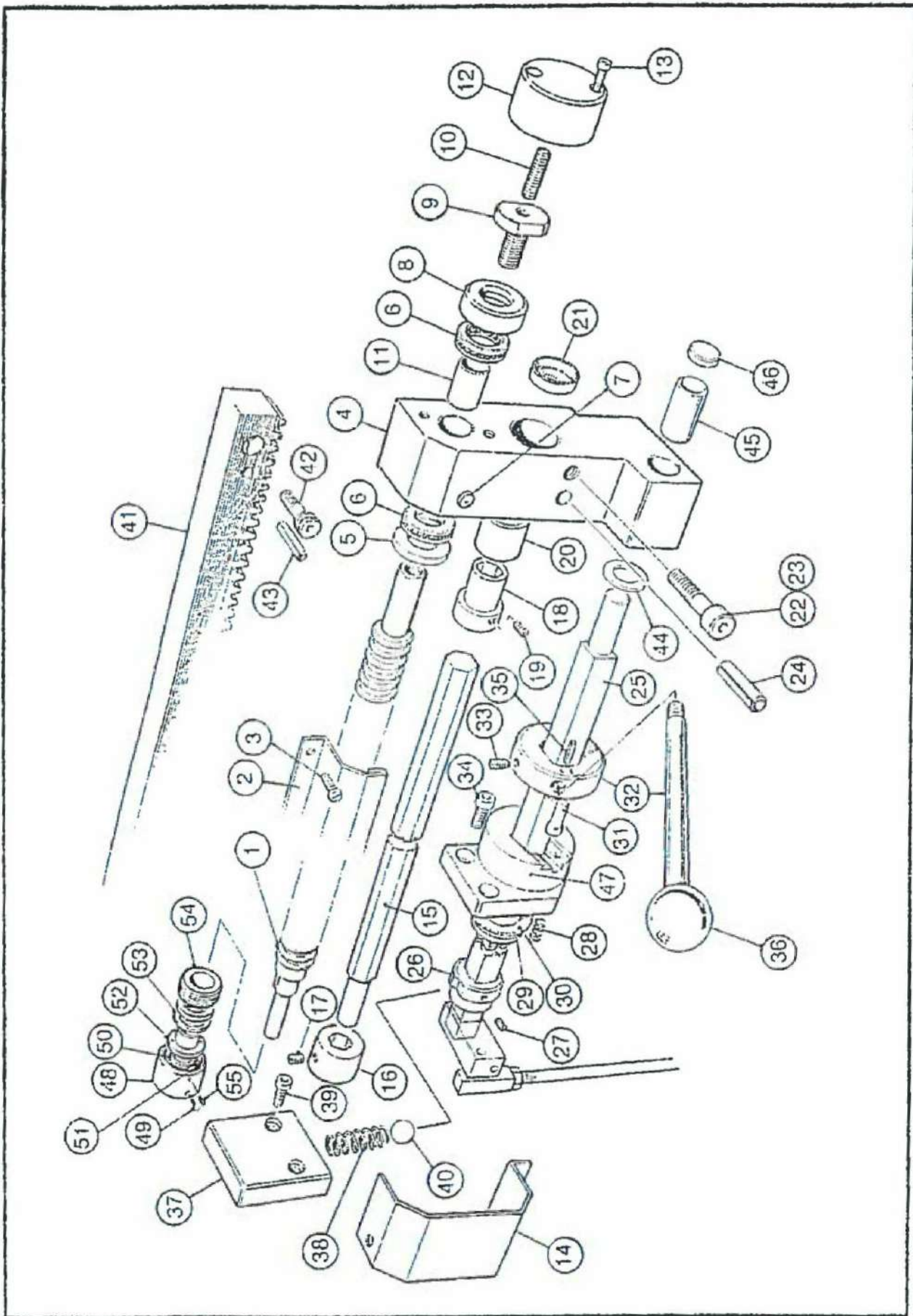

SHAFTS RACK AND BRACKET ASSEMBLY

ITEM	PART No.	DESCRIPTION	QTY
1	D282H2020P	LEADSCREW, METRIC 25"	1
1	D282H2021P	LEADSCREW, METRIC 40"	1
1	D282H2022P	LEADSCREW, IMPERIAL 25"	1
1	D282H2023P	LEADSCREW, IMPERIAL 40"	1
2	D306H032.3	COVER 25"	1
2	D306H033.3	COVER 40"	1
3	FS-0704	M5 X 10 PAN HEAD SCREW	2
4	D306H029.1	END BRACKET	1
5	D001H2072	SPACER	1
6	BG-0040	BEARING	2
7	OC-0010	NIPPLE OIL 6mm DRIVE	1
8	D001H2087	COVER	1
9	D122H2001	LOCKSCREW	1
10	FS-0508	M6 X 25 CUP POINT SCREW	1
11	BF-0090	BEARING	1
12	D306H037.1	COVER	1
13	FS-0089	M3 X 25 CAP HEAD SCREW	2
14	D306H034.1	COVER	1
15	D210H1036	FEEDSHAFT 25"	1
15	D210H1037	FEEDSHAFT 40"	1
16	D306H036.1	COUPLING	1
17	FS-0558	M5 X 8 CUP POINT SCREW	1
18	D001H2104	COLLAR	1
19	FS-0496	M6 X 6 CUP POINT SCREW	1
20	BF-0145	BEARING	1
21	D000H2005	PLUG	1
22	FS-0170	M8 X 40 CAP SCREW	1
23	FS-0176	M8 X 55 CAP SCREW	1
24	FT-0850	PIN, SPIROL M8 X 65	2
25	D551H1006	THIRD SHAFT 25"	1
26	D551H1007	THIRD SHAFT 40"	1

SHAFTS RACK AND BRACKET ASSEMBLY

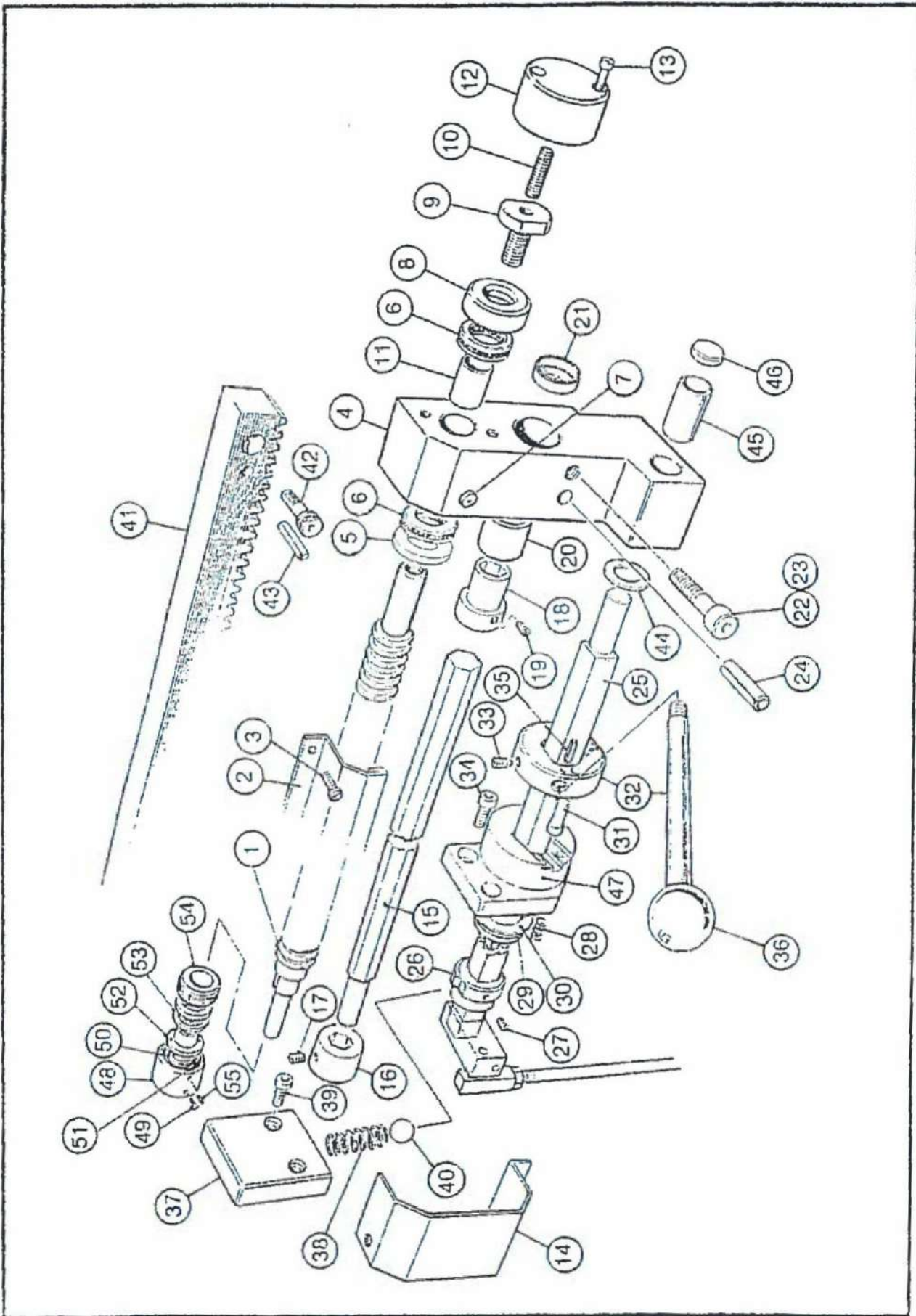

SHAFTS RACK AND BRACKET ASSEMBLY - Contd

ITEM	PART No.	DESCRIPTION	QTY
26	D306H041.1	DETENT BUSH	1
27	FS-0498	M6 X 8 CUP POINT SCREW	1
28	FR-0004	SPRING	1
29	D111H2029	CENTRE	1
30	BC-0120	WASHER, THRUST	1
31	D906H053.1	PEG	1
32	A306H001.1	LEVER, BOSS ASSEMBLY	1
33	FS-0134	M6 X 18 DOG POINT SCREW	1
34	FS-0134	M6 X 16 CAP HEAD SCREW	2
35	FT-0090	PIN. SPIROL M3 X 18	1
36	HA-0030	HANDLE	1
37	D306H040.1	HOUSING, SPRING	1
38	FR-0440	SPRING, COMPRESSING	1
39	FS-0138	M6 X 25 CAP HEAD SCREW	2
40	UB-0016	BALL, STEEL 16MM	1
41	D306H030.1	RACK 25"	1
41	D306H031.1	RACK 40"	1
42	FS-0140	M6 X 30 CAP HEAD SCREW	6
43	FT-0260	PIN, SPIROL M5 X 30	6
44	FP-0070	WASHER, BRIGHT	1
45	BE-0080	BEARING, OILITE	1
46	D000H1004	PLUG	1
47	D906H0035.1	THIRD SHAFT BOSS	1
48	D102H3004	HOUSING	1
49	FS-0426	SCREW COUNTERSUNK M4 X 10	2
50	D001H2082	RING INNER	1
51	UB-0006	BALL, STEEL 6MM	2
52	D111H2020P	SLEEVE, FRICTION	1
53	FR-0201	SPRING, DISC	18
54	D021H3001	NUT, ADJUSTING	1
55	FS-0486	M4 X 4 CUP POINT SCREW	2

TAILSTOCK ASSEMBLY

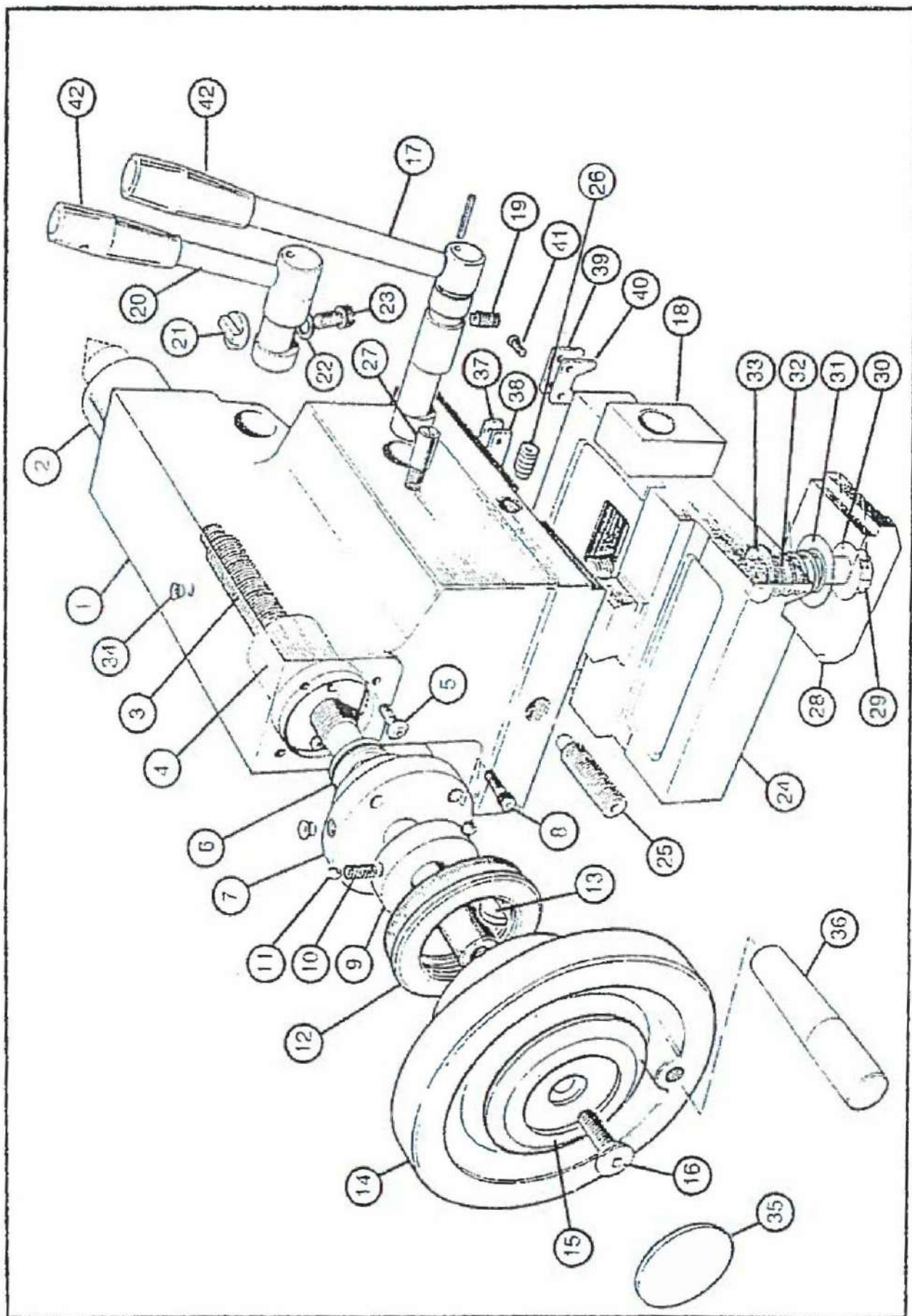

TAILSTOCK ASSEMBLY

ITEM	PART No	DESCRIPTION	QTY
	MB-ZB-0010	TAILSTOCK ASSEMBLY	1
1	D307H007.1/V	BODY	1
2	D207H3005	QUILL	1
3	D282H1001	SCREW - METRIC OR	1
3	D282H1002	SCREW - IMPERIAL	1
4	D118H3003	NUT - METRIC OR	1
4	D118H3004	NUT - IMPERIAL	1
5	FS-0290	SCREW M5 X 26 BUTTON HD SKT	2
6	BG-0040	BEARING	1
7	D111H5007	BUSH - REAR	1
8	FS-0116	SCREW, M5 X 20 CAP HD SKT	4
9	D001H3035	RING, DETENT	1
10	FR-0005	SPRING	3
11	UB-0006	BALL, STEEL	3
12	SA-0070	DIAL, ENGLISH OR	1
12	SA-0080	DIAL, METRIC	1
13	KA-0180	KEY, WOODRUFF	1
14	S2504C007	HANDWHEEL	1
15	S2504C008	SPACER	1
16	FS-0784	SCREW, M8 X 20 C/SUNK NYLOC	1
17	A801H0103	CLAMP, BED ASSY	1
18	D800H2002	BLOCK	1
19	FS-0796	SCREW, M8 X 20 FULL DOG POINT NYLOC	1
20	A801H0104	CLAMP, QUILL ASSY	1
21	D000H2004	KEY, QUILL	1
22	FP-0040	WASHER, BRIGHT, M6	1
23	FS-0130	SCREW, M6 X 10 CAP HD SKT	1
24	D820H7002	BASE	1
25	FS-0892	SCREW, M12 X 50 SKT SET - SPHERICAL POINT	1
26	FS-0377	SCREW, M10 X 50 DOG POINT	2
27	S2507C006	PIN, STOP	1
28	D820H5001	PLATE, CLAMP	1
29	FS-0756	BOLT, M16 X 100 HEX HD NYLOC	1

(Contd)

TAILSTOCK ASSEMBLY

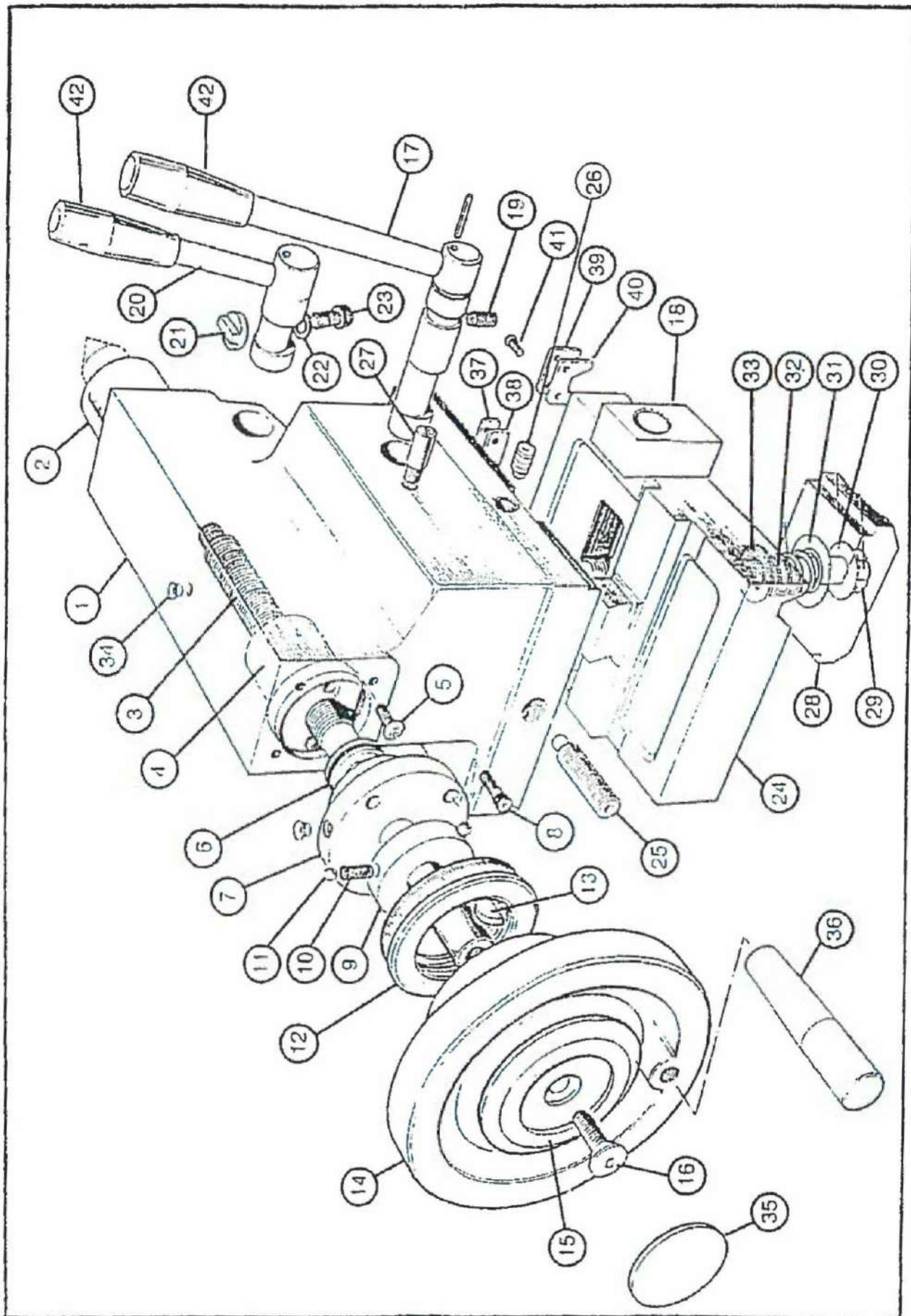

TAILSTOCK ASSEMBLY - Contd

ITEM	PART No	DESCRIPTION	QTY
30	D001H2099	WASHER, CLAMPING	1
31	D001H3037	WASHER, RETAINING	1
32	FR-0011	SPRING	1
33	FP-0090	WASHER, M16 BRIGHT	1
34	OC-0010	NIPPLE, OIL 6mm DRIVE-IN	2
35	ED-1425	CAP, PLASTIC	1
36	HB-0030	HANDLE, REVOLVING	1
37	GC-0030	WIPER COVER (FLAT)	1
38	GB-0030	WIPER, FLAT	1
39	GC-0020	WIPER COVER (VEE)	1
40	GB-0020	WIPER, VEE	1
41	FS-0278	SCREW, M4 X 12 BUTTON HD SKT	4
42	HA-0180	HANDLE	2

CHANGEWHEELS

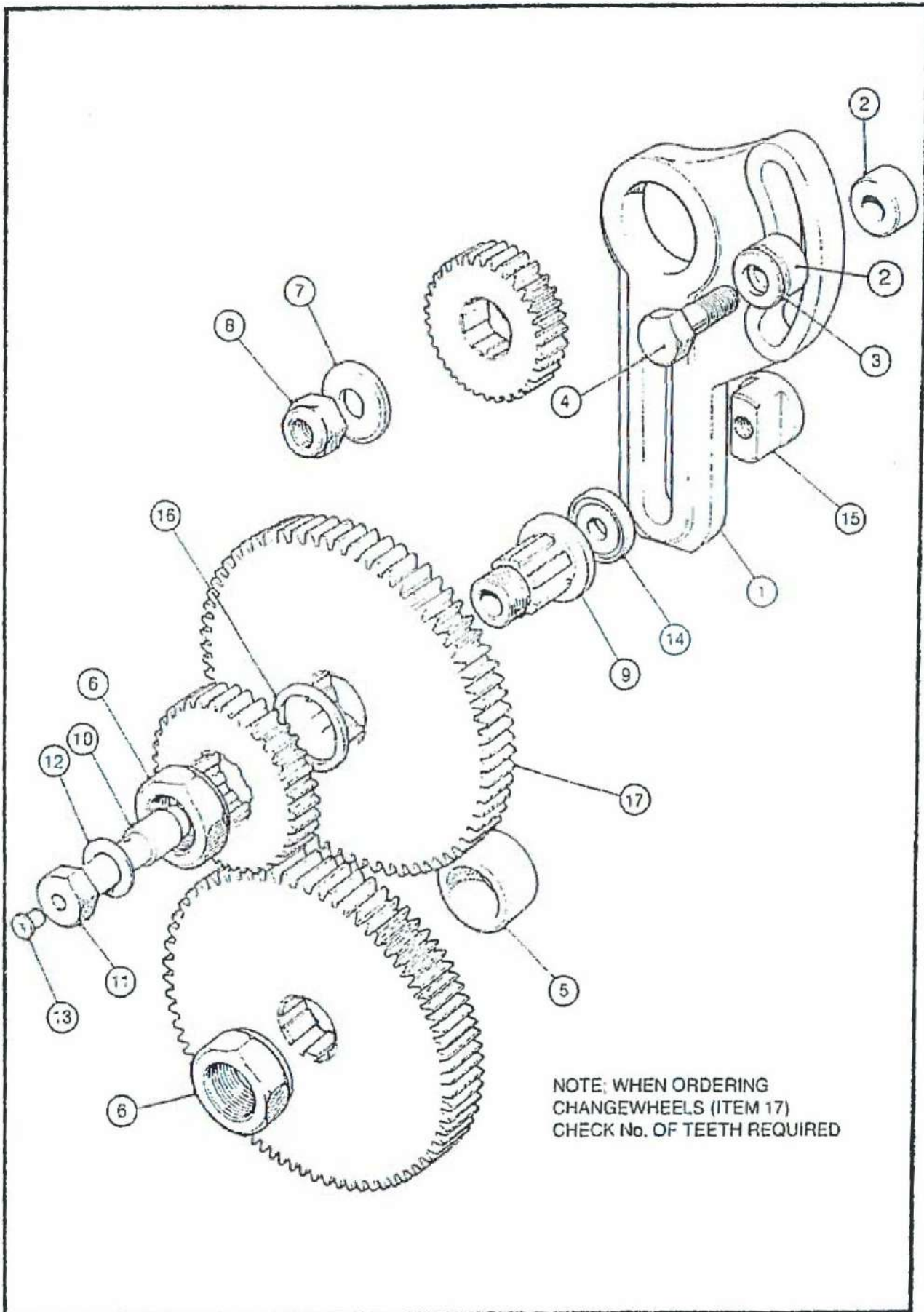

NOTE: WHEN ORDERING
CHANGEWHEELS (ITEM 17)
CHECK No. OF TEETH REQUIRED

CHANGEWHEELS

ITEM	PART No	DESCRIPTION	QTY
1	D661H6001	FRAME, SWING	1
2	D101H2095	SPACER, SWING FRAME	2
3	FP-0165	WASHER, M10	1
4	FS-0596	BOLT, M10 X 70 HEX HD, HIGH TENSILE	1
5	D101H2096	SPACER	1
6	FS-0954	NUT, CHANGEWHEEL	2
7	D001H2077	WASHER	1
8	FS-0938	NUT, 10mm	1
9	D121H2007	BUSH, CHANGEWHEEL	1
10	BF-0070	BEARING, GLACIER	2
11	D507H1001	STUD, CHANGEWHEEL	1
12	D001H1008	SPACER	1
13	OC-0010	NIPPLE, OIL, 6mm DRIVE	1
14	D001H2076	SPACER	1
15	D112H2007	NUT, CHANGEWHEEL	1
16	D001H2075	SPACER	1
17	M308	CHANGEWHEELS, COMMON TO METRIC & ENGLISH	1
	D301H5015	CHANGEWHEEL, 44 TEETH	1
	D301H6045	CHANGEWHEEL, 56 TEETH	1
	UA-0030	CHANGEWHEEL, 88 TEETH	1
	M308/M	CHANGEWHEELS, METRIC MACHINES ONLY	1
	UA-0010	CHANGEWHEELS, 96 TEETH	1
	NA-1440	M300 AUXILIARY THREAD PLATE (BLACK)	1
	NA-1439	M300 THREAD AND FEED PLATE (BLACK)	1
	B123-6024	SCREW PAN HD	4
	M308/E	CHANGEWHEEL, ENGLISH MACHINES ONLY	1
	D301H5014	CHANGEWHEEL, 40 TEETH	1
	UA-0040	CHANGEWHEEL, 84 TEETH	1
	UA-0020	CHANGEWHEEL, 95 TEETH	1
	M308/E-STD	CHANGEWHEELS, STANDARD	1
	NA-1437	M300 AUXILIARY THREAD PLATE (BLACK)	1

(Contd)

CHANGEWHEELS

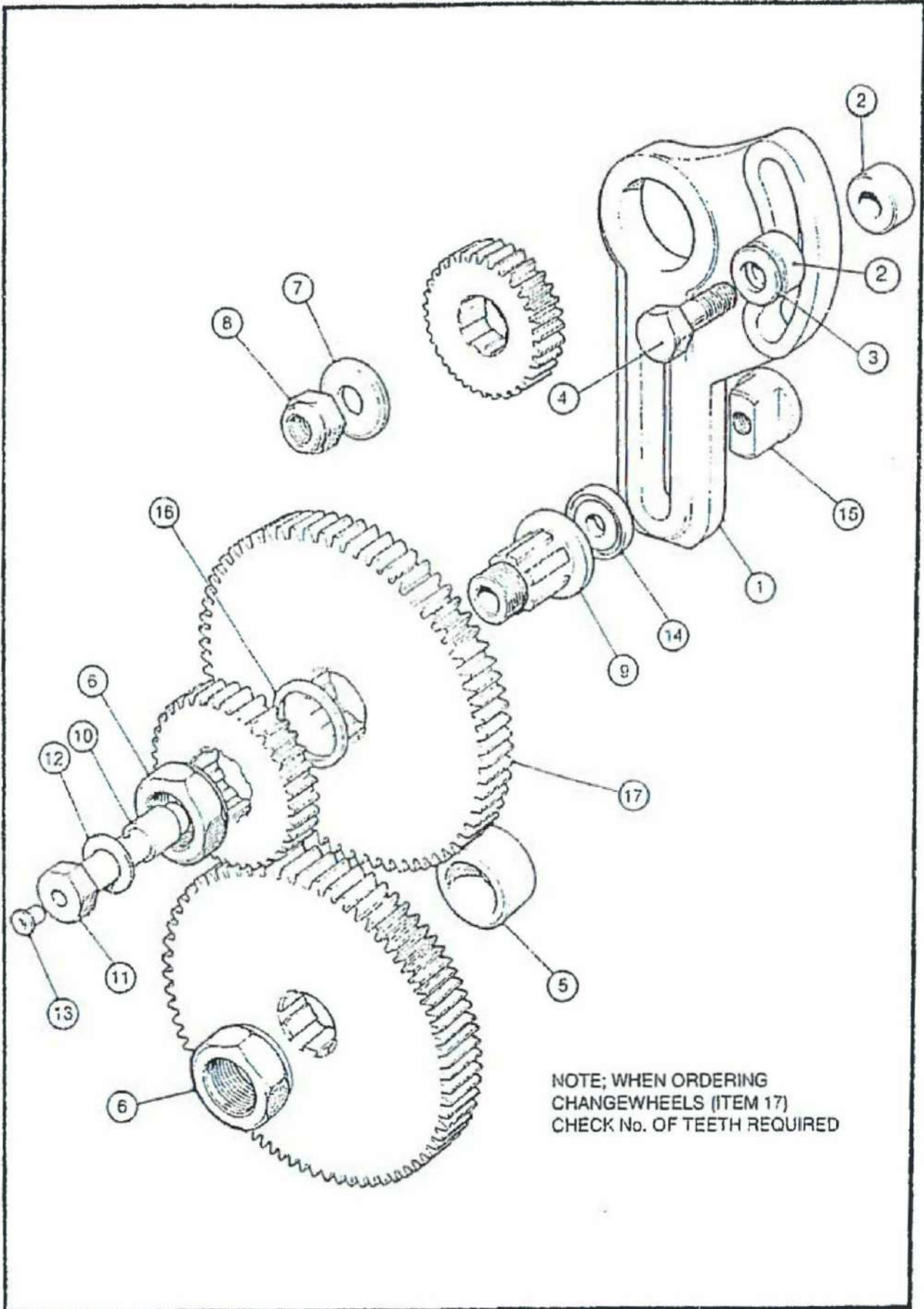

NOTE; WHEN ORDERING
CHANGEWHEELS (ITEM 17)
CHECK No. OF TEETH REQUIRED

CHANGEWHEELS - Contd

ITEM	PART No	DESCRIPTION	QTY
	NA-1441	M300 THREAD AND FEED PLATE (BLACK)	1
	B123-6024	SCREW, PAN HEAD	4
	M308/E-USA	CHANGEWHEELS, USA	1
	NA-1438	M300 AUXILIARY FEED PLATE (BLACK)	1
	NA-1437	M300 AUXILIARY THREAD PLATE (BLACK)	1
	NA-1154	1154 THREAD AND FEED PLATE	1
	FS-0854	SCREW, PAN HEAD	4

INTERLOCKED CHUCK GUARD

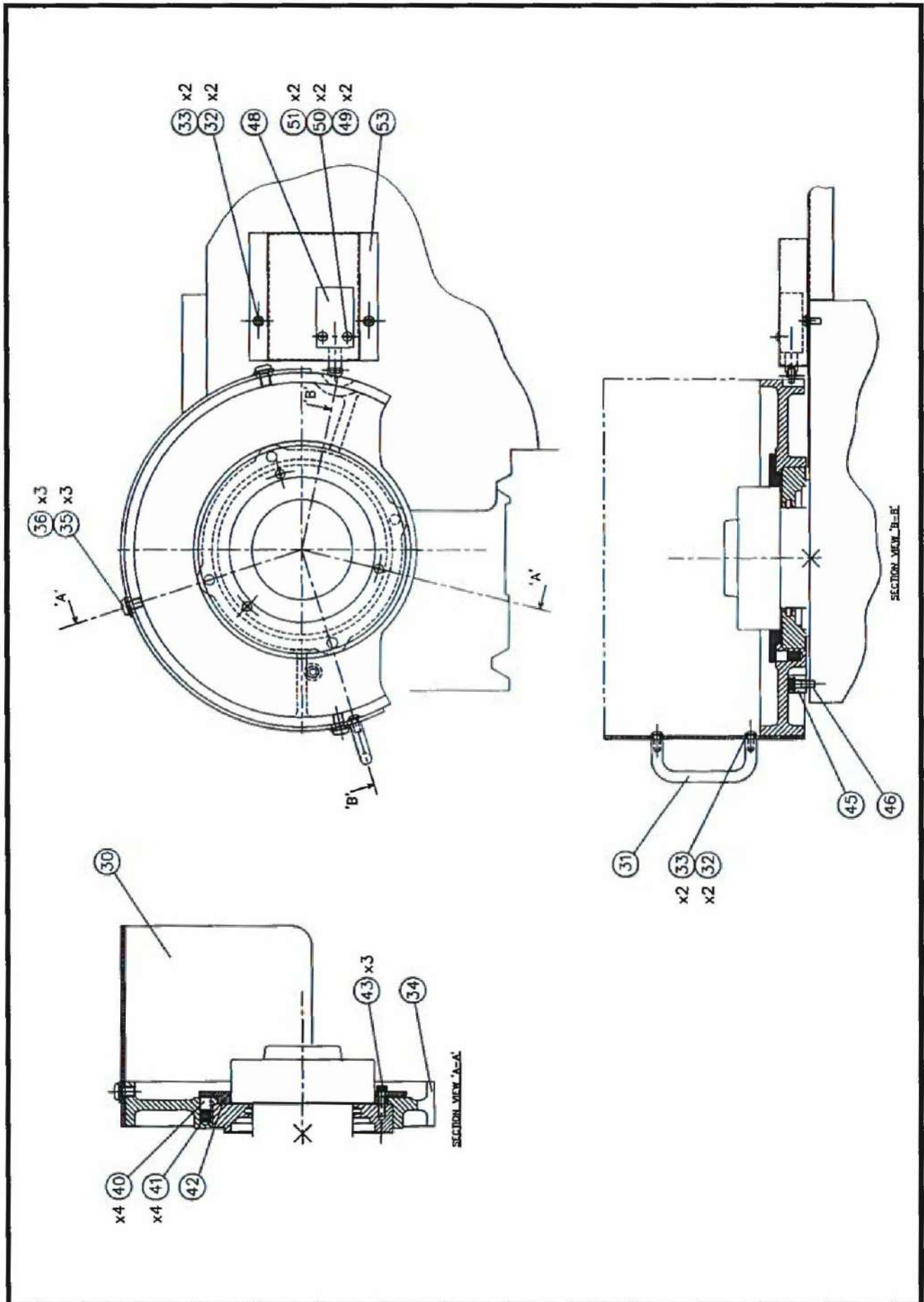

INTERLOCKED CHUCK GUARD

ITEM	PART No	DESCRIPTION	QTY
30	D311H015.1	CANOPY-CHUCK GUARD	1
31	HA-0110	M5 HANDLE	1
32	FS-0286	M5 X 12 BUTTON HEAD CAP SCREW	4
33	FP-0030	5MM BRIGHT STEEL WASHERS	4
34	D017H9-005	MOUNTING PLATE	1
35	FS-0302	M8 X 12 BUTTON HEAD CAP SCREW	3
36	FP-0050	M8 BRIGHT WASHER FORM A	3
40	BD-0050	8MM DIA. X 12 CYLINDRICAL ROLLERS	4
41	FR-0230	SPRING SG419 (FLEXO M165503)	4
42	D011H7-016	RETAINING PLATE	1
43	FS-0116	M5 X 20 SOCKET HEAD CAP SCREW	3
45	D311H002.1/V	STOP BUTTON	1
46	FS-0134	M6 X 16 SOCKET HEAD CAP SCREW	1
48	QF-0350	CHUCK GUARD HARNESS GA1005	1
49	FS-0098	M4 X 20 SOCKET HEAD CAP SCREW	2
50	FS-0963	M4 DOMED NUT	2
51	FP-0170	M4 STANDARD BRIGHT WASHER	2
53	S2511C002	SWITCH CASING	1

ADDITIONAL EQUIPMENT

4 WAYHAND INDEXING TOOL.....	105
QUICK CHANGE TOOLPOST.....	106
QUICK CHANGE PARTING OFF TOOLHOLD.....	106
RAISER BLOCK.....	106
AUXILARY REAR SLIDE.....	107
SINGLE TOOLPOST (FOR AUXILIARY REAR SLIDE).....	107
PERSPEX CHIP GUARD – SADDLE MOUNTING.....	108
COOLANT PUMP, TANK AND FITTINGS.....	109
LOW VOLTAGE MACHINE LIGHT.....	110
TRAVELLING STEADY.....	111
STATIONARY STEADY.....	112
5 POSITION STOP – CROSS-SLIDE TRAVERSE.....	113
SINGLE STOP – SADDLE TRAVERSE.....	113
MICROMETER STOP – SADDLE TRAVERSE.....	113
5 POSITION STOP – SADDLE TRAVERSE.....	113
APRON HANDWHEEL DIAL – METRIC GRADUATIONS.....	114
APRON HANDWHEEL DIAL – IMPERIAL GRADUATIONS.....	114

ITEMS AVAILABLE BUT NOT ILLUSTRATED

METRIC/IMPERIAL DUAL READING DIAL – CROSS-SLIDE
METRIC/IMPERIAL DUAL READING DIAL – TOP SLIDE
200mm HIGH SPEED 4 JAW INDEPENDANT CHUCK D1-4
160mm SUPER PRECISION 3 JAW GEARED SCROLL SELF-CENTERING
CHUCK D1-4
KC15 38mm BURNERD MULTISIZE KEY OPERATED COLLET CHUCK D1-4
EC2 TO EC13 SET OF 12 COLLETS, RANGE 1.6mm – 38mm
JACOB DRILL CHUCK No.3MT SHANK 12.7mm CAPACITY
300mm DIA FACEPLATE
460mm DIA FACEPLATE
38mm MULTISIZE LEVER OPERATED COLLET CHUCK, DIRECT MOUNTING
REAR SPLASH GUARD 25" OR 40" CENTRES
MILLING/DRILLING ATTACHMENT
TOOLPOST GRINDER

4-WAY HAND-INDEXING TOOLPOST

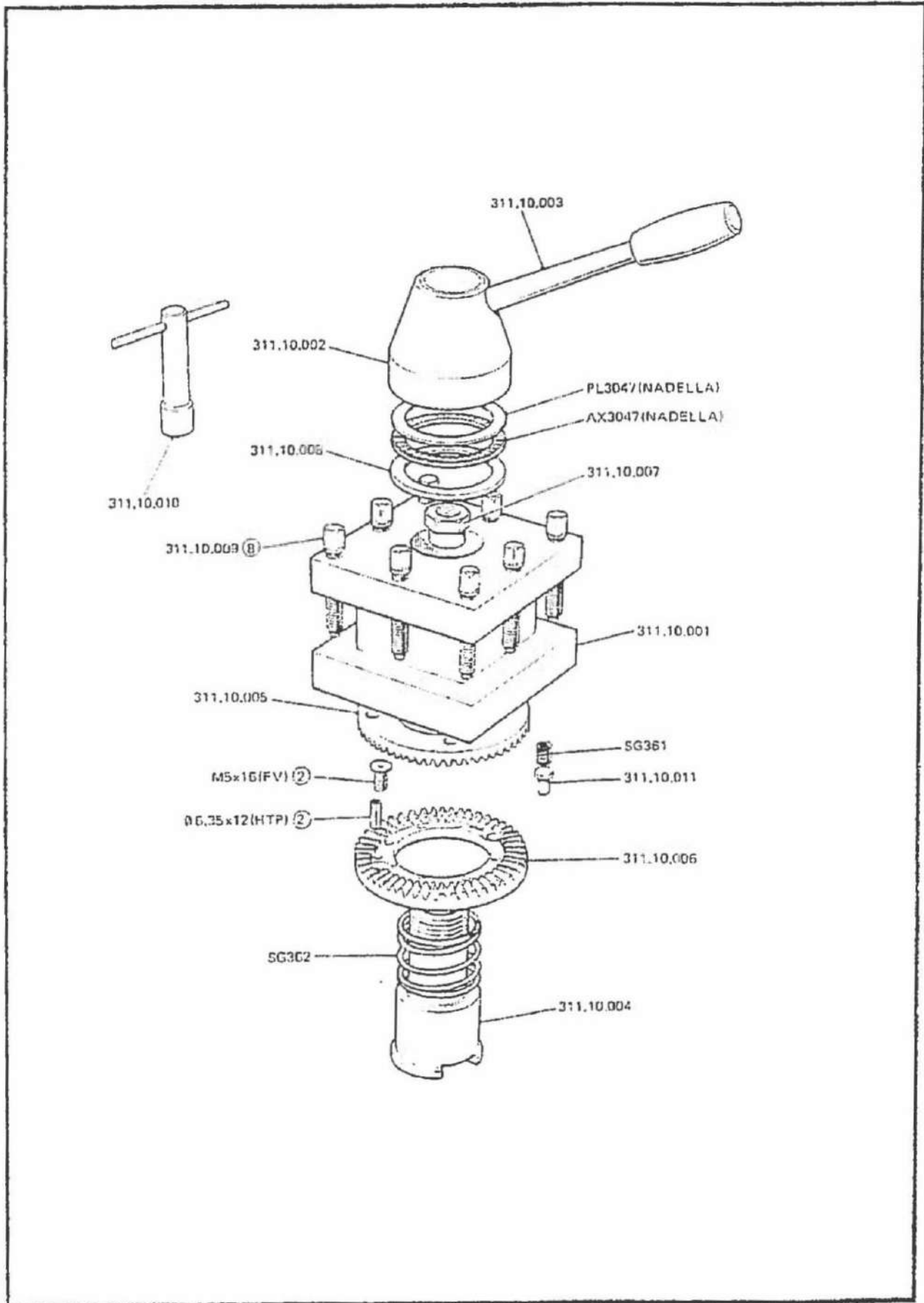

QUICK CHANGE TOOLPOST

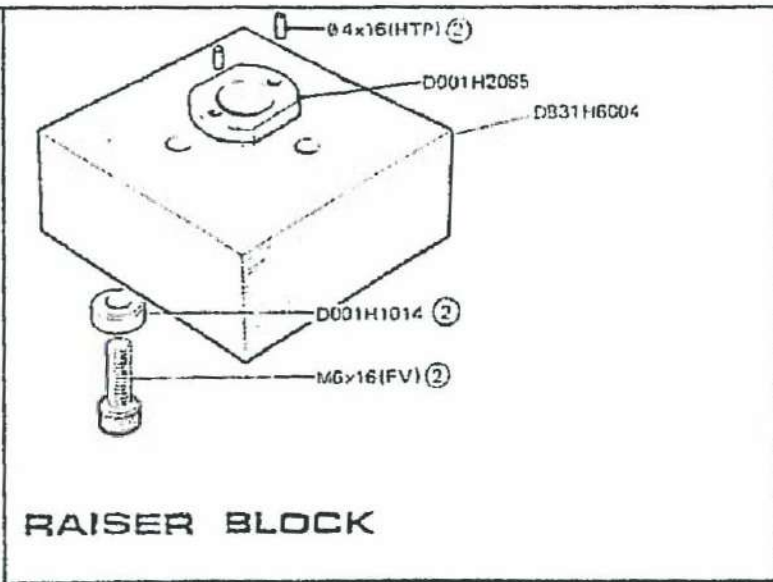
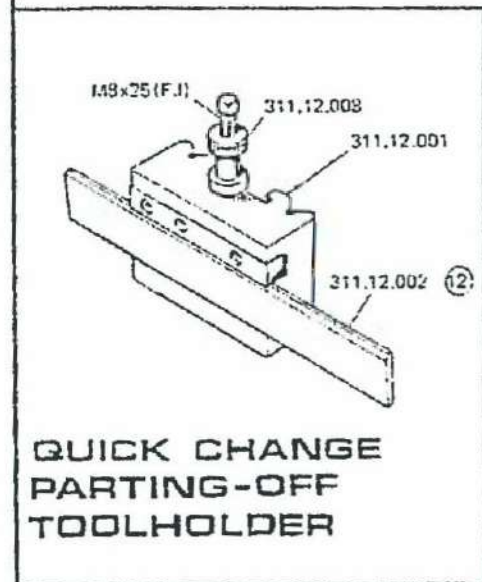
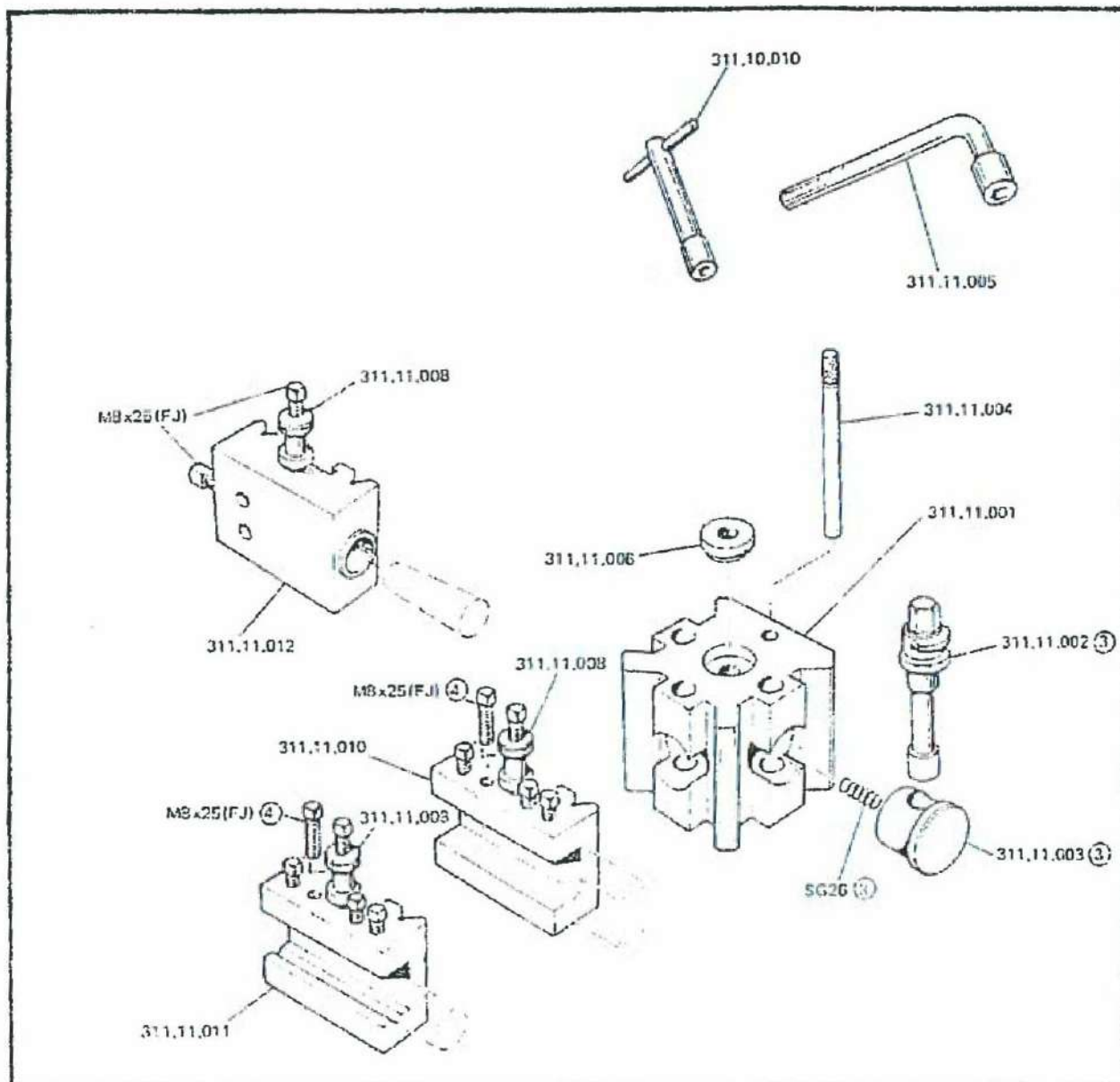

SINGLE TOOLPOST AND AUXILIARY REAR SLIDE

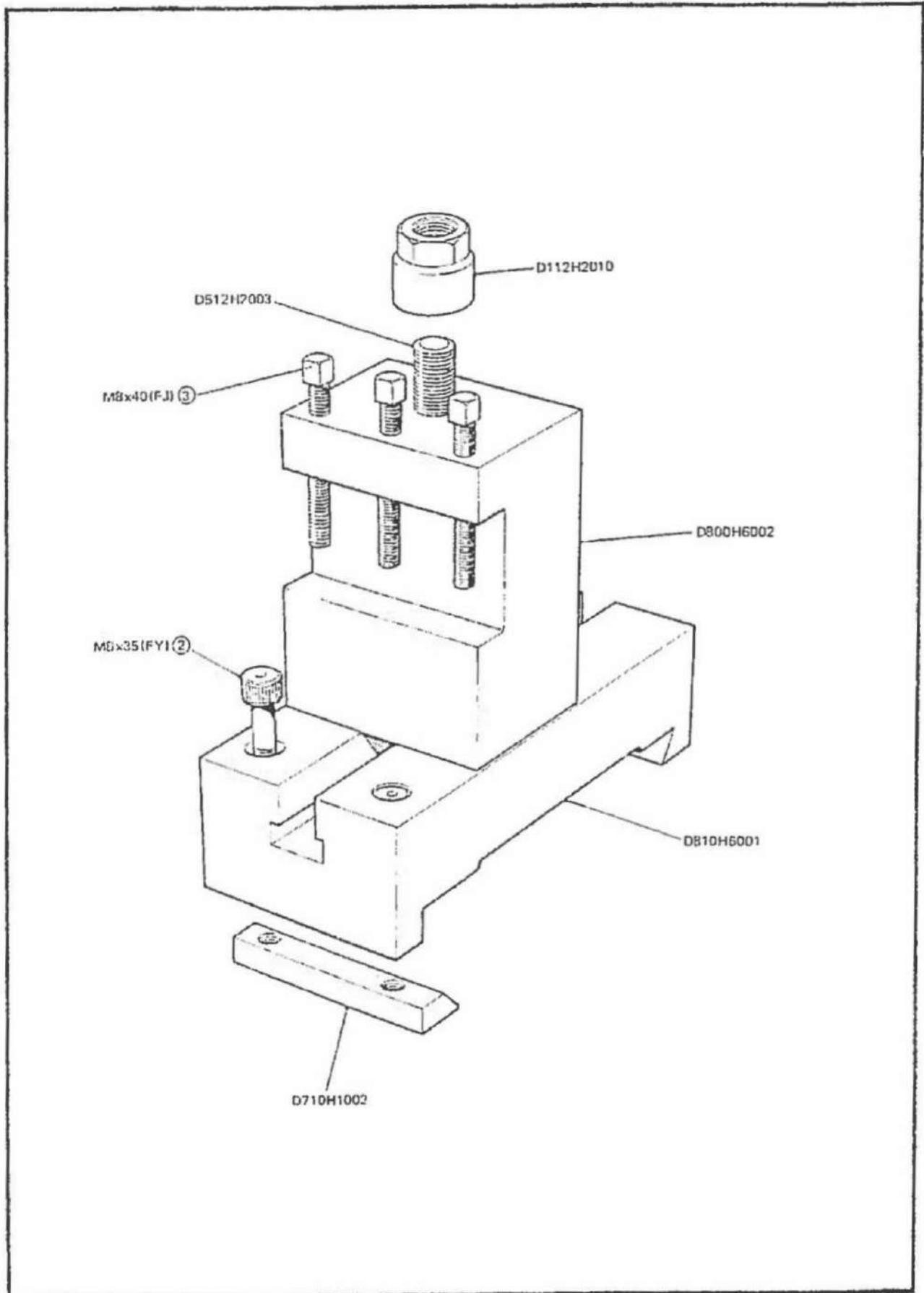

PERSPEX CHIPGUARD - SADDLE MOUNTING

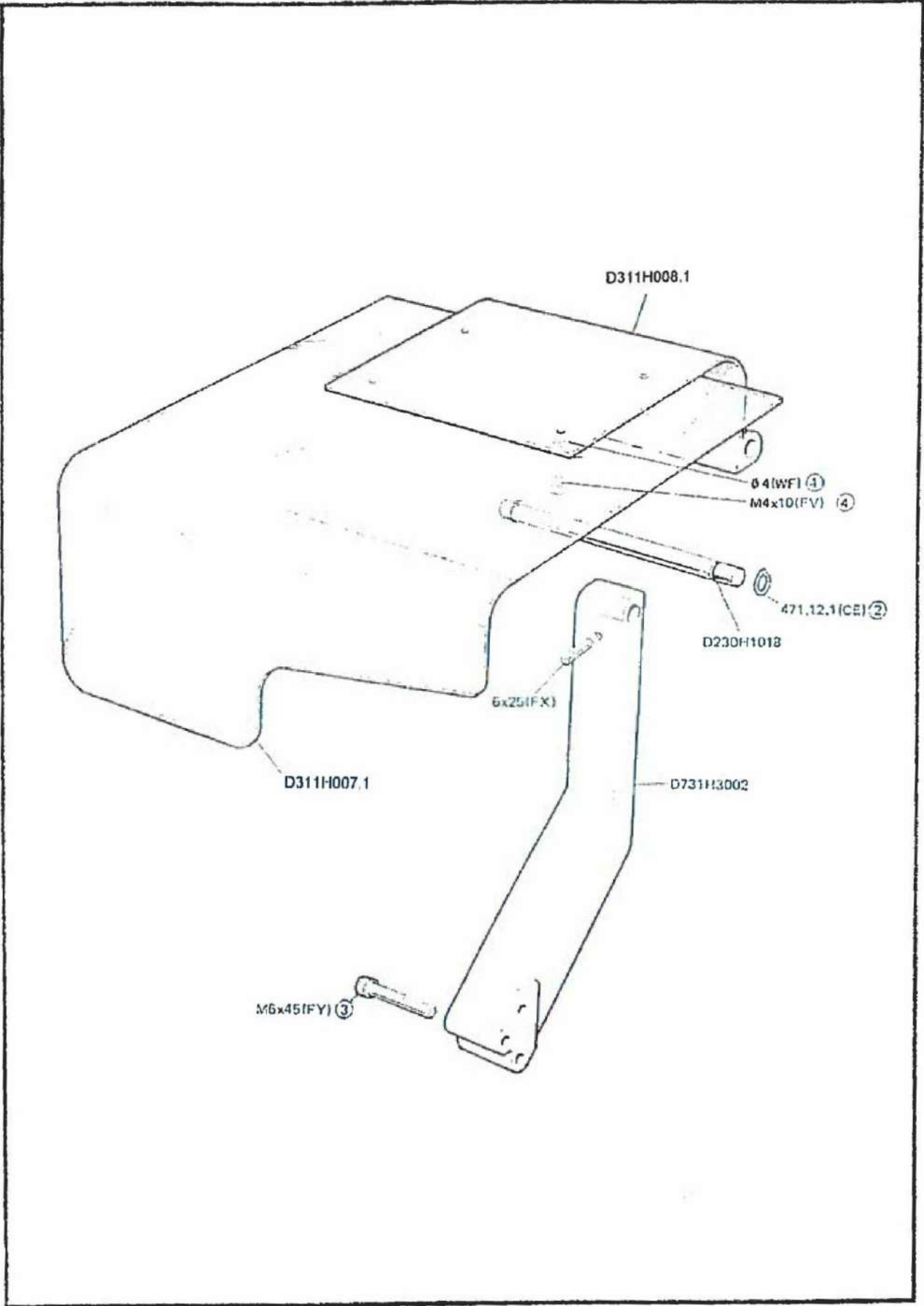

COOLANT PUMP, TANK AND FITTINGS

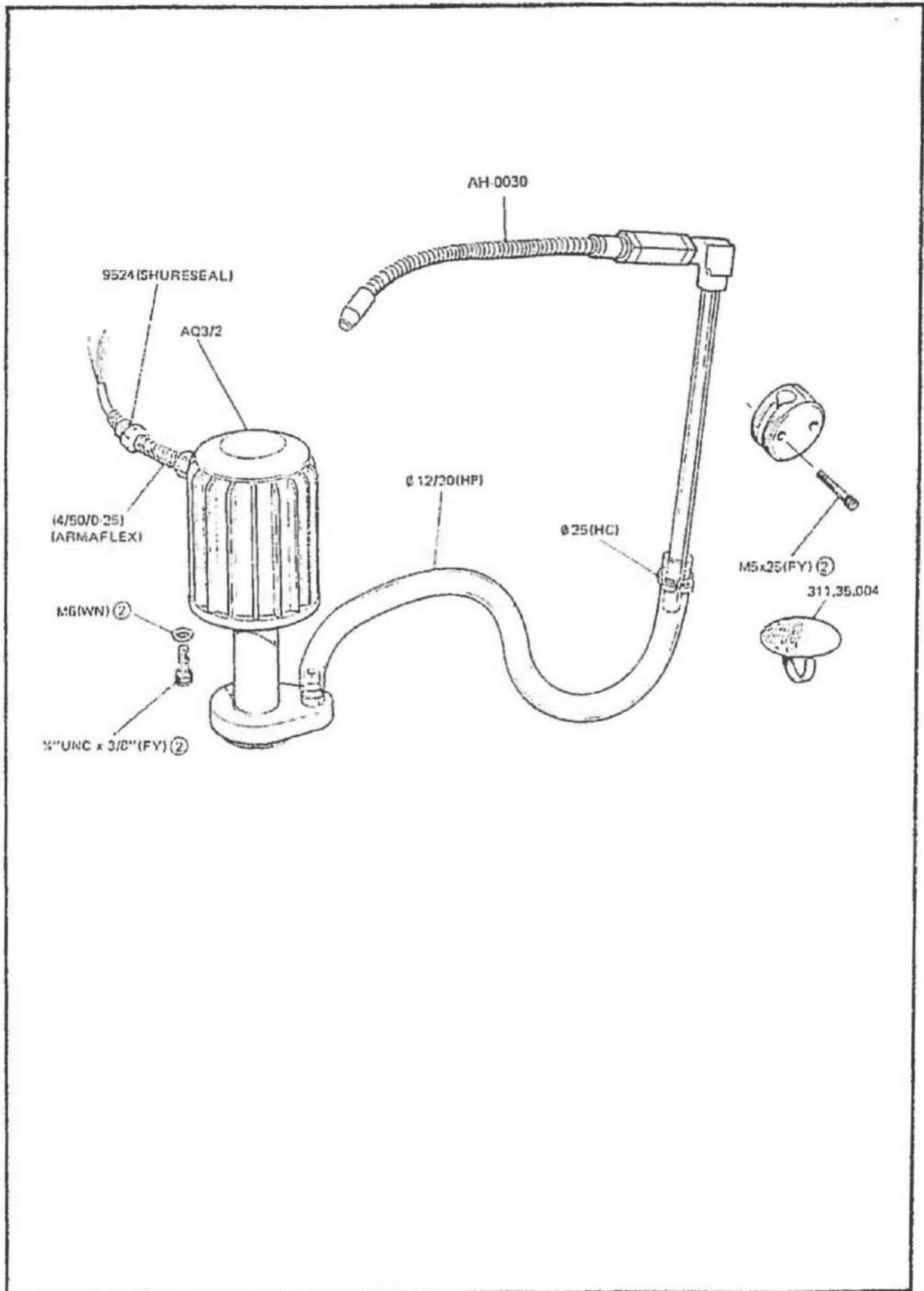

LOW VOLTAGE MACHINE LIGHTING

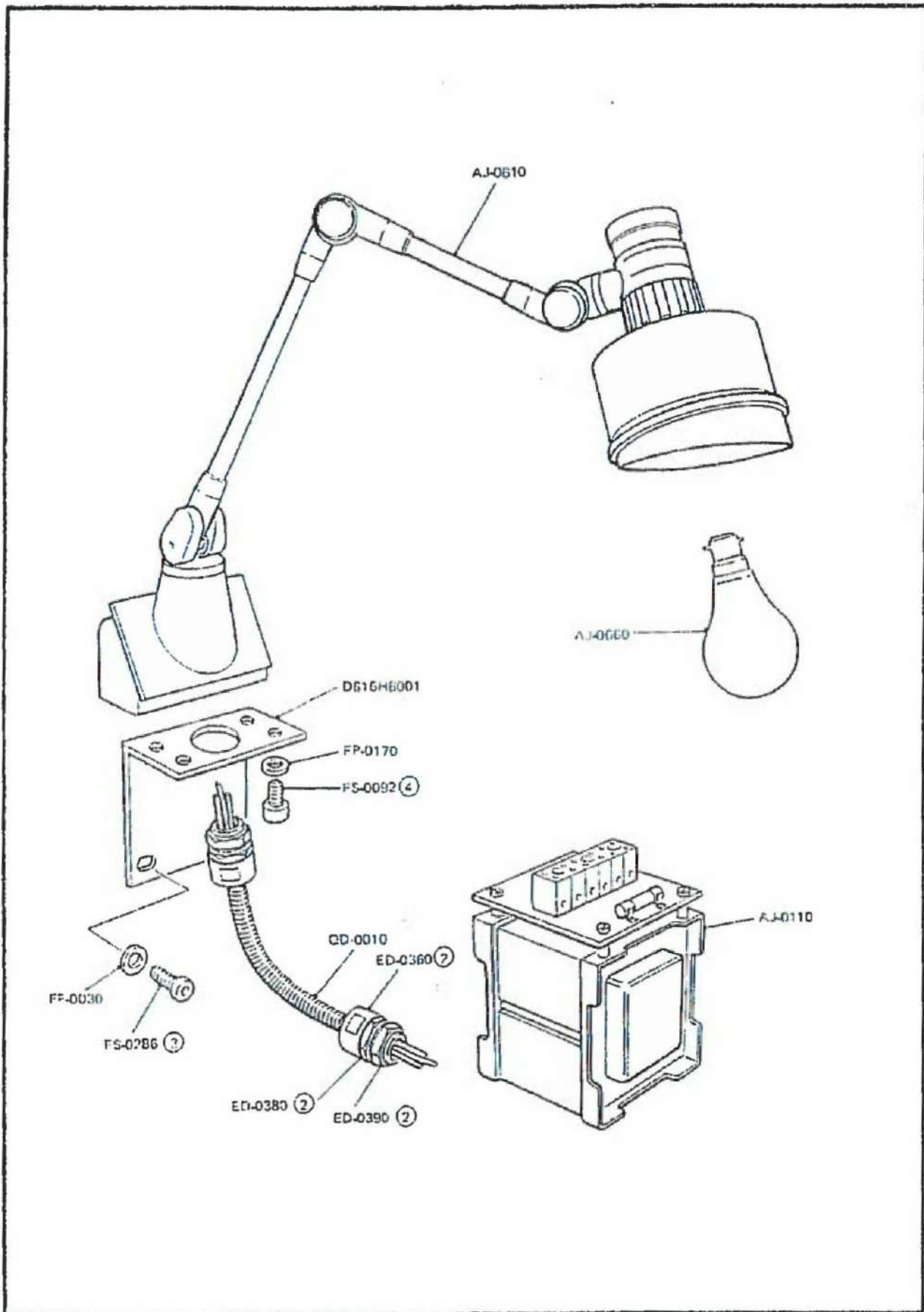

TRAVELLING STEADY

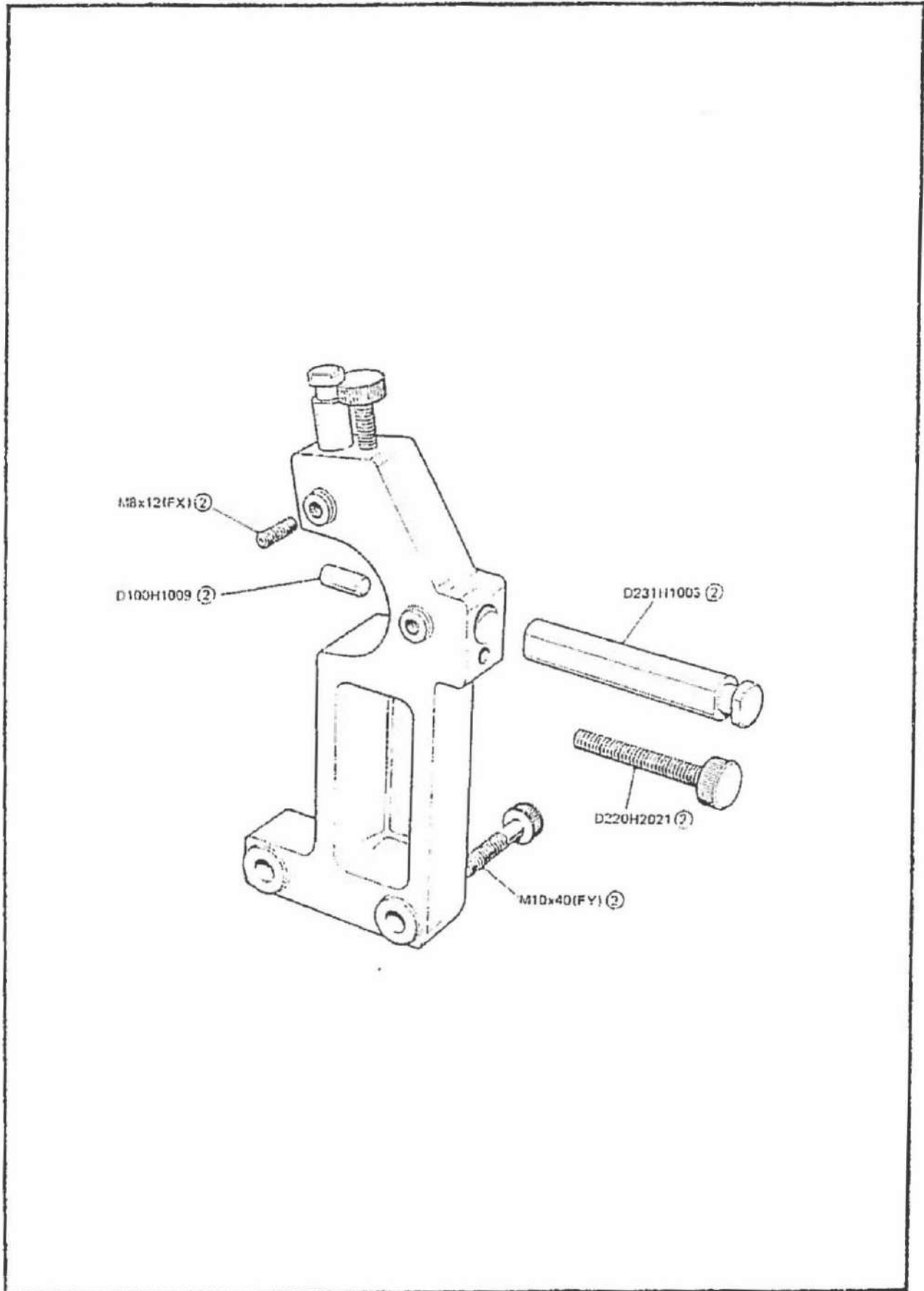

STATIONARY STEADY

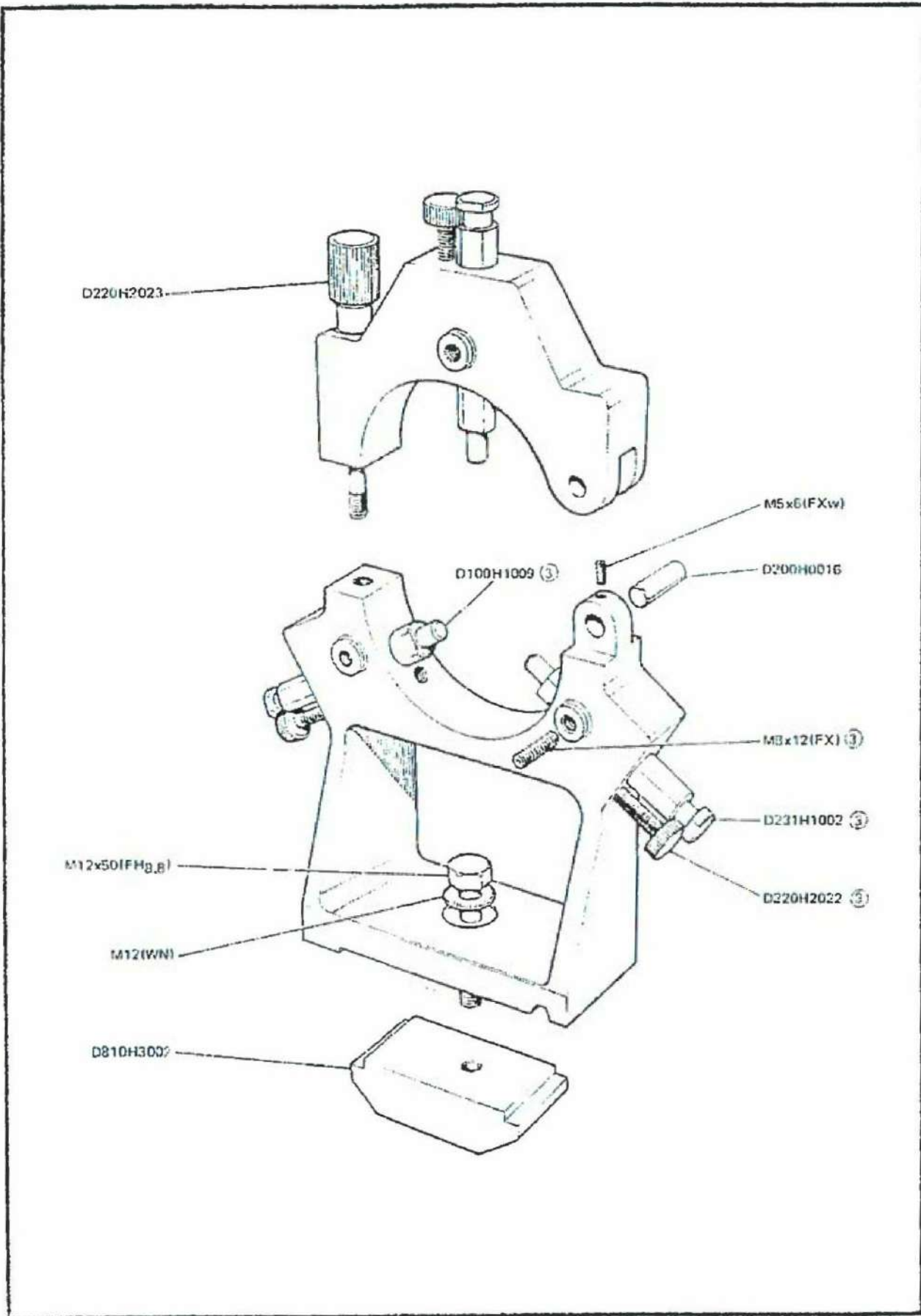

BED STOPS

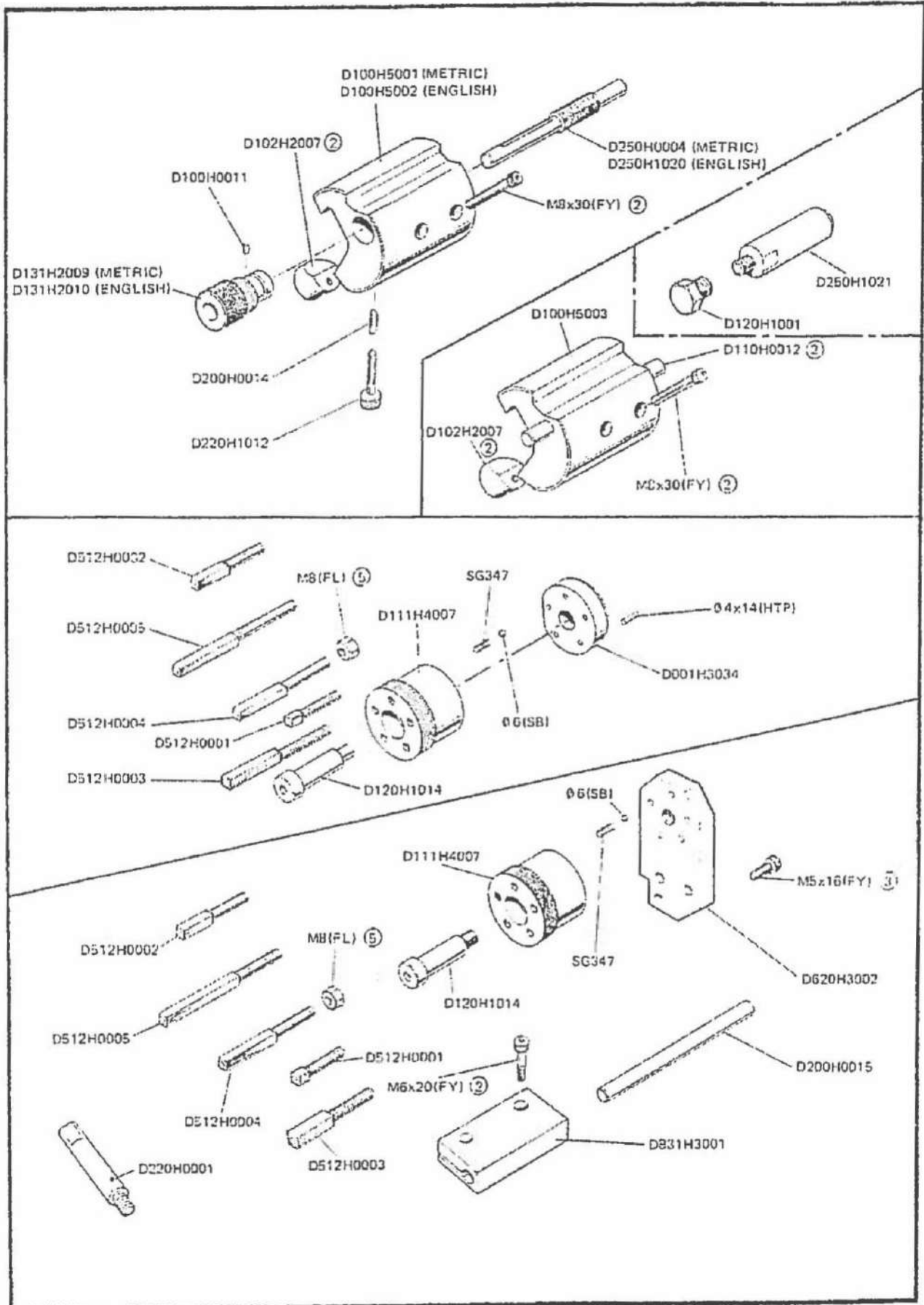

APRON DIALS

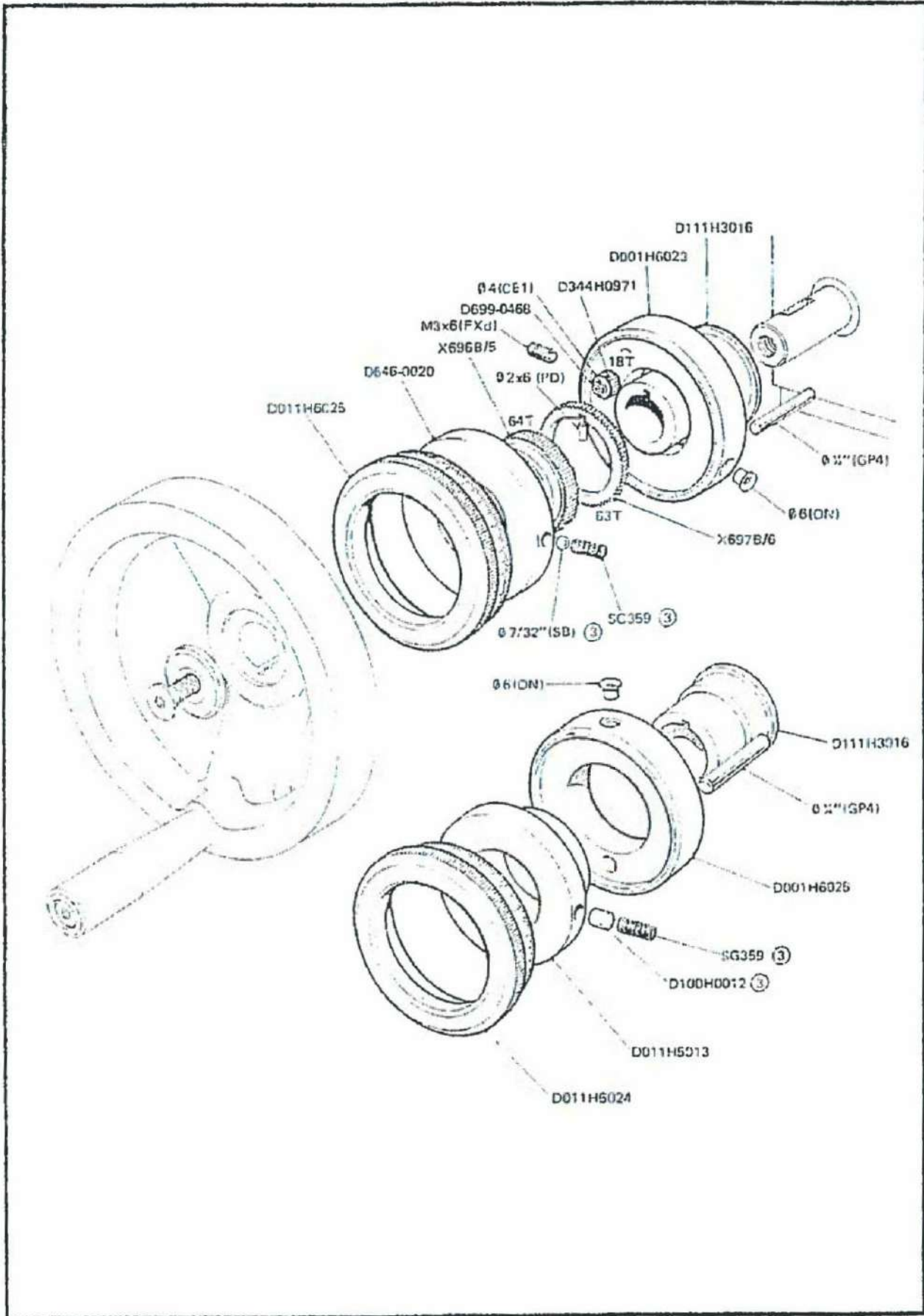

ELECTRICAL SECTION

M300 / STUDENT ELECTRICAL COMPONENT IDENTIFICATION

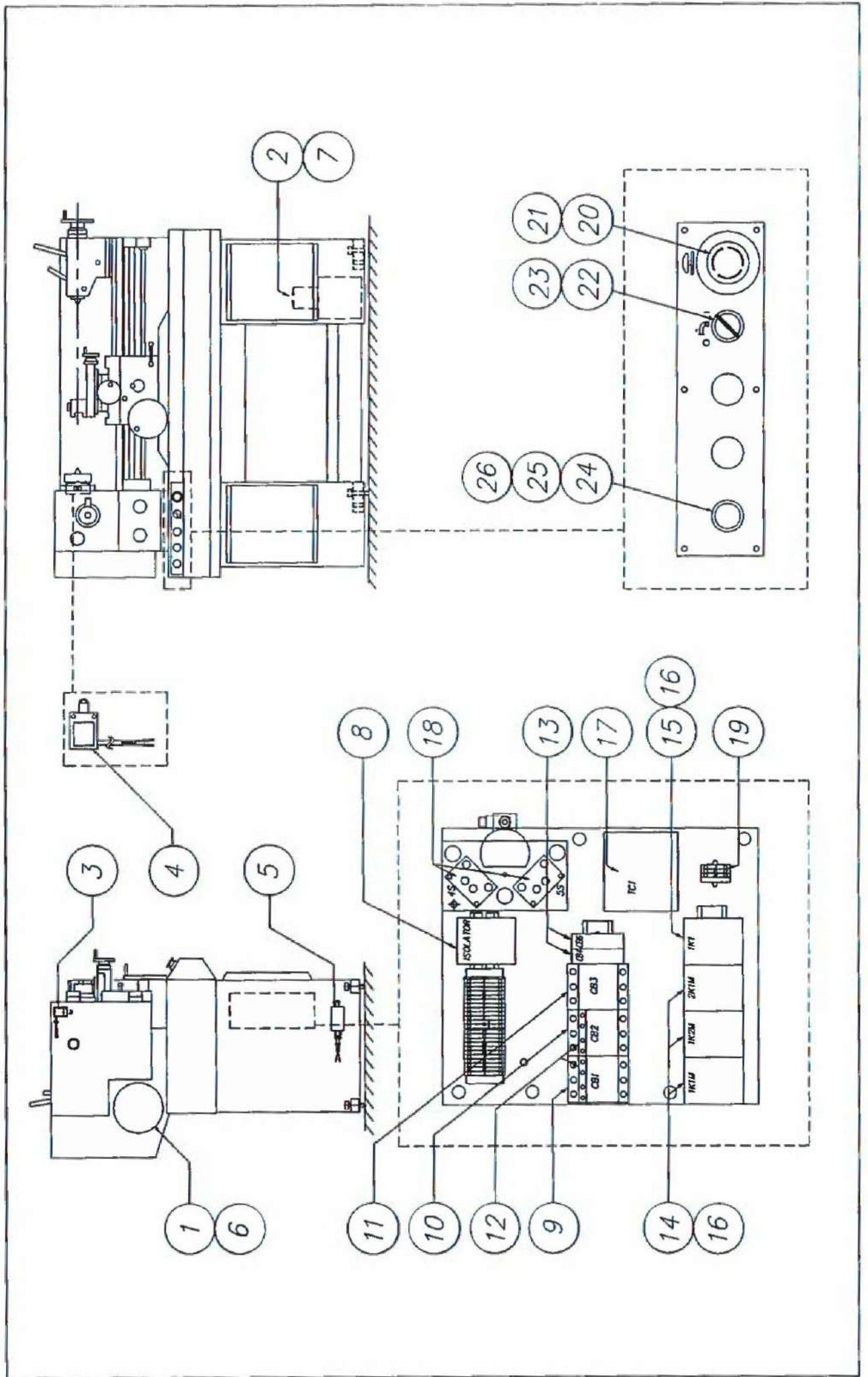

STUDENT / M300 ELECTRICAL COMPONENTS

ITEM No.	SCHEMATIC REF.	PART No.	DESCRIPTION	QTY.
LIMIT SWITCHES AND MOTORS				
1	1M	B618-0098	SPINDLE MOTOR 2.2Kw, 1500RPM	1
2	2M	B474-0039	COOLANT PUMP AND MOTOR	1
3	2S	A828-1739A	PULLEY GUARD INTERLOCK SWITCH	1
4	8S	A828-1850A	CHUCK GUARD INTERLOCK SWITCH	1
5	1S	A828-1851A	KICK BAR STOP SWITCH	1
6	U1,V1,W1	A828-1738A	SPINDLE MOTOR HARNESS	1
7	U2,V2,W2	A828-1536A	COOLANT PUMP MOTOR HARNESS	1
MAGNETICS PANEL ASSEMBLY				
8	QS1	E014-0078	MAIN DISCONNECT SWITCH	1
9	CB1	E012-0010	SPINDLE MOTOR CIRCUIT BREAKER	1
10	CB2	E012-0004	COOLANT PUMP CIRCUIT BREAKER	1
11	CB3	E012-0006	TRANS. PRIMARY CIRCUIT BREAKER	1
12	CB1/2	E011-0017	AUXILIARY CONTACT BLOCK	2
13	CB4/6	E013-0018	CONTROL AND OPTION CIRCUIT BREAKERS	2
14	1K1M, 1K2M, 2K1M	E011-0053	MOTOR CONTACTORS	3
15	1K1	E017-0017	NO-VOLT RELAY	1
16	1K1M, 1K2M, 2K1M, 1K1	E014-0007	CONTACTOR COIL SUPPRESSOR	4
17	TC1	E061-0090	CONTROL AND OPTION TRANSFORMER	1
18	4S, 5S	E031-0070	FORWARD/REVERSE SWITCHES	2
19	XS1	E074-0733	OPTION TERMINAL BLOCK	1
OPERATOR PANEL ASSEMBLY				
20	3S	E016-0112	RED MUSHROOM P/BUTTON - ESTOP	1
21	3S	E011-0118	SWITCH BODY WITH 1 N/C CONTACT	1
22	6S	E041-0047	2 POSITION SELECTOR SWITCH - COOLANT	1
23	6S	E011-0119	SWITCH BODY WITH 1 N/O CONTACT	1
24	1H	E021-0089	SUPPLY ON PILOT LIGHT	1
25	1H	E021-0090	SUPPLY ON HOUSING	1
26	1H	E021-0003	SUPPLY ON BULB	1

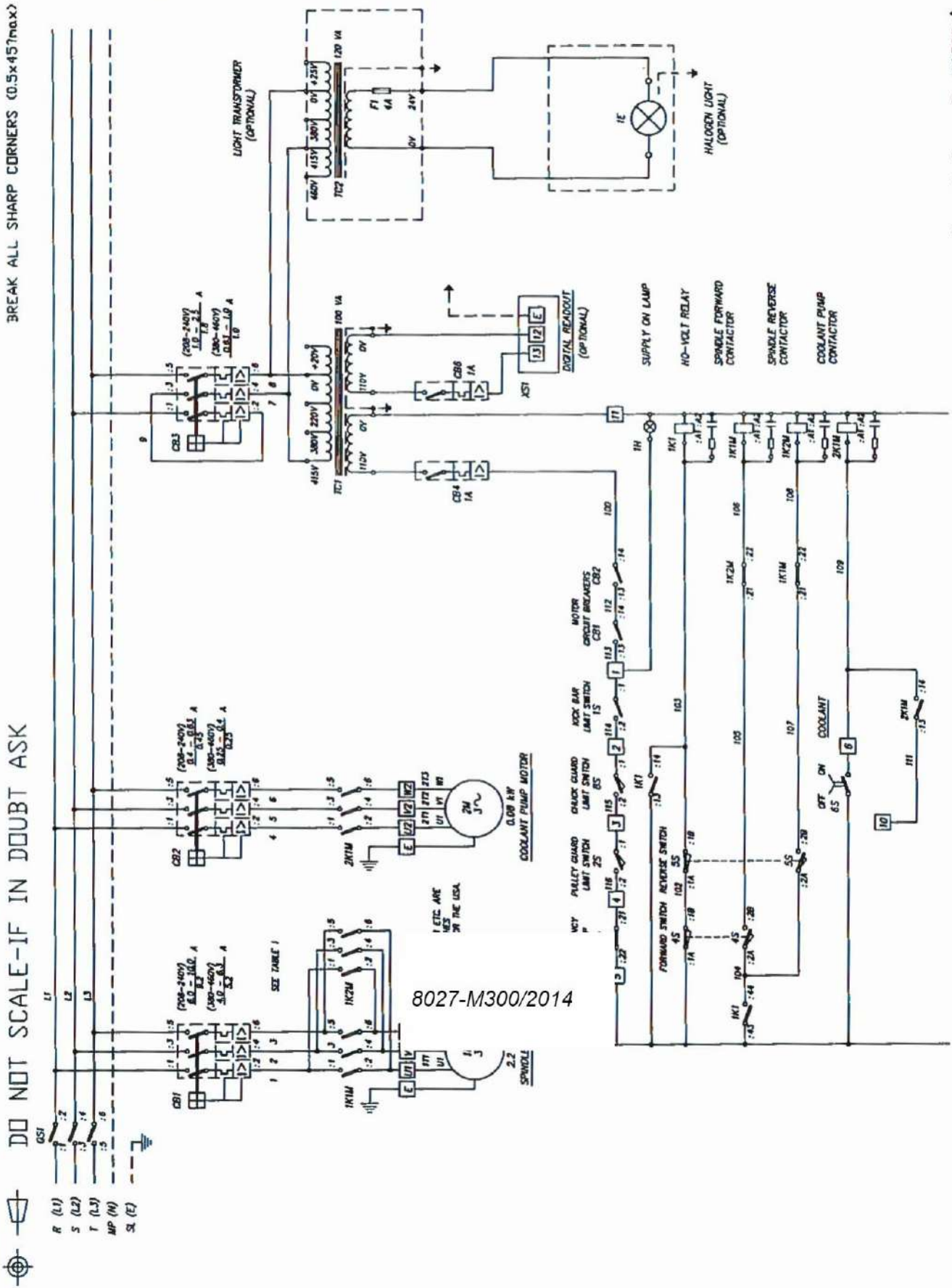

BREAK ALL SHARP CORNERS (0.5x45°max)

DO NOT SCALE-IF IN DOUBT ASK

8027-M300/2014

Generally Drawn To BS308Δ

ALL DIMENSIONS IN MILLIMETERS

This drawing is confidential and reproduction or communication of its contents in whole or part is prohibited without written authority of 600 Lathes Ltd.

600 LATHES LIMITED Beckmondwike, Yorkshire, England.

30J-050-001

30J-050-001

Part No.	Modification	Rev	By
30J-050-001			
Drawn	M HILL	Scale	01.03.13
Checked			
Approved			
Material			
Quantity			
Drawing No.	CIRCUIT DIAGRAM FOR M300 AND 600 STUDENT LATHES		

NOTES

Customer Service, Parts and Sales, call 800-575-2843

info@harrisonlathe.com



www.harrisonlathe.com